

CHAIRISH-

The chair which cares

-Deepak Baxla-

MD17MDES11007

Thesis Submitted to

Indian Institute of Technology Hyderabad

In Partial Fulfillment of the Requirements for

The Degree of Master of Design



भारतीय प्रौद्योगिकी संस्थान हैदराबाद
Indian Institute of Technology Hyderabad

Guide

-Dr. Prasad Onkar-

Department of Design

June 2019

June 2019

Declaration

I declare that this written report represents my thoughts and ideas in my own words, and where others' ideas or words have been included, I have adequately cited and referenced the sources. I also declare that I have adhered to all principles of academic honesty and integrity and have not misrepresented or fabricated or falsified any idea/data/fact/source in my submission. I understand that violation of any of the above will be a cause for disciplinary action by the Institute and can also evoke a penal reaction from the sources that have thus not been properly cited, or from whom proper permission has not been taken when needed.

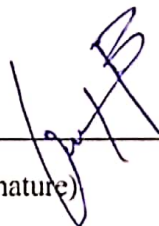
 12/07/2019

(Signature)

(- Deepak Baxla -)

(md17mdes11007)

Approval Sheet

This thesis entitled – Chairish – by Deepak Baxla – is approved for the degree of Master of Design.

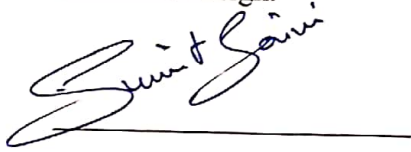

-Name and affiliation-

Examiner Sumit Saini

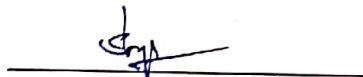

-Name and affiliation-

Examiner SHIVA JI

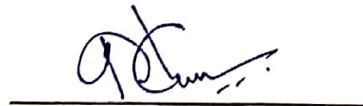

-Name and affiliation-

Adviser Dr. Prasad Omkar

-Name and affiliation-

Co-Adviser

-Name and affiliation-

Chairman

DATE : 12 July 2019
PLACE : Hyderabad

Acknowledgments

During the writing of this thesis, I got a lot of support. I would like first to thank my supervisor, Dr. Prasad Omkar, whose expertise was especially priceless in the creation of research topics and methodology. I want to thank my colleagues from Batch, Ph.D., and Juniors of their friends 2017-2019 in particular as Saroj Boipoi, Vivek Bhai, Jagdish Bhai, you people helped me when I was in need. I would particularly like to single out Beable Health who inspired me to work on such a relevant topic and (Sahara clinic for stroke rehabilitation) physiotherapist Dr. Shankar and Pratima for their support in research and giving us valuable guidance. Thank you, Hemlata Rawat, for the help you provided. Maneesha S, I want to thank you for your cooperation with my research and further my Thesis at IIT Hyderabad. I would also like to thank the faculty members, Dr. Deepak John Mathew, Dr. Neelkantan PK, Delwyn Remedios, Shiva Ji, Seema Kumar, for their guidance, you showed me the proper path and provided me proper tools to achieve what is needed for my thesis. Special thanks to our Director IITH U B Desai for being a silent supporter. Apart from this, thanks to my parents for their support. You are always there for me. In the end, there are my friends, who help a lot in our problems and findings, as well as provide a great distraction to relax my mind beyond my research.

Thank you very much.

Aim

A way to aid Stroke Rehabilitation

by using a cheaper and portable device for Stroke affected patients

so that the rehabilitation process can be made more effective and affordable to everyone.

Contents

Declaration.....	ii
Approval Sheet.....	iii
Acknowledgements.....	iv
Introduction.....	7
Chapter 1	9
1. stroke	9
1.1. stroke types	10
1.2. Symptoms of stroke	14
1.3. Stroke statistics	16
1.4. Cause and risk factors	16
1.5. Identifying stroke	17
1.6. Reducing risk factors and preventing complications	18
1.7. Process of rehabilitation	22
Chapter 2	27
Process of ideation and concept generation	27
2.1. Why lower limb?	27
2.1.1. Poverty and stroke	29
2.1.2. Products available in the market	30
2.1.3. Prescribed exercises for rehabilitation by physiotherapist	32
2.1.4. Need for exercise in immobility	34
Chapter 3	35
3. Chairish concept	35
3.1. concept 1	37
3.1.1. design and function	40
3.2. concept 2	43
3.2.1. design and function	44
3.3. concept 3	45
3.3.1. design and function	47
3.4. concept 4	48
3.4.1. design and function	48
Chapter 4	48
4.1. material	48
4.2. tools	49
4.3. guidelines for chair	53
4.4. prototype	57
References	66

Introduction

Chairish, the name came with the combination of two words 'chair' and 'cherish' as the project deals with rehabilitating stroke patients through a frugal and portable device where. Chairish aims to develop a tool for a stroke affected patients for their rehabilitation process, which includes the primary stage, secondary stage, and tertiary stage. Which could be available to all sectors of the Indian population as the rehabilitation process could be very expensive for many of the Indian community. Stroke is a main source of disability around the globe (6) many of the Indian people are deprived of the rehabilitation process as they cannot afford the therapy and the fee of the physiotherapist which is quite expensive for many of them. The machines and devices available in the markets and hospitals are costly and the regular charges for the therapy goes till 500 per day which is still quite expensive for many of the Indian population, and to deal with this problem we are coming up with a device which can be used by every stroke-affected patients of the country.

The primary stage of the stroke could be different in ischemic stroke and hemorrhagic stroke (stroke1.1 a & b) primary stage deals with the neutral postures of the body. Chairish, in this stage, will deal with keeping the body postures in their neutral position while sitting. This process is called 'total assistance' where the patient needs

proper assistance of the physiotherapist or family member or caretaker for the movement of their body from one place to another.

The secondary stage of stroke deals with the movement of the lower limbs through exercise on the device with the assistance of a physiotherapist or with any caretaker. Patients were made to do some first and natural movement of the joints of the lower limb. They come under partial assistance where the patient can do some change of joints and can do some exercise on their own but is unable to go from one place to another without some assistance.

The tertiary stage of stroke deals with the movement of the lower limbs through exercise on the device without any assistance of the physiotherapist or caretaker. This process is called resistance, where the patient can do the body movement and practices and can move from one place to another.

Chapter 1

1. Stroke

Stroke is a high predominance among grown-ups and the old, and one of the main sources of mortality on the planet is neurological disorder. The World Health Organization (WHO) defined stroke as a blockage in the blood supply to the brain, usually when blood vessel rupture or when a clot blocks the blood supply to the brain. (17) According to the WHO, Stroke is among the top leading causes of death worldwide and is a noteworthy reason for death and paralysis. (16)

Stroke is the leading global cause of disability. [9] Types of stroke; Ischemic and hemorrhagic. Most common ischemic [9]. Seventeen million people suffer from stroke annually, of which five million are permanently disabled [9]. After twelve months of stroke, 35% of patients who performed with lower bleeding still have the less functional capacity [10], which is associated with high levels of anxiety and reduced quality of life [11].

1.1 Types of stroke

a. Ischemic stroke

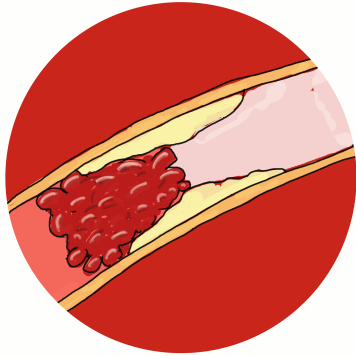

- Ischemic stroke occurs when a vessel supplying the blood to the brain is interrupted. It has about 87 percent all strokes (18)

- Ischemic stroke occurs when a clot or mass blocks the blood vessel; It stops blood flow to the brain cells. The underlying

position for this kind of obstruction is the development of fatty deposits depositing lining the walls of the vessel. This condition is called Atherosclerosis. (18)

- Two types: Thrombotic and Embolic

i) In an Embolic stroke, the body (usually the heart) creates a blood clot or plaque fragment somewhere and travels to the brain. Once in the brain, the clot travels through the blood vessel towards the brain to block the way. The lump is recorded there, blocking the blood vessel and causing a stroke. About 15% of people with atrial fibrillation are Embolicular strokes. The medical term for this type of blood clot is the embolus. (4)

ii) A Thrombotic stroke is caused by a blood clot traveling inside the veins that providing blood in the brain. This sort of stroke is typically found in individuals

having atherosclerosis and cholesterol. Medical terminologies for clots that are made on blood vessel deposits are thrombus. (4)

- Two types of clots can cause Thrombotic stroke: large vessel Thrombosis and small vessel disease.

i) A Large Vessel Thrombosis

- The most common form of Thrombotic stroke (the most significant vessel thrombosis) occurs in the major arteries of the brain. In most cases, it is due to prolonged atherosclerosis, in which rapid blood clots are formed. High cholesterol is a common risk factor for such type of stroke. (4)

ii) A Small Vessel Disease

- Another form of thrombotic stroke occurs when blood flow is blocked in a very small arterial duct (small vessel disease or lunar myocardial infarction). Very little is known about the causes of such stroke, but it is linked to highness (4)

b. Transient Ischemic Attack (TIA) or mini-Stroke

When blood flow to the part of the brain stops for a short period, also called 'transient ischemic attack' (TIA), it can mimic symptoms such as stroke. These symptoms appear and are less than 24 hours before the disappearance. While TIA usually does not cause permanent brain damage, they are a serious warning sign that a stroke may occur in the future, which should always be kept in mind. (4)



- A ‘transient ischemic attack’ is known as TIA or slightly stroke, and one stroke has almost the same side effect. (4)
- 40 The percentage of those who have TIA will be a real shock. About all strokes, a TIA occurs inside the first pair of days (4)

Hemorrhagic strokes are not common, out of 100, just 15 percent of strokes are hemorrhagic, which are responsible for around 40 percent of all death occurring out of stroke. A Hemorrhagic stroke is either a brain aneurysm burst or a weak blood vessel leak. Blood spreads in or around the brain, and creates swelling and pressure, damages the cells and tissues in the brain. There are two types of hemorrhagic strokes called an Intracerebral and Subarachnoid. (4)

- Intracerebral

The most common hemorrhagic stroke occurs when a blood vessel bursts inside the brain and blood leaks in the surrounding brain tissue (intracerebral hemorrhage). Hemorrhagic cells when dies out of bleeding the area affected by the bleeding stops working properly in the brain. High blood pressure and aged blood vessels are the most common causes of this type of stroke.

Occasionally an intracerebral hemorrhagic stroke may be due to the cause of aneurysm deformity (AVM). AVM is a genetic condition of an abnormal connection between the arteries and veins and is mostly in the brain or spine. If AVM is in the brain, the vessels may break, and the brain may have bleeding. The cause of AVM is unclear, but once diagnosed, it can be successfully treated. (4)

- Subarachnoid

In this type of stroke, there is bleeding in the area between the brain and the tissue that covers the brain, which is known as the subarachnoid space. This type of stroke is most often caused by a burst of an aneurysm.

(4) Other causes include:

- AVM
- bleeding disorders
- head injury
- blood thinners avm

1.2. Symptoms of stroke



face drooping



arm weakness



speech problem



time to call
emergency

The symptoms of strokes can be identified easily

Use the letters in "F.A.S.T." to spot a stroke

F - Face Drooping

if the face of any person is drooping on one side or is facing problem in smiling or chewing

A-Arm Weakness

if the person is feeling weakness in one arm or unable to lift the arm properly.

S- Speech

If the person is finding difficulty in speaking and unable to speak simple sentences, the hesitancy of speech

T- Time to take action

If all the above symptoms are there in any person, it is time to take immediate action.

(4) There are different medicines available which dissolve the clot when injected but

within a particular time given and there is a treatment available in which the clot can be sucked out through a pipe, but that also has to be done with a particular time limit
(3)

The best way to prevent stroke is:

To live a healthy lifestyle, control blood sugar and cholesterol, control your blood pressure,

A healthy diet is low in sodium and rich in potassium. A healthy lifestyle, avoiding smoking, low body mass index, moderate alcohol consumption, regular exercise, and a healthy diet, is associated with a deficiency in ischemic stroke. (3)

1.3. Stroke Statistics:

It is estimated that 4.5 million deaths occur in stroke in the world in one year, and more than 9 million strokes are left. Approximately one out of five women over the age of 45 and about 45 in four men may be expected to stroke if they live in their 85th year. The overall incidence rate of stroke is approximately 2-2.5 per thousand population. The risk of recurrence for more than five years is 15-40%. It is estimated that in comparison with 1983 by 2023, the number of patients experiencing the first stroke of about 30% will be sufficiently increased. There is a total prevalent rate of about 5 per thousand population. After one year of stroke, 65% of the surviving people are functionally independent, is the leading cause of adult disability in stroke

(2)

1.4. Stroke causes/Risk factors:

Healthy diet

A healthy diet helps in improving your general wellbeing and can enable you to reach or keep up a stable weight. Proper dieting includes settling on educated choices about sustenance decisions and adjusting your calories. (4) 2015-2020 Dietary Guidelines:

Healthier eating habits include:

- Green vegetables
- Fruits
- Cereals, of which at least half are whole grains
- Fat-free or low-fat dairy with milk, curd, cheese, and fortified soya drinks
- protein foods, seafood, meats, and eggs, (beans and peas), and nuts, and soya products
- oil

Extra weight puts weight on the whole correspondence framework. With this, individuals might be bound to have elevated cholesterol, hypertension, and diabetes; they can expand the danger of stroke.

Physical activity

Exercising for more than five times per week reduce the risk of stroke. standard 10 to 30 minutes of exercise per day could be beneficial to avoid stroke it can be done by simple means a walk or any simple sports activity like cycling or jogging etc.

Tobacco smoking

The danger of stroke is multiplied contrasted with smoking. Smoking expands clot arrangement; the blood turns out to be thick and builds the measure of plaque development in the arteries. it is hard to quit smoking but never give up.

Alcohol

Drinking a lot build the danger of high blood pressure and stroke. The motivation behind drinking with some restraint - for men not to drink two beverages per day and one day drink for ladies.

1.5. Identifying stroke:

FAST and BEFAST are easy steps to recognize a stroke.

FAST: Face drooping, weak arms, speech detection, time (necessary action on time).

BEFAST: Balance problem, Eyes sight, Face droop, Arm Weakness, Speech Difficulties, Time

1.6. Reducing risk factors and preventing complications

A high need for stroke rehabilitation is diminishing the danger of stroke hazard, (for example, treatment and the executives of comorbidity as hypertension). An injury keeps the unfortunate casualty at a high danger of recurrence; Therefore, cautious management of hazard elements is essential. (20)

Another significant need is the anticipation and treatment of secondary complications, which is typically connected with the stroke. The secondary complication can have adverse effect persistent restoration. (19) These include:

- Spasticity. **The mobility of a patient might be constrained. Numerous restorative interventions can support: Stretching, Splinting and Asanas and Movement.** [21] Oral operators, for example, botulinum and clonazepam and parenteral treatment, for example, botulinum poison are infused into the affected muscle. [22] Poorly managed spasm not only reduces functional independence, but is the result of painful contraction potential, through which cleanliness, especially in contracted hands, is a challenge.
- pain (central and nociceptive). pain in the shoulders of the stroke is normal. Physiotherapists are regularly ready to help with a lashing, back rub, or in active development. Therapeutic management might be required.

- Pressure ulcers. Stroke patients, mainly responsible for their reduced mobility, are more at risk of developing ulcerative ulcers. Turning on the bed regularly, adequate nutrition and pressure care education is an effective deterrent strategy for patients and their families/caregivers (22). Should a pressure ulcer develop; a physician requires experienced nurses in an initial assessment and treatment and pressure ulcer management.
- Profound vein thrombosis and aspiratory embolism. The diminished versatility of a stroke patient puts them at high hazard for profound vein thrombosis and pneumonic embolism. Starting prophylactic management includes the utilization of low atomic weight heparin and pressure tights to guarantee opportune conclusion and right treatment to doctors and attendants; there is a should be careful about any side effects and indications identified with profound vein thrombosis or aspiratory embolism.
- urine and stool incontinence. Incontinence is a typical unpredictability of stroke. Utilizing an inhabiting catheter in the extraordinary management of a stroke persistent. fluid management avoids urinary maintenance and averting skin breakdown. Nonetheless, long haul use puts a patient in danger for the urinary disease. These frequently require anti-infection mediation, in which multi-safe life forms are regularly found. Because of contamination, a patient does not feel enough to participate in their recovery. Counterfeit incontinence is a less regular long-haul issue since it is frequently settled inside the initial two weeks after a stroke. False Impression Syndrome, be that as it may, is general and preventive administration is fundamental.

- Desire pneumonia There is a danger of goal among patients with dispassion. Intercession by a discourse and language advisor helps in dealing with this hazard. Nonetheless, for the underlying treatment of any side effects, a doctor ought to have a low limit, and the goal indications of the yearning before the patient's goal pneumonia create. At the point when there is a doubt, patients ought to be encouraged with the nasogastric tube until it is completely cleaned for oral admission by discourse and language specialist.

2. Therapy-specific rehabilitation

therapeutic subjects generally recovery incorporate physiotherapy, word related treatment and discourse, and language prescription. The jobs of a physiotherapist and an expert specialist frequently cover. [23] Although both disciplines mainly work with motor loss of stroke patients but focus on their attitude and various disorders. Physiotherapist focuses on the proper condition of Hematinic patients as well as the initial mobility and mobility of patients, while a business practitioner works towards resuming the activities of daily life (such as beauty and dressing), often Includes the use of the device. Proficient advisors are likewise associated with the underlying subjective test, and intellectual recovery is done related to discourse and language specialist. Come back to-work appraisal and driving assessment is normally the area of the word related specialist. Many stroke patients are experiencing subjective, transferable, and gulping misfortunes. Discourse and language counselors are exceedingly arranged to regulate and treat such imperfections.

3. Patient and family/parental figure training and consideration

Altogether, patients and their families/parental figures are at first seen as a part of the interdisciplinary gathering. They ought to get instruction on the causes and outcomes of the stroke. There ought to be persistent cooperation between the interdisciplinary group and patients and their families/guardians about recovery objectives and advancement.

4. Psychological/psychiatric support

There are various sorts of neuro continuations after stroke - the most well-known burdensome indications are. Post-stroke depression creates somewhere in the range of 25 and 75% of patients. In any case, it isn't extraordinary for individuals with a stroke to encounter the length of feeling. Dread, tension, sentiments of pity for your physical misfortune/change, just as different side effects like those found in discouragement may show up.

These regularly spread after some time and can be satisfactorily do with help from the interdisciplinary group, including advisors. In this manner, it is imperative to incorporate a therapist or expert in the group. On the off chance that the above indications stay with other patient medications and meddle, thinking about the comparability of gloom after the stroke, the restoration doctor ought to have a high list of doubt to analyze. Afterward, pharmacotherapy the board with specific serotonin redetect inhibitors or heterocyclic is normally warrants, and specialists may require referrals.

5. Sustenance and diet

Sustenance is a noteworthy post-stroke restoration intervention. A dietician should be a piece of a stroke patient's interdisciplinary gathering from the most punctual beginning stage of the recovery procedure. Unhealthiness is a typical issue, either because of trouble in gulping or because of issues in conveying. Thusly, the patient will in all probability be not able pass on their dietary needs satisfactorily. The restoration procedure is requesting, and a malnourished patient does not have the vitality or mental concentration to take an interest completely in all parts of its recovery.

1.7. Process of rehabilitation

a. Definition of rehabilitation

According to World health organization “(supporting) those with health conditions to stay as autonomous as could be expected under the circumstances, to take an interest in training, to be financially profitable, and satisfy significant life jobs.” (13)

- rehab is "a procedure of dynamic change by which an individual who has turned out to be impaired gets the learning and aptitudes required for an ideal physical, mental and social capacity" (14)
- recovery is "the degree to which body structures and capacity, just as exercises, come back to their pre-stroke state."

The procedure of rehab includes settling and updating recuperation procedures, and driving mobilized individuals, living autonomously in the network. Shockingly ones have returned to the course of action of free-living; there is no credibility of rehab, recuperation is connected to streamlining the individual fulfillment for those people who are encountering a stroke and decreasing the ceaseless thought inconvenience. Recovery from Stroke is a ceaseless procedure that can proceed for a considerable length of time or years, for the most part past the time of any formal restoration administration. Long haul recovery is basic for supporting individuals well after the stroke, decreasing difficulties, lessening the danger of repeating occasions, and diminishing the weight of consideration.

b. hyperacute or primary phase of rehab (0–24 hours after stroke)

Rehabilitation is required very soon in the hypertrophy stage - which causes individuals to get up and become dynamic inside 24 hours of a stroke. As indicated by rules in numerous nations on stroke restoration, they don't encourage to get out ahead of schedule from the exercises of bed, yet frequently little sessions outside the bed are connected to great states of good outcomes. (12)

c. acute phase of rehab (1–7 days after stroke)

Until the day after the stroke, except if medicinally contraindicated is done, individuals with stroke should begin movement bedding action and different mediations to advance and streamline their recuperation. By and large, this first week after the stroke happens when the wellbeing group is resolved. The subsequent stage

should appear as though they give it a second thought, and whether formal inpatient restoration is the most ideal path for that individual. For a few, this is the first run through in the principal seven day stretch of extraordinary consideration that they will have a hazard to the full interdisciplinary group, and it is significant that recovery necessities are broadly assessed as of now, and restoration mediation for explicit shortages will begin at the most punctual. (12)

e. early subacute phase (seven days to three months after stroke)

For those individuals with continuous rehabilitation needs, the scope of various models for recovery is conceivable. A 2012 Cochrane audit found that appropriately resourced and staffed Early Supported Discharge administrations, where patients are released home from the intense medical clinic and get in-home recovery administrations, prompted increasingly great results contrasted and ordinary administrations. Despite whether a restoration administration is conveyed in a medical clinic or the network, key components incorporate a properly talented multidisciplinary group that incorporates nursing (ideally with master recovery preparing), word related treatment, discourse and language treatment, physiotherapy, and social work. (12)

f. General principles

There is solid proof that task-specific preparing of practical undertakings improves an individual's capacity to play out that errand after stroke. Put, this implies rehearsing assignments that are troublesome, however much as could reasonably be expected and in whatever number shifted settings as would be prudent. They hold for retraining sitting equalization, moving from sitting to standing, standing parity, and strolling. Along these lines, tedious task-specific preparing is a center rule fundamental restoration after stroke. It is fundamental to consider the experience of recovery from both the patient and the family. Key points rising up out of two later abstract efficient reviews include: the prerequisite for staff to energize self-standard, control and motivation, the normal experience of patient exhaustion, frustration and shortcoming, and from the family's perspective, an aching to end up being even more viably connected with the recuperation system, and the ought to be kept instructed and checked out. (12)

g. Improving mobility (walking ability, transfers) and balance

Unequivocal modalities including circuit class treatment and treadmill planning with or without body weight support may be of explicit use. Increased reality getting ready for walking is a decently new thought and incorporates the use of advancement that reenacts and allows understanding relationship with real-world conditions. For walking setting up, this generally incorporates combining either a video screen or a

head-worn device that gives visual data while walking around a treadmill or staying on an evening out board. Progressing systematic reviews have uncovered advantages for this strategy when it is used to either supersede standard treatment or incorporate additional treatment time. It isn't evident whether the advantages of the treadmill and VR arranging are an immediate aftereffect of the impacts of expanding time rehearsing the display of strolling alone, or some regular common for the intervention itself. Where muscle deficiency purposes of containment work, and there is most likely some secured volitional improvement, quality getting ready after the benchmarks of dynamic over-weight may be useful and does not impact tone or spasticity. (12)

h. physical activity

Cardiorespiratory degrees of people with stroke are deficient, despite when they have been assessed inside a month and a half of stroke. This activity insinuates people with stroke are routinely working at the purposes of control of their high-sway capacity to perform standard activities of consistently living. Ordinary physiotherapy sessions, even those went for improving walking limit are missing to propel upgrades in cardiorespiratory wellbeing. As such, beginning express high-sway planning as in front of calendar as possible after stroke is endorsed. Given that deficient physical development is one of the most significant risk factors for stroke, people with stroke should in like manner be maintained to make part in ordinary physical move in the whole deal. General, express principles for exercise after stroke are open. (12)

Chapter 2

2. Process of Ideation and concepts generation

2.1 Why lower limb?

Lower limb function, crucial for posture, stance, and locomotion, experiences commonly better recovery than upper limb function (15). Lower limb motor deficits after stroke, when present, relate closely to morbidity and mortality due to the risk of falls, fractures, and venous thromboembolism related to immobility (6). Beable health is the inspiration for this project. Physiotherapist DR. Shankar and Pratima (Sahara clinic for stroke rehabilitation) During the visit at the clinic shed lights on the problems faced by the patients, interaction with the patients and their family members brought up many problems and issues related in the process of rehabilitation, where many gaps were found in the rehabilitation process.

some of the general problems which were discussed at the clinic were

- expensive process
- products and devices are costly
- products for lower limb rehabilitation are very few and costly
- Therapy per day for many of them are not affordable
- Patients wanted themselves to be independent and to walk on their own; this was the primary issue.

Based on the problems mentioned above, the decision was taken to work on the lower limb and to develop a device that will help in the rehabilitation process for the patients who cannot afford the expensive therapy and devices.

Many kinds of research are in process for stroke rehabilitation; designers and engineers have developed many products and services for stroke patients. They are instrumental in the rehabilitation process; still, during the further research on the stroke and the rehabilitation process, it was found that there are still many gaps and there is a vast scope to work. The initiative was taken to work on something which would be socially relevant and beneficial for the section of that society who are having a stroke.

The motivation and inspiration for the project were Habib Ali and Shree Hari, the founders of the Beable Health, who gave the initial guidance. DR. Prasad Onkar, guided throughout the timeline of the project regarding the technical and visual aspects, concept development, design aspects, product interface, user experience, etc. Having a background of Fine arts this was the first attempt towards the product development and product design.

2.1.1. poverty and stroke

Risk factors of stroke in the urban Indian population are similar to those of developed nations, and they can likely be quite different among people suffering from poverty. Apart from this, the options for treatment of stroke are less in developing countries like India. There is a lack of well-organized stroke services and emergency

transportation services, many treatments are ineffective, and many stroke sufferers can influence access to sociocultural factor medical care. Most stroke focuses are presently in the private sector, and to build up such focuses in the public segment, immense capital speculation will be required. Given the constrained assets accessible for emergency clinic treatments, it is sensible to stress compelling population-wide interventions to control or lessen the danger of significant stroke hazard factors. There is a need to make a concerted effort to ensure access to such stroke care programs which are in line with Indian communities and access to the large population, i.e., the poor. (24) Stroke, the second most common reason for death, caused 5.8 million. 40% of stroke passing happened in individuals for more than 70 years old. (25) Globally, there are approximately 15 million new acute stroke incidents every year, and approximately 55 million people have a stroke at some point in the past. Two-thirds of these individuals live in lower and middle-income countries like India. (26) By 2050, it is estimated that 80% of stroke incidents people living in these areas will occur.(27,28)

2.1.2. Products available in the market



The research on the available products in the market showed that there are very few products for lower limb rehabilitation that are available and all of them are so expensive that middle-income group people and lower-income group people cannot afford those therapy products if we say for Indian population.

source: Trunsan medical, Meet care, jhealth care

To deal with the problem and to fill the gap where the rehabilitation can become affordable for all the areas of the general public, the venture was started as a scholarly task.

2.1.3 Prescribed exercises for rehabilitation by the physiotherapist

source: Department of Physical Therapy the Ohio State University Medical center

1. Straighten each knee.

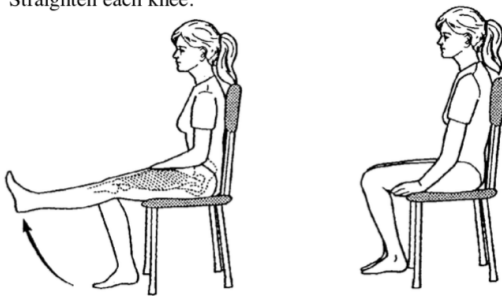

4. Leave your toes on the floor and lift your heel up and down.



2. Keep your knee bent and lift your leg up as high as possible. Lower it down slowly.

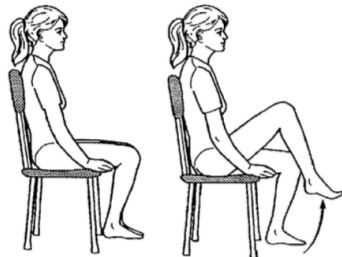

5. Alternate tapping your toes and lifting your heel.

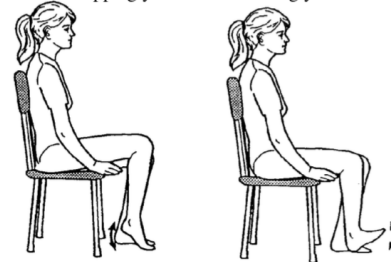

3. Leave your heel on the floor and tap your toes up and down.

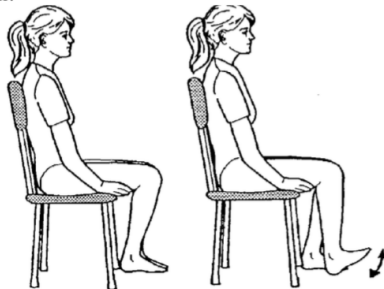

Some of the basic exercises that are suggested by the physiotherapist and are clinically proven were implemented on the device which includes:

- adduction/abduction of footrest

- Dorsiflexion/plantarflexion at footrest
- extension/flexion

The patient is immobile in this condition, and for doing these exercises they need some assistance, to deal with this situation the project here came up with a device that can at the same time help the patient to maintain their neutral body postures. On other help in doing the exercises, due to the condition of patients, the device was also designed so that the patient can even go in the supine and prone position in the initial ideation.

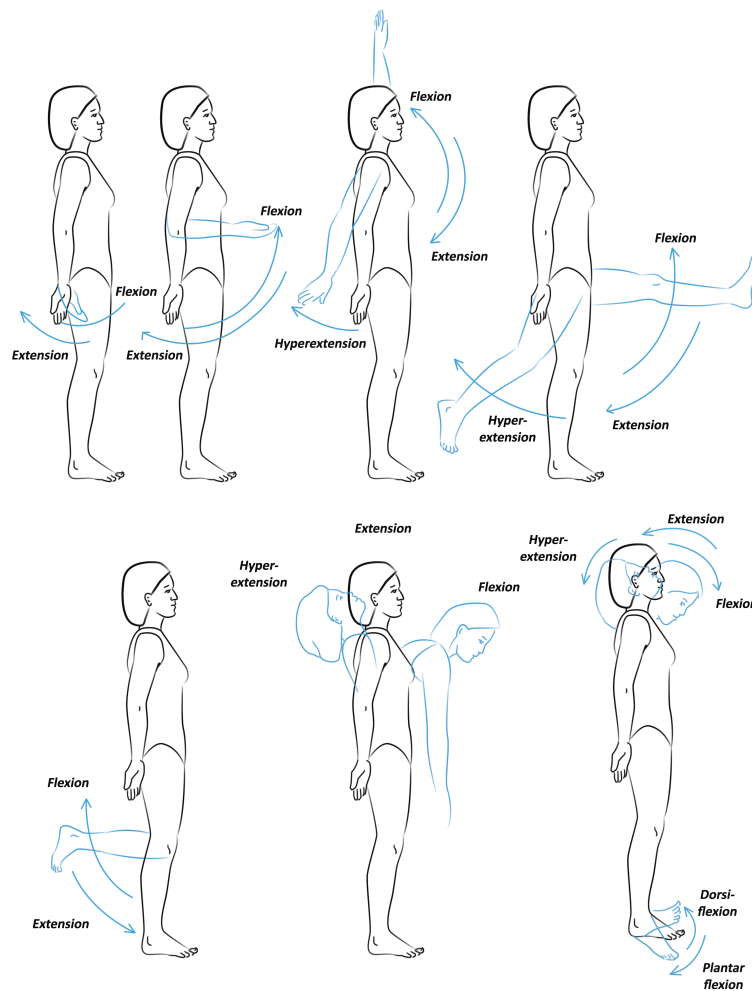

2.1.4 Need for exercise in immobility

Man's body is systematic for speed. Mobility, the means of skeletal muscle, makes up 40 percent of the body mass. Its structure and metabolic efficiency allow for a skilled and almost instantaneous complete comfort for a high level of activity. As a muscle becomes active, its blood flow can increase from 15 to 20 times the value of comfort, and the number of open capitals can increase 50 times.

The metabolic rate of muscle working on a muscle of comfort is probably 50 to 100 times more. Working muscles need to be supplied with nutrients and oxygen. We need to remove metabolic waste and carbon dioxide.

The ability to do accurate, coordinated movements is also adversely affected by inactivity for a long time. The pyramidal and extrapyramidal systems make it possible to gear the force of muscle compression to work in hand.

The activation of certain muscles and the restriction of others is the key to the precision coordination of motor activity. It allows for an immediate improvement of sensory deformity errors from muscles, tendons, and joints. Significant coordination of muscle activity is achieved without any input.

Our only motor system has to do a specific job, to walk through the room, to take a book, etc. should coordinate the necessary, which rests the contact of the muscles and the rest and the force of muscle contraction Does automated work. It happens at a sub-level.

When a person is stabilized for a while, the nervous system quickly and efficiently loses the ability to coordinate movements. A patient arriving from the bed for the first time after a long period of imprisonment will stumble about it. Their feet do not obey their commandments.

Of course, the muscles are weaker than the long-term use, but the ability to skillful movement is also reduced; It will take several days and months to complete this task.

(30)

Chapter 3

3. Chairish Concepts

3.1. Chairish Concept 1

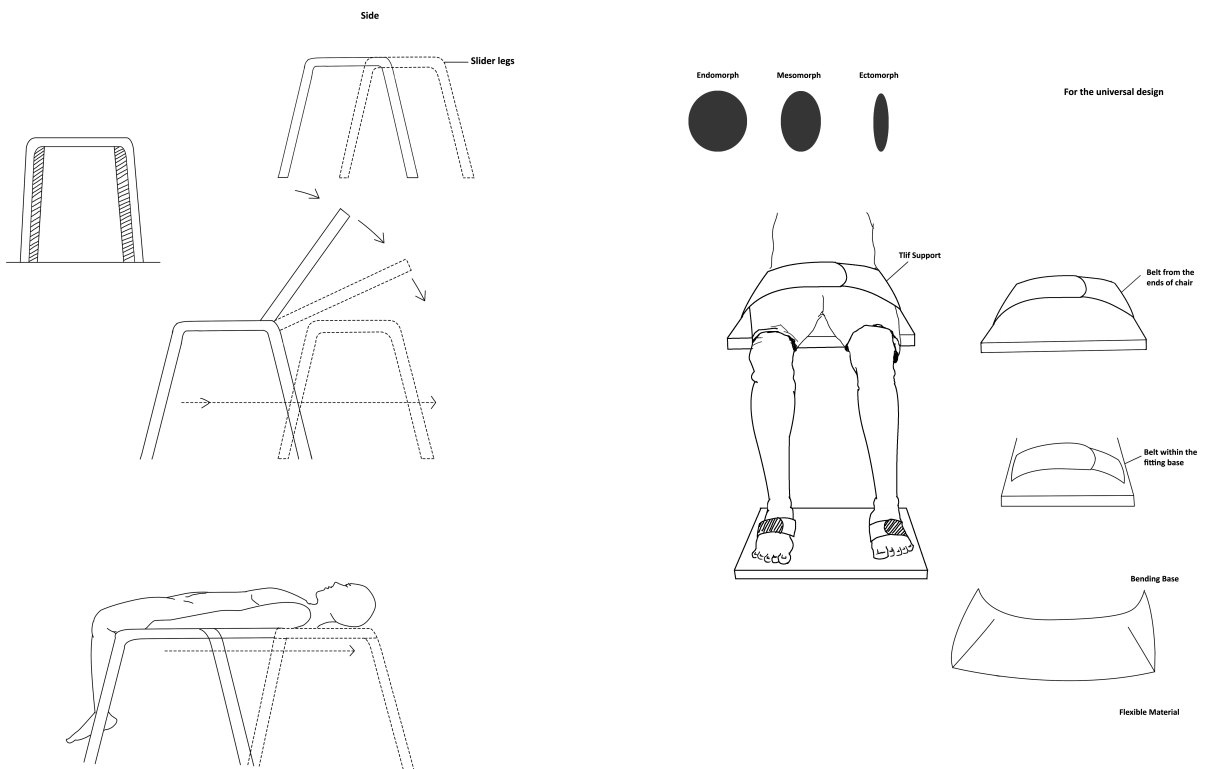

The initial concept and idea were to make a bed cum chair for the stroke patients for their motor recovery of the lower limb. Considering the secondary stage of the stroke where patients can do some movements by partial assistance of the physiotherapist or caregiver, this was based on the experience with the clinical visits and interaction with the patients and their family members and their needs.

The idea was if a patient becomes independent and mobile, he can be easily motivated to do upper limbs exercises and activities, lower limbed function, important for posture, attitude, and movement, comparison of upper organ function Usually experiences better recovery. If a person cannot do basic activities such as going to the toilet, it makes him depressed than any other activity.

In the first concept, the focus was basically on the bilateral exercise of the lower limb, and the device was given with different alterations according to the body postures of the patients. As stroke brings up the immobility to the patients, and it is very difficult for the caregiver to move them from one place to another. to deal with this problem the design of the device which is portable as well as can be used as a therapy device and even a bed was designed, so that the caretaker does not need to move the patient from one place to another for different activities.

The key highlights of the Chairish concept 1:

- Chair

- Inclined backrest and bed
- Belts at different levels to hold the body
- Swinging footrest
- adduction/abduction of footrest
- Dorsiflexion/plantarflexion at footrest

3.1.1. Design and functionality of the device

The device was designed for the stroke patients, who, due to a stroke, became immobile. For the people who are having a stroke needs exceptional care for every activity as they cannot do the simple daily activities, so for them, the device was designed in such a way that without moving anywhere they can do the exercise, eat and sleep. The device works on different dimension and orientation; the basic requirement of the device was to make the patient rest properly on it (seated position). The backrest can be adjusted to an inclined position to make the patient sit at comfortable postures and can lay down in total inclined backrest.

The secondary function was to keep the body of the patient steady through belts at different levels of the device as the body of patients tend to fall and droop who is suffering from a stroke. The lower part of the device is equipped with the exercise tool which is a swinging paddle/board on which patient can put their legs, and it tends

to move in the sagittal plane (extension/flexion, dorsiflexion/plantarflexion, adduction/abduction)

The purpose of keeping the swing is to make the affected part of the body move through the gravity and with the help of the unaffected limb to make the brain learn the movement of the leg.

Every day, the human initiates and executes coordinated movements for extraordinary achievement. Dynamically we can sync the upper and lower limbs, such as driving a car, reaching something and opening the container. However, for such a person, whose body is partial paralysis or weakness on one side due to Stroke, even simple interlink coordination works, such as washing clothes, wearing clothes, and eating.

In humans, there is abundant evidence of intuitive recovery of work during the first three months after the stroke originated from a complex pattern of brain reconstitution. Regarding general processes related to seamless motor recovery, three have been identified:

(a) Compensatory changes in the damaged hemisphere in the functional organization of intact cortical tissue surrounding myocardial infarction

(b) Activation of motor areas and ipsilateral corticospinal fibers in the unaffected hemisphere

(c) The activity of the supplementary motor areas such as supplementary motor area, inferior parietal cortex, cingulate, insula, and cerebellum increase.

An underlying assumption of the use of bilateral movement therapy is that symmetrical bilateral movements activate similar neural networks in both hemispheres when homologous muscle groups are simultaneously activated. When the upper extremity is used unilaterally, there is inhibition of the ipsilateral hemisphere, and the interhemispheric inhibition is specifically directed to prevent mirror movements by the opposite upper limb.

However, during symmetrical bilateral tasks, both hemispheres are activated, and intracortical inhibition is reduced. (29)

3.2. Chairish Concept 2

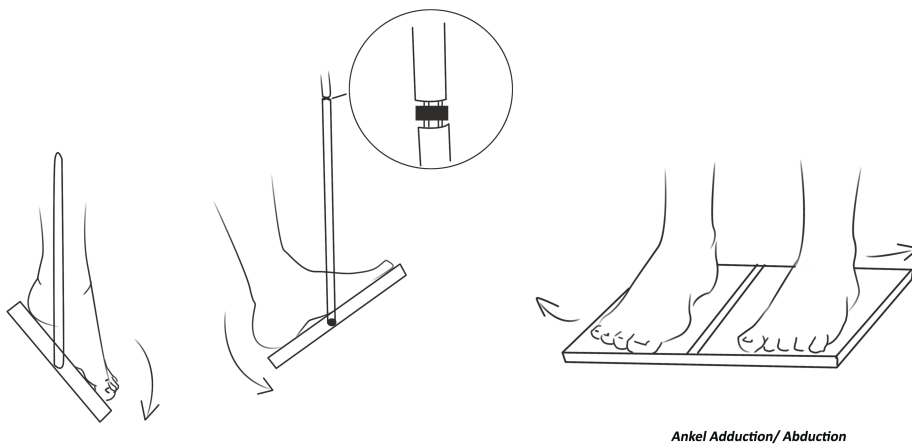
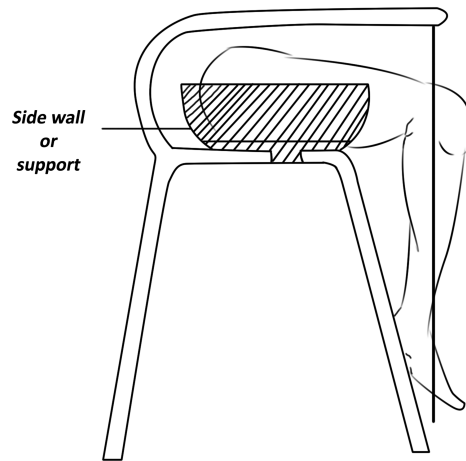

Ankel Adduction/ Abduction

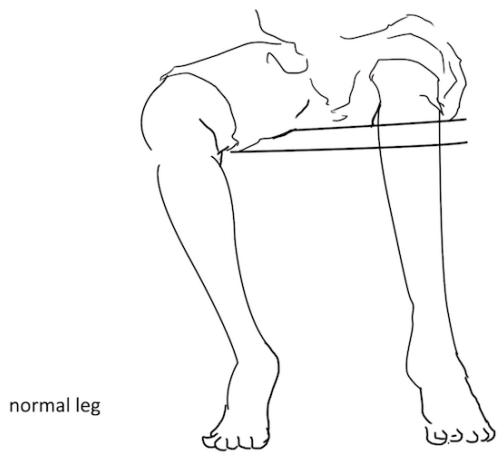
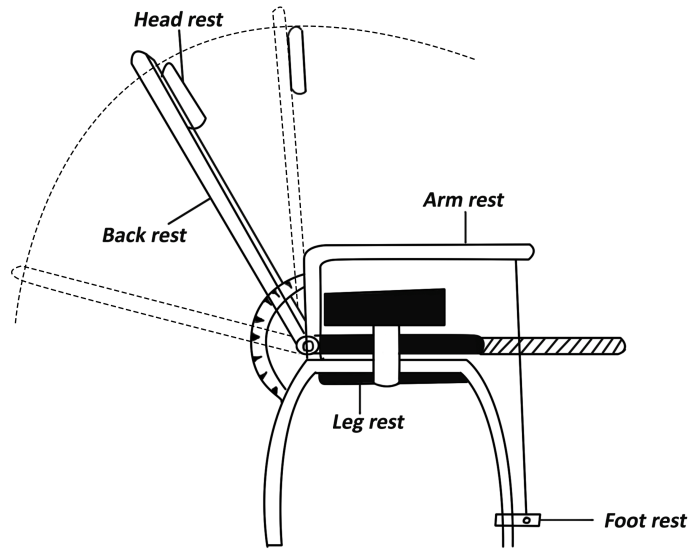

normal leg

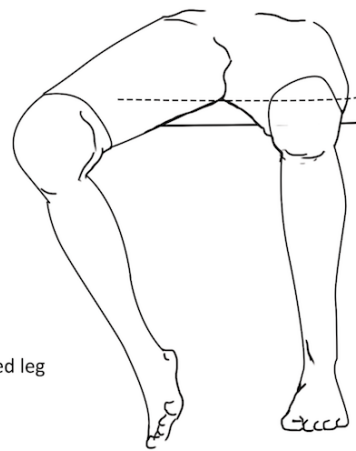

dropped leg

When the first design was made and discussed with the guide and the physiotherapist, many problems came in, and many additions were suggested by the physiotherapist, and according to the suggestion, we altered the device. Physiotherapist suggested that there are different stages of the stroke recovery and all stages are not being addressed by the designers for the device, they only focus on the good exercise part but because the primary issues were not addressed the secondary stage becomes more difficult for the patients to face. In the primary stage of the stroke, the body, because of stroke starts falling/drooping on the affected side as they have no sensation, and this results in the deformation of the body. Because the body constantly remains in one position for long, the muscles around the bones start to accumulate and make it the new neutral position, and when the patients come to the second stage of recovery, the patient was unable to walk properly because of their new body deformation parts. And to tackle this problem of deformation of the body, new things in the design were implemented in such a manner that the patient in their primary stage first, try to be in their neutral body postures.

The key additions to the new design:

- The swing wires were shifted to the armrest
- The slider was added to the chair legs to make it a bed
- Different belt positions were added as suggested by the physiotherapist
- The seat is designed considering the different body sizes

- Different materials were used for the swing holder

3.2.1 Design and functionality of Chairish concept 2

As suggested by the physiotherapist. The project addressed the primary issues of the patient, where patients body postures were tried to keep in a neutral position by adding additional gears to the footrest. (neutral postures are the one when a healthy person sits on the chair without any drooping or dislocation of the bone sockets) After stroke, when the primary issue was not solved, the patient tends to walk in some distorted way. Either he lifts his entire affected leg without any bending of the knee joint, or else he pushes him/herself by dragging the affected leg. The armrest was designed in such a way that the joint socket of the shoulder will come to its actual position without drooping. This practice, as suggested by the physiotherapist, has to be continued at least till a month after the stroke, before starting any motor recovery exercise.

3.3. Chairish Concept 3

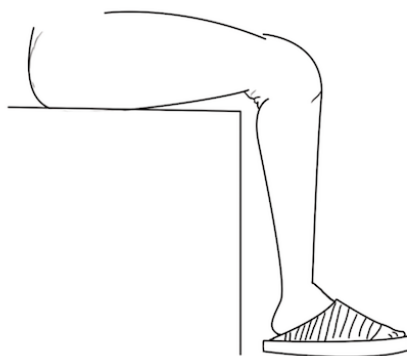
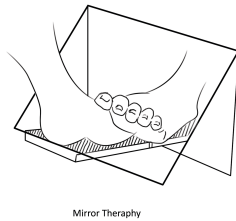
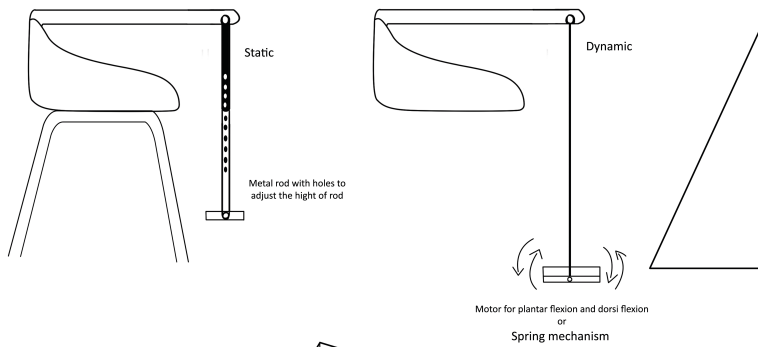
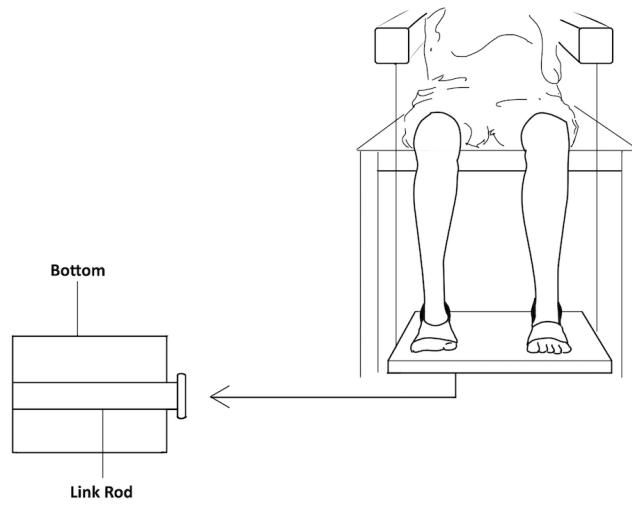

foot rest : to keep the joints at neutral

- Case : foot drop
- Nerve injury
 - Brain or Spinal injury
 - Muscle disorder

Chairish concept 3, added mirror therapy for the patients. As they have to sit for very long and considering their condition as there are many other problems like pressure sores (a condition where the body remains immobile for a long time and because of the weight of the body the area where skin touches the surface, cells of the skin began to die), for such condition, it was suggested to make the body movement in every 2 hours. Many new alterations were done, and new things were added to the new design.

The key addition to the Chairish concept 3:

- Addition of mirror therapy
- A sleek design of the chair
- Designed according to the industrial standard
- Exploration of foot paddle/board
- A motor device was an additional gear kept for later use.

3.3.1 design and functionality of Chairish concept 3

The design of the chair after many alteration and discussions concluded that we need a chair where the patient can easily lay down for hours without any problem. The

primary stage of the stroke where the body postures of the patients have to be kept in their neutral position to avoid the deformation for the affected side of the body parts.

In the second phase of therapy, the body of the patient becomes stiff and rigid at the joints and for that different stretching exercises have been suggested by the physiotherapists which include extension/flexion, dorsiflexion/plantarflexion, abduction/adduction of leg joints. The chair paddle/board is designed in such a way that the patient can do such exercises in that.

The mirror therapy was added as an extension of the chair, as it was suggested by the physiotherapist that the patient learn things by the senses which are active and the visual sense act more efficiently in this case because a human brain learns things in a better way, looking at it. Mirror therapy increases low-speed motor recovery and motor activity in sub-stroke patients combined with a traditional stroke rehabilitation program. (37)

In patients with stroke, mirror therapy involves performing the movements of an unspecified body, while its mirror is overlooking the (unseen) impaired organ, thus creating a visible illusion of the increased movement capacity of the impaired organ. (38)

We are still in the progressive stage and still need to refine the product. Still, need to do some clinical experiment for the refinement of the product.

3.4. Chairish concept 4

As part of exploration, keeping in mind the body posture and condition of patients. Apart from the design of the chair, the material was also one of the major factors which were essential for the comfort of the patient. As the task was to keep the patients in comfort and for very long with reducing the chance of having other immobility problems like pressure sores, the inflatable device for the patients was added with other functions of the chair constant.

2.10. The key addition to the Chairish concept 4

- Inflatable chair base and sides for support
- Cushioning for a better comfort
- Division of the sitting base in 2

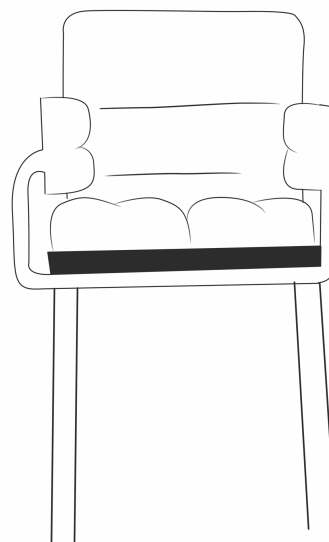

3.4.1. design and functionality of Chairish concept 4

Keeping all the functions constant only the material selection was different in this concept. The inflatable seat base was kept in

place as to give rest to the pelvis simultaneously one by one to reduce the chance of pressure sores as suggested by the physiotherapist that body when remaining constant in one position for long and the pressure and strain comes on single muscles, the cells of that part starts to die. To get rid of such situation, we need to move the position of the body in every 2 hours.

Chapter 4

4.1 Material selection for chair

The material of the chair is still yet to decide as according to the guidelines and physiotherapist it came to notice that if the patient has to sit for long and to sleep for long the material has to be very cozy and comfortable with the clinical criteria.

We did the study on what type of material would be good for the chair

We studied the standard beds to therapeutic hospital beds and for sitting, we studied the standard chairs, office chairs to the passenger seats (car, train, flights, etc.) their dimensions, ergonomics.

Because the situation is different, they can't be treated the same, as many other issues are there apart from sitting, comfort, and ergonomics. Still, the study is going on for the selection of the perfect material for the chair.

4.2 Tools used

For the concept development phase, everything started with the rough layouts with the pen, paper, pencil; later proper sketches are done on the a3 size sheets to demonstrate.





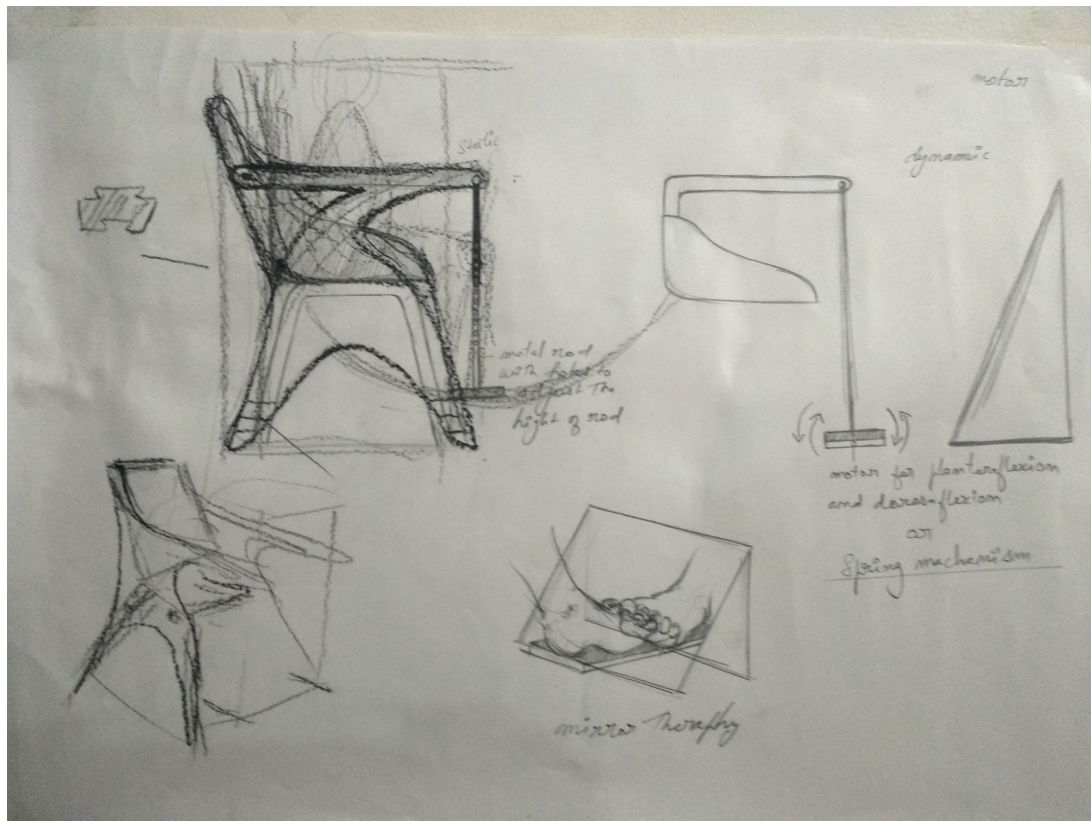

Concepts were explained on paper and presented on the reviews and as the suggestions came in, many alterations and additions were done on papers itself.

After the concepts were developed, digital drawings were made for the printing and presentations On Adobe illustrator and photoshop. CAD models were developed on the different 3d software's rhino and SketchUp this was the first attempt of mine on any 3d software and learned the basics of the software through video tutorials from YouTube and other channels.

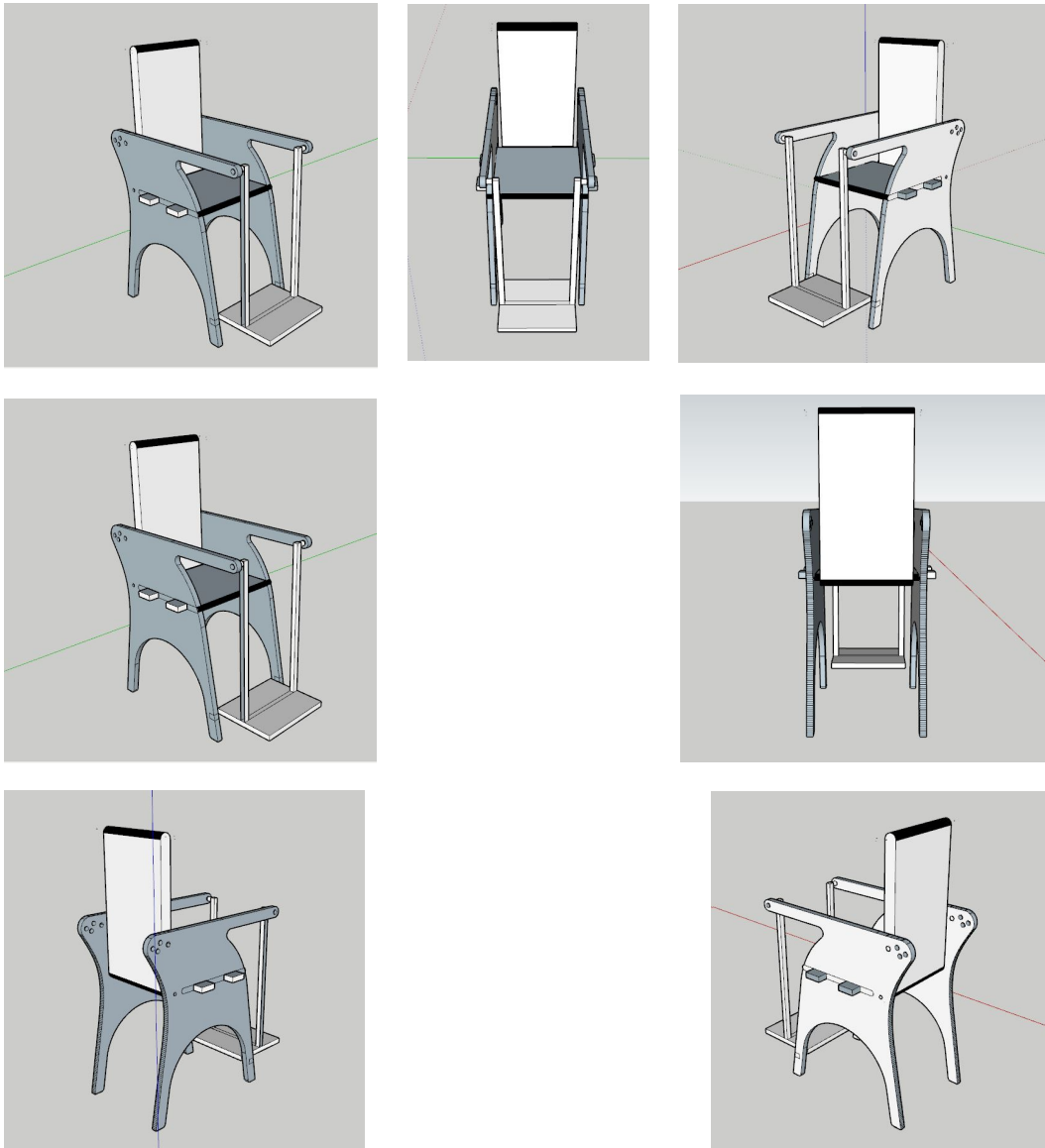

4.3 chair guidelines

It very well may be all around communicated without deception that the sitting position is the trademark for present day times. The primary purpose behind the advancement of seats was to diminish physical stretch on the body. With an even seat surface, a backrest edge of 125° is required to get a low pressure in the spine. The seat point and the back edge caused minimal worry in the spine. With expanding seat points, the backrest edge can be decreased without enlarging twisting of the spine. In reality, in case of sitting, we loosen up the legs, feet, and somewhat the muscles in the

storage compartment. As the fundamental criteria for the helpful seat for a stroke patient are to cause them to sit serenely for a more drawn out time. (31)

The following intradiscal pressure and low muscle activity are found in the chairs with the following characteristics:

Backrest inclination (to the horizontal line) 110-120 °

Seat surface inclination 14 °

Lumbar support 5 cm

We must assume that with the inclination of the backrest, one part of the body weight is shifted to the backrest, thus obtaining a decrease of the load on the discs as well as of muscle strain.

relaxation is identified with recognition, rich and prosperity, and fretfulness is identified with poor biomechanics, anxiety, and exhaustion. Stylish structure, delicacy, and non-abrasiveness are significant components of solace. The great seat configuration is in blend with great ergonomics and great feel. (32)

As a seat user sits, disc weight increments by around 40 - half contrasted with standing.

Nevertheless, since there are no nerve endings in the circles, most seat clients are unmindful of any development in weight.

At the point when an individual move towards sitting from the stand, the hip joint edge diminishes from 180 degrees to 90 degrees. Roughly 60 degrees of twisting happens in the joint of the hip, and the rest of the 30 degrees is consumed by the forward turn of the pelvis, which changes the bend of the lumbar. (33)

Therefore, the separation between the erector spinal muscle and the spine decreases, and to look after equalization, weight increments in the spine. To diminish the plate weight, a seat planner can attempt to reestablish the lumbar bend through the help of the lumbar, or by raising the back point, it can open the hip joint edge to 110 - 120 degrees. (34)

Therefore, with the support of the lumbar and the adjustable backrest angle, it has become common to design chairs, which will increase to 110 - 120 degrees.

There are two extra plan criteria; (1) The size of the seat ought to accord client size and (2) the seat ought to have a 'cascade' front, in this way keeping away from that the blood flow in the legs is cut off.

These criteria are more understandable for users to change disk pressure and can be used by potential customers.

It is moderately simple to evaluate the elements of solace, which are identified with style, inertness, and feeling of unwinding. The proposition is that when clients look at

changed seats, it is straightforward the distinction in solace and feel, yet the distinction in the bother isn't simple. Accordingly, clients may pick support at the expense of ergonomics. There should be a high backrest in the chair, and it is possible that the entire seat shell should be tilted further between 2 ° and 14 ° in the middle of the inclination. The concept of a flexible seat shell should be visualized in such a way that the user can easily decide on any desired angle.

The size of the back should be slightly concave on the top and must be convex in the lumbar area. We have good reason to believe that this type of chair supports the user in the lumbar region and gives a rebound on retreat. (36)

although numerous discussion have been made on the ergonomics of the chair and numerous standard estimations are available A Stroke is a neurological syndrome with a high prevalence in adults and elderly and one of the main causes of mortality in the world. chair dimensions are based on an average-sized adult

seat width- 16''-20.''

seat depth- 15''-18.''

seat height from floor- 16''-18.''

the slope of seat front to rear- 5 degree to 8 degrees (3/4'' to 1'' drop)

Armrest height above seat- 7''-9''

armrest length (full armrest)- 8'' minimum

armrest width- 2'' average

Set back of armrest from the front- 2''-3''

set back height- 12'' 16'' above the seat

seatback recline angle- 0 degree(formal), 10 degree – 15 degree (casual)

source: standard dimensions for furniture design

4.4. Prototype





Based on the literature studies, the prototype was made using the wooden plank, and the design was cut with the use of the CNC machine. Many alterations were done in the design of the device at the time of prototyping. The device can be used in many ways, even by normal people. The device is equipped with a table which can be used to have food or to study or to write or to use a laptop. The swing at the foot can be used for stress relief. A wheelchair has been referred for the dimension infusing the literature studies of the other standard dimensions of office and home chair.

The device can be dismantled and is so easy to keep anywhere as it does not occupy much space. The device has different parts like two side walls, 1 sitting base, one backrest, one support under the sitting base, 1 table plank on armrest, 1 swing with footrest and a mirror which all can be dismantled and used accordingly.

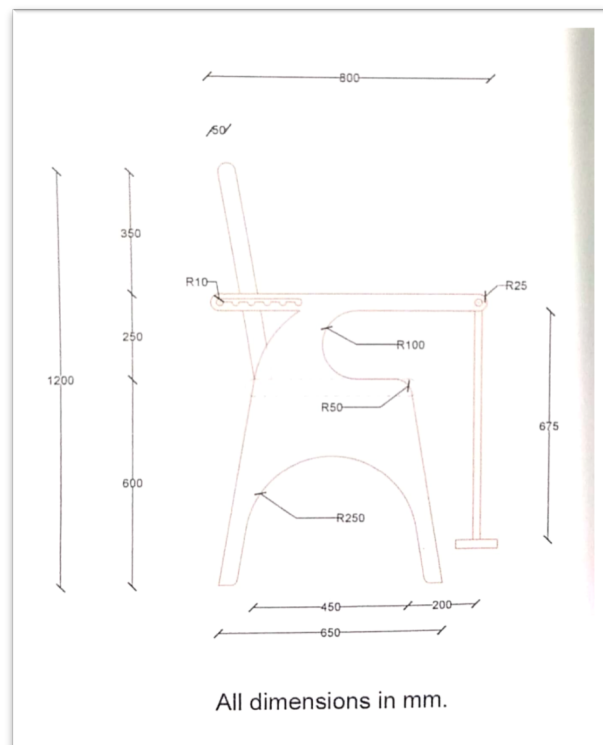

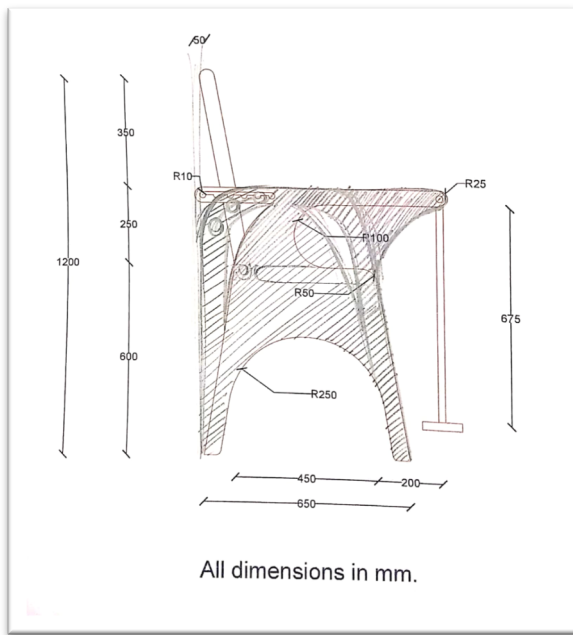
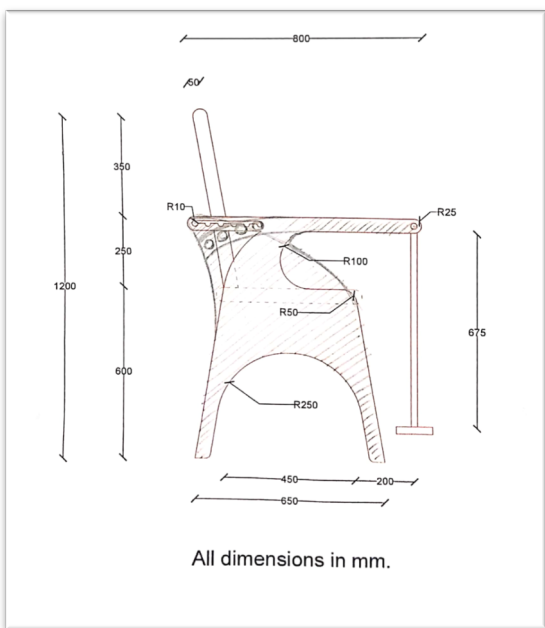
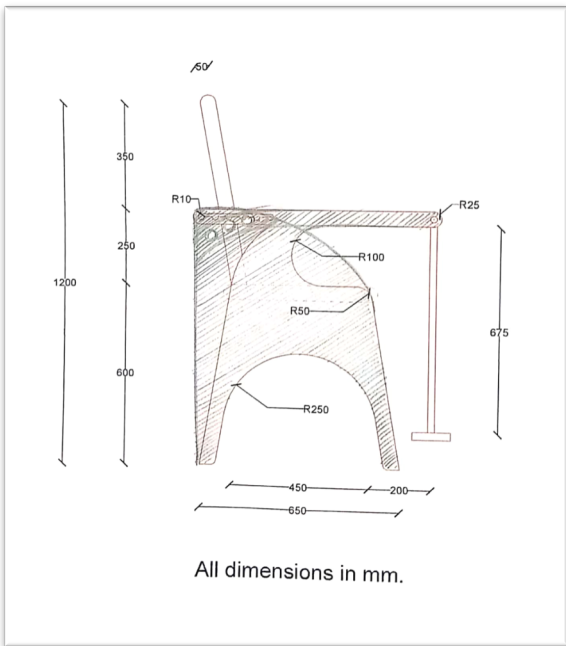
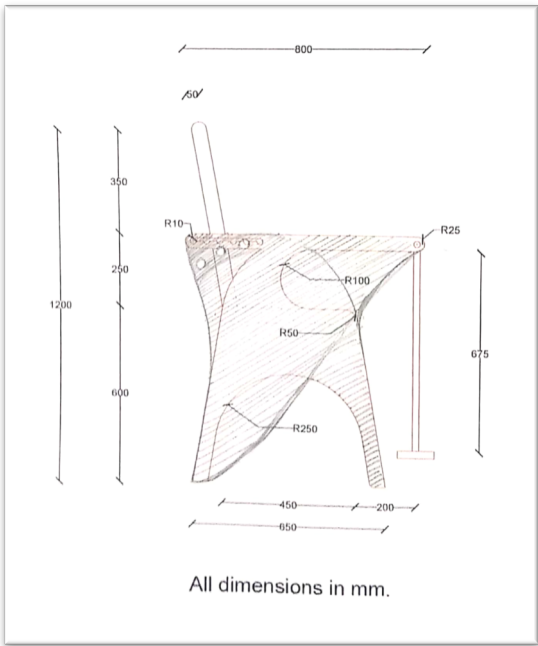

References

1. Stroke rehabilitation Peter Langhorne, Julie Bernhardt, Gert Kwakkel
2. The impact of stroke Charles D A Wolfe Department of Public Health Sciences, Guy's, King's and St Thomas' Hospitals School of Medicine, London, UK
3. Stroke: types, symptoms and treatment. YouTube
4. National Stroke association.
5. The use of transcranial direct current stimulation in stroke rehabilitation: effects on mood and cognition (March-April 2019)
6. Transcranial Direct Current Stimulation in Stroke Rehabilitation: Present and Future Oluwole O. AwosikaLeonardo G. Cohen January 2019
7. World Health Organization. Rehabilitation 2030: A Call for Action. Meeting Report [Internet]. Geneva (CH): WHO, 2017. <http://www.who.int/disabilities/care/rehab-2030/en> (accessed November 7, 2017).
8. Rehabilitation after stroke: evidence, practice, and new directions
Coralie English¹, Audrey Bowen², Debbie Hébert³, and Julie Bernhardt⁴
9. Benjamin EJ, et al. Heart disease and stroke statistics-2017 update: A Report from the American Heart Association. *Circulation*. 2017;135(10):146-603.
10. Langhorne P, Coupar F, Pollock A. Motor recovery after stroke: A Systematic review. *Lancet Neurol*. 2009;8(8):741- 54.
11. Franceschini M, et al. Is health-related-quality of life of stroke patients influenced by neurological impairments at one year after stroke? *Eur J Phys Rehabil Med*. 2010;46(3):389-99.

12. Rehabilitation after stroke: evidence, practice, and new directions

Coralie English¹, Audrey Bowen², Debbie Hébert³, and Julie Bernhardt⁴

13. World Health Organization. Rehabilitation 2030: A Call for Action. Meeting Report [Internet]. Geneva (CH): WHO, 2017. <http://www.who.int/disabilities/care/rehab-2030/en> (accessed November 7, 2017).

14. Royal College of Physicians and the British Society of Rehabilitation Medicine. Rehabilitation Following Acquired Brain Injury: National Clinical Guidelines (Turner-Stokes L, ed.). London: RCP, BSRM UK, 2003.

15. Lee, K., Lim, S., Kim, K., Kim, K., Kim, Y., Chang, W., ... Hwang, B. (2015). Six-month functional recovery of stroke patients: A multi-time-point study. *International Journal of Rehabilitation Research*, 38(2), 173–180.

16. Towards a Lower-Limb Rehabilitation System Based on Motor Imagery and Motorized Pedal for Stroke Patients

Maria Alejandra Romero-Laiseca, Vivianne Cardoso, Alexandre Pomer-Escher, Berthil Longo, Denis Delisle-Rodriguez, Sara S. G. Nascimento, Jéssica P. S. Lima, Flávia A. Loterio, Anselmo Frizzera-Neto, Teodiano Bastos-Filho

17. World Health Organization, “Stroke, Cerebrovascular accident,” 2017.

18. American stroke association

19. Post-stroke rehabilitationS Whitehead, MB ChB; E Baalbergen, MB ChB
Life Rehabilitation Unit, Vincent Pallotti Hospital, Cape Town, South Africa

20. Bates B, Choi JY, Duncan P, et al. Veteran Affairs/Department of Defence clinical practice guideline for the management of adult stroke rehabilitation care: Executive summary. *Stroke* 2005;36(9):2049-2056.

21. Duncan P, Zorowitz R, Bates B, et al. Management of adult stroke rehabilitation care: A clinical practice guideline. *Stroke* 2005;36(9):100-143. <https://10.1161/01.STR.0000180861.54180.FF>
22. Bryer A, Connor M, Haug P, et al. South African guideline for the management of ischaemic stroke and transient ischaemic attack 2010: A guideline from the South African Stroke Society (SASS) and the SASS Writing Group. *S Afr Med J* 2010;100(11):750-776. <https://doi.org/10.7196/samj.4422>
23. Booth J, Hewison A. Role overlap between occupational therapy and physiotherapy during in- patient stroke rehabilitation: An exploratory study. Abstract, Qualitative Based Practice Conference. Coventry University, UK, 14 - 16 May 2001. *J Interprof Care* 2002;16(1):31-40. <https://doi.org/10.1080/13561820220104140>
24. Poverty and Stroke in India A Time to Act Jeyaraj D. Pandian, DM; Velandai Srikanth, FRACP; Stephen J. Read, FRACP; Amanda G. Thrift, PhD
25. Aggarwal VK, Basannar DR, Singh RP, Dutt M, Abraham D, Mustafa MS. Coronary risk factors in a rural community. *Indian J Public Health*. 2006;50:19 –23.
26. Indian economy overview. Available at: www.economywatch.com/indianeconomy/indian-economy-overview.html. Accessed July 13, 2007
27. Murray CJ, Lopez AD. Alternative projections of mortality and disability by cause 1990–2020: global burden of disease study. *Lancet*. 1997;349: 1498–1504.
28. Feigin VL. Stroke in developing countries: can the epidemic be stopped and outcomes improved? *Lancet Neurol*. 2007;6:94 –97

- 29 Cauraugh, J. H., & Summers, J. J. (2005). Neural plasticity and bilateral movements: A rehabilitation approach for chronic stroke. *Progress in Neurobiology*, 75(5), 309–320.
30. *The Immobilized Patient: Functional Pathology and Management* By Franz U. Steinberg
- 31 Helander, M. G. (2003). Forget about ergonomics in chair design? Focus on aesthetics and comfort! *Ergonomics*, 46(13-14), 1306–1319.
- 32 ANDERSSON, G. B. J., O' RTENGREN, R. and NACHEMSON, A. 1979, Studies of Back Loads in Fixed Spinal Postures and in Lifting, in C. G. Drury (ed.), *Safety in Manual Materials Handling*, (Cincinnati, OH: US Department of Health, Education and Welfare, NIOSH), 26 – 33.
33. MICHEL, D. D. and HELANDER, M. G. 1994, Effects of Two Types of Chairs on Stature Change and Comfort for Individuals with Healthy and Herniated Discs. *Ergonomics*, 37, 1231 – 1245.
34. HELANDER, M. G. and ZHANG, L. 1997, Field Studies of Comfort and Discomfort in Sitting, *Ergonomics*, 40, 895 – 915.
35. Grandjean, E., & Hünting, W. (1977). Ergonomics of posture—Review of various problems of standing and sitting posture. *Applied Ergonomics*, 8(3), 135–140.
36. Drury, C. G., & Coury, B. G. (1982). A methodology for chair evaluation. *Applied Ergonomics*, 13(3), 195–202.
37. *Mirror Therapy Enhances Lower-Extremity Motor Recovery and Motor Functioning After Stroke: A Randomized Controlled Trial*
Serap Sütbeyaz, MD, Gunes Yavuzer, MD, PhD, Nebahat Sezer, MD, B. Füsün Koseoglu, MD

38. Stevens JA, Stoykov ME. Using motor imagery in the rehabilitation of hemiparesis. *Arch Phys Med Rehabil* 2003;84:1090-2.