

# **-Miniaturization of PCR Machine -**

**-ARVIND KUMAR SINGH-**

A Dissertation Submitted to  
Indian Institute of Technology Hyderabad  
In Partial Fulfillment of the Requirements for  
The Degree of Master of Technology



भारतीय प्रौद्योगिकी संस्थान हैदराबाद  
Indian Institute of Technology Hyderabad

Department of Electrical Engineering

July, 2018

---

## Declaration

I declare that this written submission represents my ideas in my own words, and where others' ideas or words have been included, I have adequately cited and referenced the original sources. I also declare that I have adhered to all principles of academic honesty and integrity and have not misrepresented or fabricated or falsified any idea/data/fact/source in my submission. I understand that any violation of the above will be a cause for disciplinary action by the Institute and can also evoke penal action from the sources that have thus not been properly cited, or from whom proper permission has not been taken when needed.



\_\_\_\_\_  
(Signature)

ARVIND KUMAR SINGH

EE16MTECH1016

(Roll No)

## Approval Sheet

This thesis entitled Miniaturization of PCR Machine by Arvind Kumar Singh is approved for the degree of Master of Technology from IIT Hyderabad.



- Dr. Gajendranath Chowdari -  
Examiner



- Dr. Shiv Govind Singh -  
Adviser

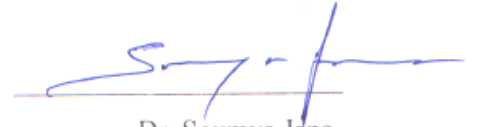

-Dr. Soumya Jana-  
Chairman

## **Acknowledgements**

I would like to thank God for keeping me in good health and for all the grace. I would like to thank my brother and my parents for always being supportive.

I express my deepest gratitude to my guide prof. Dr. Shiv Govind Singh Sir for valuable guidance, constant support and motivation which helped me in the completion of my thesis. He has always been there when I had doubts. His wisdom and guidance has led me path to achieve success in this project work.

I thank to Dr. Vijay Shantaram Duryodhan sir and prof. Dr. Gajendranath Chowdari for their guidance and teachings. I want to take this opportunity to thank all the professors in the Electrical Department, IIT Hyderabad for their great help and support.

I wish to sincerely thank my family and friends for keeping faith in me and encouraging me throughout my work.

Dedicated to

My brother, Harish Kumar Singh for his constant support. If it wasn't for him, I wouldn't be as strong as I am. It's not mine but his persistence and perspiration which paid off in bringing success to my life.

## **Abstract**

The polymerase chain reaction (PCR) is a technique defined for copying specific DNA sequences. The three basic steps in that process - splitting a DNA template into its two single strands (called denaturation); adding short segments of complementary DNA called primers to initiate replication of a chosen DNA sequence (annealing); and adding DNA polymerase to synthesis the complementary strand (called extension) - are repeated again and again to amplify the sequence. Each of these steps occurs optimally at a different temperature, so heating and cooling is carried out with an instrument called a thermal cycler. Better than the conventional big size PCR here we have designed a circuit which is capable of performing fast temperature rise and fall and that is within small region. This design supports the easy transportability of the machine because of its smaller size with very low design cost.

## **Nomenclature**

dNTP – Deoxyribonucleotide triphosphate

dATP – deoxyAdenosine 5'-triphosphate

dGTP – deoxyGuanine 5'-triphosphate

dTTP – deoxythymidine 5'-triphosphate

dCTP – deoxycytidine 5'-triphosphate

## Contents

1) Introduction to PCR.....	1
Motivation .....	1
2) Literature survey .....	2
How does PCR work?.....	3
3) Circuit for Temperature control.....	10
Block diagram.....	10
1. TEMPERATURE SENSOR.....	10
2. HEATER .....	11
3. LCD display:.....	11
4. Microcontroller ATmega32:.....	12
5. Human Interface through keypad: .....	18
6. Circuit Diagram: .....	20
7. Other major components used in the circuit .....	22
4) Results and Discussion .....	25
4.1 Simulation in COMSOL Multiphysics .....	25
5) Future Scope .....	30



# Chapter 1

## Introduction to PCR

### **Motivation**

The world is full of a lot of infectious and harmful insects, bacteria and viruses. Everyday new kind of these small harmful creatures is being detected, much more than our capacity of discovering vaccines and treatment against them. The presence of bacterias in minimally processed generally, pure quality or improperly stored foods in food storage chambers is natural and unavoidable. Some of these bacterias (or food pathogens) may cause us serious and cost-generating health threat. Dangerous for human infectious dose of these kinds of pathogens is very low (about 10 bacterias) and the time of incubation of pathogens-borne illnesses is very short. Therefore, it is crucial to rapidly detect these pathogens at the primary infectious point and all potentially possible hazardous places.

This goal may be reached only by applying the detection process for mass-scale and for cheap food pathogens tests. Conventional microbiological tests are accurate and reliable other than they are mostly being done by the heavy and bigger PCR machines. However, they are mostly time-consuming (7–10 days) and carried out only in the specialized laboratories like in the research labs or in the reputed institutions and hospitals. The second commonly applied method of food pathogens detection is analyzation of their DNA.

In this method, the fragments of DNA extracted from bacteria (template DNA) are amplification in polymerase chain reaction (PCR). Since the conventional PCR machine are bigger in size and that is why not easily transportable that is why we have designed a effectively smaller PCR circuit which can be equipped with the heater section and can be transported easily.

# Chapter 2

## Literature survey

Nucleic acid amplification reaction such as PCR has emerged as powerful tool in a variety of genetic analyses, medical diagnostics, and forensic applications. This technique is able to dramatically increase the concentration of target nucleic acid of interest, which is initially present at low levels in most cases. For example, a single target DNA molecule can be amplified up to  $10^6$  by PCR. PCR involves the repetition of heating (denaturation) and cooling (annealing) cycles in the presence of a target DNA, two primers, de-oxy-nucleotides, a polymerase and various co-factors.

Prior to the development of 1980s, the primary method of producing many copies of a gene was a relatively far more time consuming process called as DNA cloning. This technique involved insertion of gene of interest into the living cell, which replicated the gene along with their own DNA during the two processes called division and replication. Nowadays scientists produces enough specific segments of a DNA for their research mostly by using POLYMERASE CHAIN REACTION (PCR).

It is their method of choice for the quick generation of the scientific amount of identical genetic materials (specific segments of DNA) for the research and also for the purpose of study because as compared to the previous process of DNA cloning in PCR process we don't get the bacterial cell's DNA amplified along with our targeted DNA but we only get our targeted DNA amplified. That is what makes this process more useful for the research.

PCR makes it possible to produce billions of copies of a DNA sequence in a test tube in just few hours, even then when we use a very small initial amount of DNA. PCR has revolutionized molecular biology, and is has now become the very essential tool for the biologists and physician or whoever is working with the DNA or DNA amplification.

## How does PCR work?

PCR, sometimes also referred as “Molecular Photocopying”. The working of the PCR depends on the several key chemical components.

- 1) DNA – Deoxyribonucleic Acid, it is a thread like chain of nucleotides that carries the genetic information about growth, development, functioning and reproduction of all known living organisms and viruses.
  - i) A small amount of DNA which serves as the initial template or the target sequence
  
- 2) DNA Polymerase – These are the enzymes which synthesizes DNA molecules from nucleotides. These enzymes works in pairs to create two identical DNA strands from a single original DNA molecule, called as template. These enzymes should have high fidelity to replicate the DNA effectively and producing error free sequences of DNA.
  
- 3) dNTP<sup>[5]</sup> – Deoxyribonucleotide Triphosphate, each dNTP consists of a phosphate group. There are four types of dNTPs which are divided in to two groups, named as Purines & Pyrimidines.
  - i) Purines –
    - (a) dATP – deoxyAdenosine 5'-triphosphate
    - (b) dGTP – deoxyGuanine 5'-triphosphate
    - (c) Adenine(A) & Guanine(G) are the bases which features in Purines.
  
  - ii) Pyridimines –
    - dTTP – deoxythymidine 5'-triphosphate
    - dCTP – deoxycytidine 5'-triphosphate
    - Thymine(T) & Cytosine(C) are the bases which features in Pyridimines.

The double helix structure of the DNA is made up to these four types of dNTPs. If we unwound the DNA and imagine it as a ladder then phosphate groups with alternate deoxyribose sugar groups will be the sides of the ladder. The two bases attach with the hydrogen bonds to make a rung. *A* is always attached to *T* & *G* with *C*. Thus the number of *A* in a DNA sample is always equal to the *T* and vice-versa for *G* & *C*. The percentage of *A* or *T* plus the percentage of *G* or *C* is always 100% in any DNA.

**Primer** – A pair of primers that is designed to bind each end of the target DNA sequence. A good primer is essential for a successful replication and high yield of the DNA.

The few important preferred parameters of the primer are Primer length, Melting Temperature, Secondary Structure, 3' Stability etc.

**Essential Salts & Ions** – During the extension step of the PCR, the primer has to stick properly to the template. The  $K^+$  ions in the KCL salt functions by reducing the repulsion between the negatively charged primer and template, this way it stabilizes the primer-template binding. Also, Chen et al. in 1995 showed that by reducing the KCl concentration to 10 - 40% helped in increasing the efficiency of long DNA template amplifications. Therefore keeping a moderate concentration level of KCl is very important in amplification of the DNA.

Almost all polymerases require divalent cations for their activity. dNTPs bind to  $Mg^{2+}$ , therefore the concentration of  $MgCl_2$  can help to exceed the molar concentration of phosphate groups that are contributed to both the primers & dNTPs. This can result in high fidelity of the amplification.

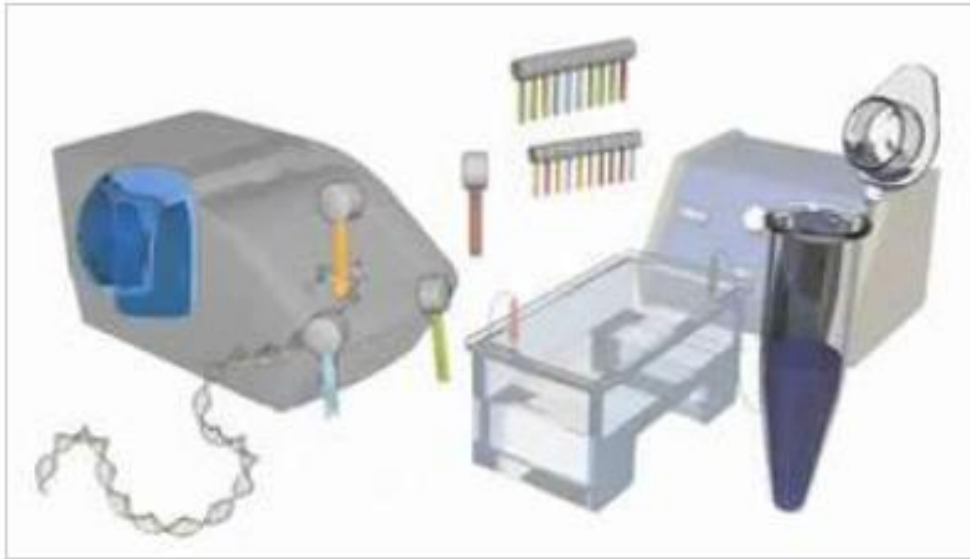

Fig 2.1: Components for PCR

The PCR process uses the above given ingredients to mimic the natural DNA replication process that occurs in cells. To automate this process, a machine called thermo-cycler which Jump-starts from each stage of the reaction by raising and lowering the temperature of the chemical components at specific times and for a preset number of cycles.

A simple user interface has been provided for user-configurable functions with the help of a LCD display and only three push buttons. The unit can be configured according to the specific requirements such as temperature cycling, individual cycle time and the number of cycles to be run.

Each cycle of PCR has mainly three steps, as described in the following sections.

### Step 1: Denaturation

In the first step of PCR, the initial solution is heated up to the necessary temperature, that is usually between 92 and 95C. As the temperature rise, it starts breaking the bonds joining the two strands of the DNA double helix, thereby enabling the DNA to separate into two single strands. This “melting” of the DNA into single strands is called denaturation (Fig. 2)

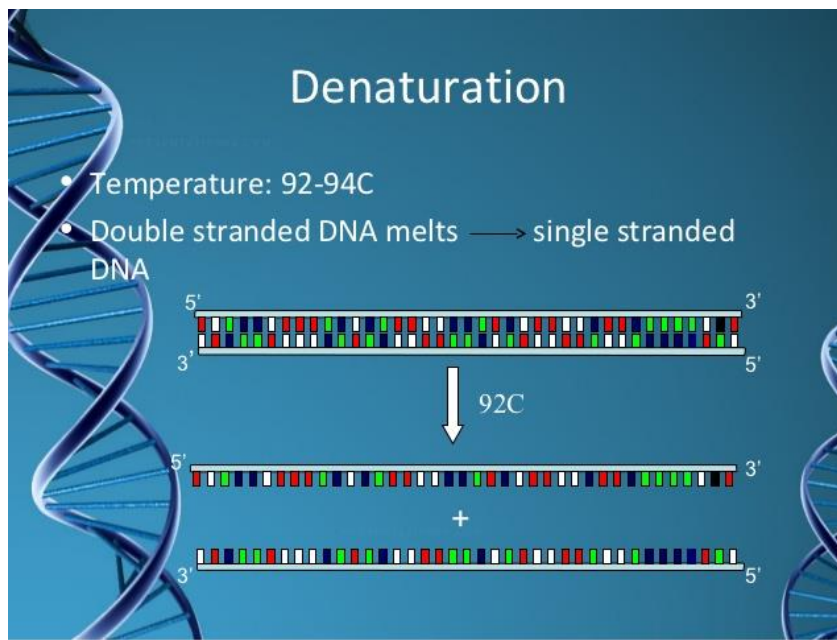

Fig-2.2: Denaturation

### Step 2: Annealing

After reaching the temperature  $\sim 94^{\circ}\text{C}$  it is held for several minutes at the initial target temperature, the reaction mixture is quickly cooled, usually to between  $50^{\circ}\text{C}$  and  $65^{\circ}\text{C}$ . The mixture is then held for less than one minute at this temperature. This gives the primers an opportunity to bind, or anneal, to their complementary sequences on the single strands of DNA (Fig 3).

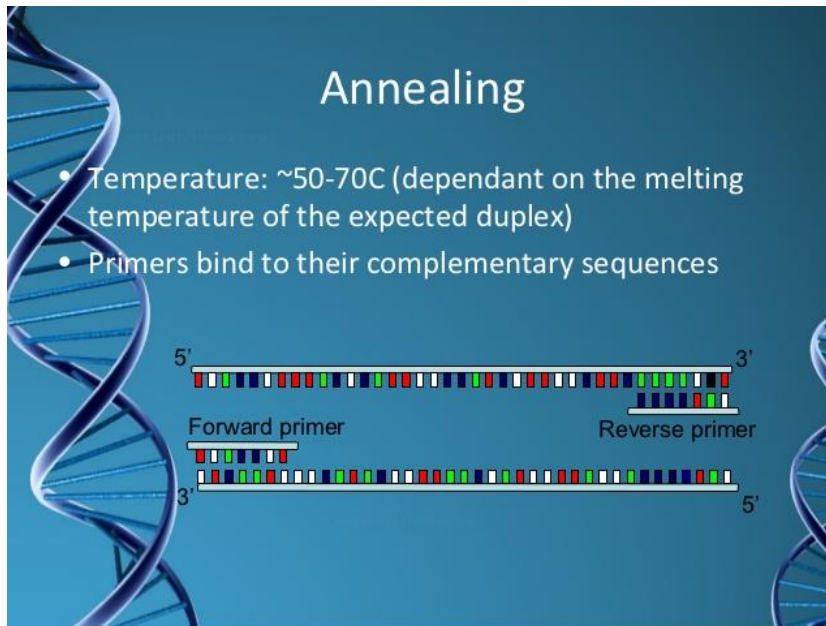

Fig.2.3: Annealing

### Step 3: Extension

During the final or extension stage of the PCR, the sample is heated again, usually between 60 and 75 C, and it is held at that temperature for less than one minute and it depends on the sample. At that point, the DNA polymerase starts making a new DNA strand by attaching to the primers and then adding dNTPs to the template strand, thereby creating a complimentary copy of the target sequence (Fig. 1.4).

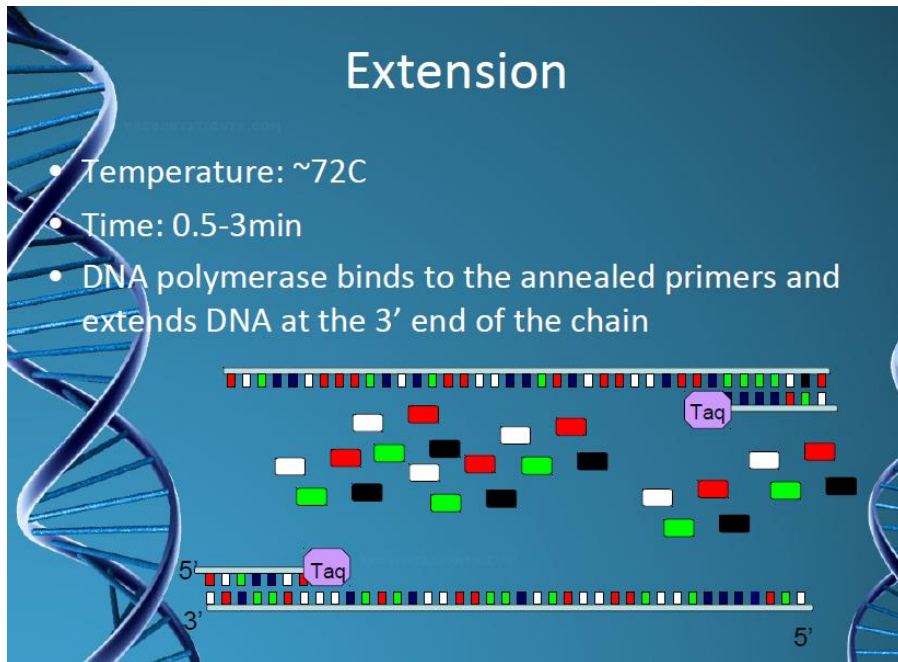

Fig-2.4: Extension

The number of new copies of DNA sequence of interest doubles with each three-step cycle. Thus, if the PCR process is repeated 40 or 50 times, even very small initial samples of template DNA can yield more than millions of identical copies (Fig. 5).

PCR is an incredibly versatile technique for DNA replication with many practical applications. Once PCR cycling is complete, the copied DNA molecules can be used for many applications like cloning sequencing, mapping mutations, or studying gene expression.

Recently, PCR has proven useful in ways beyond mere copying and propagating identical segments of DNA. Today, geneticists rely on PCR to aid in the study of genes themselves.



## 1.1 Problem statement

To design a user defined programmable circuit with LCD, capable of performing the fast pace temperature changes with fast feedback response according to the user requirements like time, temperature and number of cycles.

## 1.2 Contribution of the thesis

In our project we have designed a fully functional circuit using ATmega32 microcontroller, which is capable of keeping the three temperature ranges for the variable time along with a user-defined number of cycles the circuit. ATmega32 is an 8-bit microcontroller with 32\*8 general purpose working registers, 1024Bytes EEPROM and 2Kbytes internal SRAM. Since the PCR machine is all about controlling the temperature so we have used the 10bit ADC available in ATmeg32 to control the temperature by generating a PWM (pulse width modulation) wave. By using the low cost temperature sensor LM35, we are keeping the track of the temperature of the centrifuge tube contained sample and giving it back as a feedback signal so that we can control the temperature with the help of PWM wave. Live temperature along with the individual stage temperature and the cycle number is clearly visible in real time on the display.

Not only the circuit part but the heater and centrifuge part integration is also studied. This work gives an idea of how the heater can be implemented with use of a microcontroller circuitry. This work demonstrates the combination of circuit design, heater design and coding beautifully.

# Chapter 3

## Circuit for Temperature control

### Block diagram

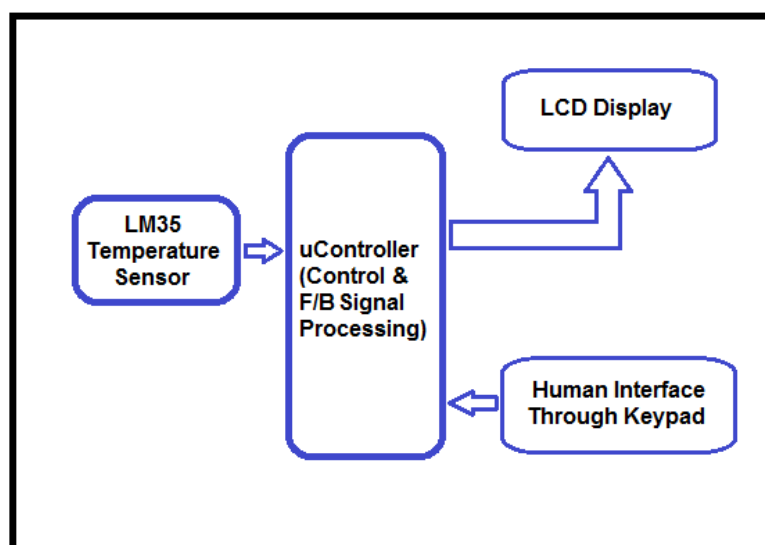

Fig.-3.1: Block diagram of circuit

### 1. TEMPERATURE SENSOR:

Here we have used a very low cost LM35 sensor. The LM35 is precision integrated-circuit temperature device with an output voltage linearly proportional to the Centigrade temperature. The LM35 device does not demand any external calibration or trimming to provide the typical accuracies of  $\pm 1/4^{\circ}\text{C}$  at room temperature and  $\pm 3/4^{\circ}\text{C}$  over a full  $-55^{\circ}\text{C}$  to  $150^{\circ}\text{C}$  temperature range but we have used that sensor IC in the basic centigrade range i.e. from  $2^{\circ}\text{C}$  to  $150^{\circ}\text{C}$  with a single power supply. In our application we have used max temperature  $95^{\circ}\text{C}$  that is dependent on the sample we are going to put in the centrifuge tube. Another important characteristic of the LM35 is that it draws only 60 micro-amps from its supply and possesses a low self-heating capability.

## 2. HEATER

PCR successful rate for making good replicates of the DNA template is highly dependent on the heater design. We have studied various kinds of solutions to provide rapid change in the heat of the template/centrifuge tube. In which the Nichrome wire was the perfect for our application due to the rapid heating capability, low power, very small form factor, no external heat sink requirement and a very low cost solution.

Nichrome wire as heater can be easily controlled by the varying the duty-cycle of the power supply i.e. by generating PWM.

Nichrome Wire Specifications <sup>[5]</sup>:

- a) Gauge – 37 AWG
- b) Resistance/Foot -  $35\Omega$
- c) Total Resistance -  $17\Omega$
- d) Length – 15 mm
- e) Temperature –  $150^{\circ}\text{C}$
- f) Power Supply – 5V DC, 1.5Watts

The nichrome wire to be wounded through fiber glass heat resistant sleeve on to the copper centrifuge holder for preventing the short circuit. Copper centrifuge holder is to provide maximum temperature to the centrifuge tube in which the DNA template taken.

## 3. LCD display:

It is a 16x2 LCD display that is two-line display with 16 characters in a line. The LCD provides a cost effective way to provide human machine interface. The LCD can show the informative messages that helps the user to configure the unit as per their requirement and in run mode, the LCD shows the live temperature that is being controlled, current cycle number and total elapsed time.

The LCD works on 5V DC supply and has backlit that helps viewing the display in low light environment. A potentiometer also has been provided to adjust the brightness of the LCD.

This LCD has the parallel interface, i.e. there are 8 data pins and three control pins to be connected to microcontroller, but to save the I/Os of the microcontroller, we have used the LCD in 4-bit mode. By using the LCD in 4-bit mode, we have saved 4 I/Os of the microcontroller.

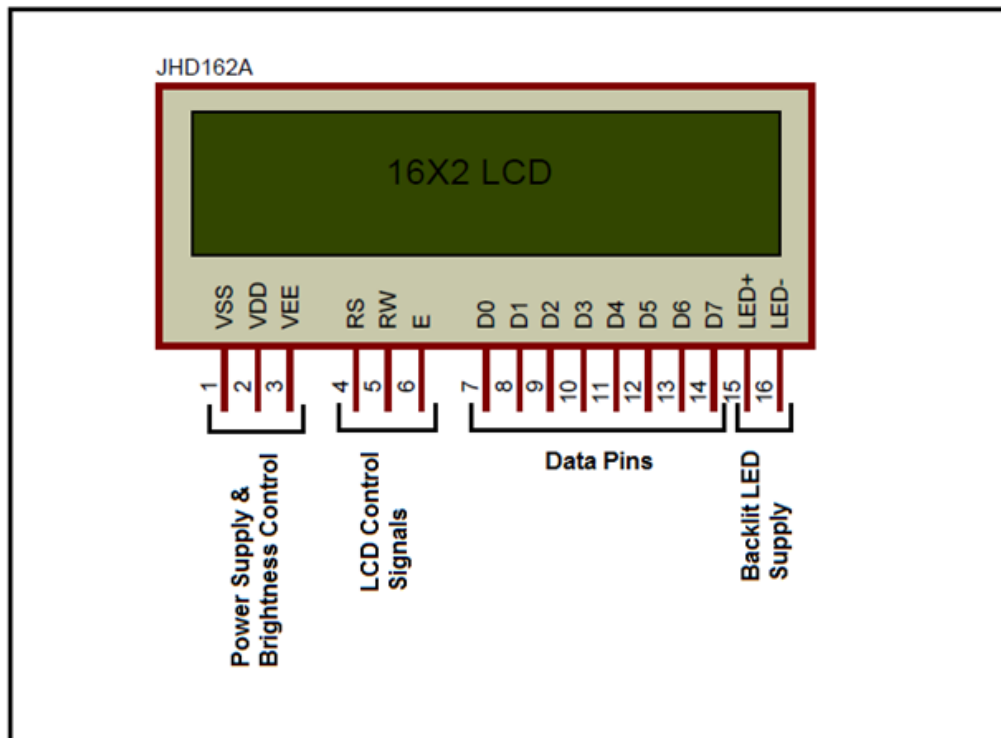

Fig.3.2 : JHD 16\*2A display

The LCD pin-out diagram 2.2 is shown above which gives an idea for the connections to be made between the LCD display and microcontroller.

#### 4. Microcontroller ATmega32:

ATmega32 is an 8-bit high performance microcontroller of Microchip (earlier, Atmel) Mega AVR family. Atmega32 is based on enhanced RISC (Reduced Instruction Set Computing) architecture with 131 powerful instructions. Most of the instructions execute in one machine cycle. Atmega32 can work on a maximum frequency of 16MHz and other than that these are some key features of ATmega32 IC are,

- 1) 8-bit Microcontroller
- 2) 32\*8 general purpose working registers
- 3) 1024Bytes EEPROM
- 4) Data retention for 20 years at 85°C/100 years at 25°C
- 5) 32 Programmable I/O Lines
- 6) On-chip Analog Comparator
- 7) Real Time Counter with Separate Oscillator
- 8) Four PWM Channels, 8-channel
- 9) 10-bit ADC and
- 10) 2Kbytes internal SRAM.

The pin-out diagram of the IC ATmega32 is given below

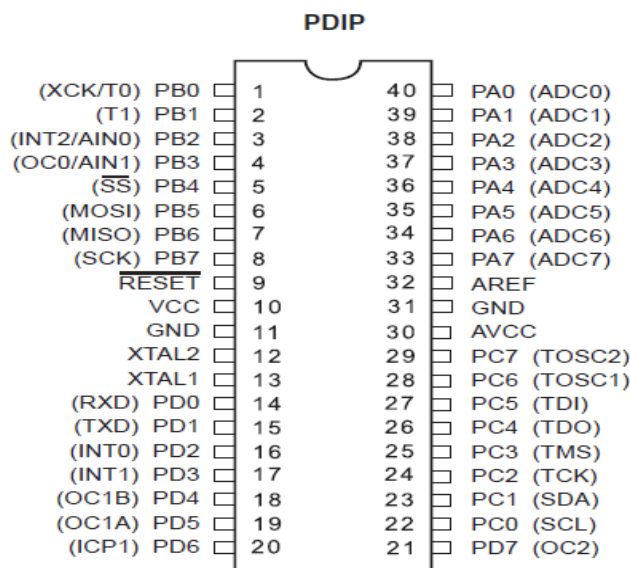

Fig. 3.3: Pinout ATmega32

The system clock of 4 MHz has been used in the design by making use of microcontroller's internal R-C Oscillator for lower cost and space constraints.

ATmega32 has inbuilt 8 Channel 10-bit ADC (Analog to Digital Converter) of successive approximation type. We have used a single channel of the ADC port of the ATmega32, i.e. PORTA to measure the analog output generated by the temperature

sensor LM35. The analog voltage generated by the LM35 is proportional to the temperature.

The accuracy specifications of LM35 are given with respect to a simple linear transfer function<sup>[6]</sup>:

$$V_{out} = 10mV/^{\circ}C$$

Where,  $V_{out}$  is the LM35 output Voltage

T is the temperature in  $^{\circ}C$

The ADC reference has been used as the internal band gap reference of ATmega32, i.e. 2.56V.

The ADC reference voltage is selected as shown in the ATmega32 datasheet.

**Table 83.** Voltage Reference Selections for ADC

REFS1	REFS0	Voltage Reference Selection
0	0	AREF, Internal Vref turned off
0	1	AVCC with external capacitor at AREF pin
1	0	Reserved
1	1	Internal 2.56V Voltage Reference with external capacitor at AREF pin

The reference selection in the compiler is configured as,

```
#define ADC_VREF_TYPE 0xC0
```

For single ended conversion, the result is

$$ADC = \frac{V_{IN} \cdot 1024}{V_{REF}}$$

The service routine function to take the samples of the analog voltage at Channel0 is written in the firmware as,

```

192 // Read the AD conversion result
193 unsigned int read_adc(unsigned char adc_input)
194 {
195     ADMUX=adc_input | (ADC_VREF_TYPE & 0xff);
196     // Delay needed for the stabilization of the ADC input voltage
197     delay_us(10);
198     // Start the AD conversion
199     ADCSRA|=0x40;
200     // Wait for the AD conversion to complete
201     while ((ADCSRA & 0x10)==0);
202     ADCSRA|=0x10;
203     return ADCW;
204 }

```

Whenever required, we can call the function **read\_adc(0)** to take the sample at channel0. This function will return a corresponding code in 10-bit scale.

This ADC code can be decoded to the measure the analog input voltage as,

$$\mathbf{V_{in} = (ADC\ Code/1023) \times 2560mV}$$

Then we can easily calculate the temperature by,

$$\mathbf{T = V_{in}/10}$$

Where, **T** is the temperature in degree Centigrade

**V<sub>in</sub>** is the calculated ADC input voltage in milli-volts.

This IC has three timer/counter modules in which one is 16 bit and the other two are 8 bit. Each timer has a prescaler or known as input clock divider which can be configured as per the requirement as given in the ATmega32 datasheet, also shown below.

**Table 48.** Clock Select Bit Description

CS12	CS11	CS10	Description
0	0	0	No clock source (Timer/Counter stopped).
0	0	1	clk <sub>IO</sub> /1 (No prescaler)
0	1	0	clk <sub>IO</sub> /8 (From prescaler)
0	1	1	clk <sub>IO</sub> /64 (From prescaler)
1	0	0	clk <sub>IO</sub> /256 (From prescaler)
1	0	1	clk <sub>IO</sub> /1024 (From prescaler)
1	1	0	External clock source on T1 pin. Clock on falling edge.
1	1	1	External clock source on T1 pin. Clock on rising edge.

The 16 bit timer/counter **TIMER1** is used for the time reference, i.e. to generate the 1 sec timer. The **TIMER1** is used to generate the interrupt at a precision time interval of 1 second.

For precision of the interval, high frequency system clock source has been used for Timer1 reference clock.

The configuration of the 16-bit Timer/Counter1 is,

**Timer1 Reference Clock Source : Internal System Clock**

**Prescaler/Clock Divider : 1024**

**Mode : CTC (Clear Timer on Compare Match)**

**CTC Top Value (OC1A) : 3096**

Since we have used system clock of 4Mhz & Prescaler used is 1024. Therefore the timer system clock value will be =  $4\text{MHz}/1023 = 3096\text{ Hz}$ . Hence the value of OC1A (16-bit Output Compare Register A for Timer1) is 3096.

The configuration of the Timer1 registers is shown below.

```
259 // Mode: CTC top=OCR1A
260 // OC1A output: Discon.
261 // OC1B output: Discon.
262 // Noise Canceler: Off
263 // Input Capture on Falling Edge
264 // Timer1 Overflow Interrupt: Off
265 // Input Capture Interrupt: Off
266 // Compare A Match Interrupt: On
267 // Compare B Match Interrupt: Off
268 TCCR1A=0x00;
269 TCCR1B=0x0D;
270 TCNT1H=0x00;
271 TCNT1L=0x00;
272 ICR1H=0x00;
273 ICR1L=0x00;
274 OCR1AH=0x0C;
275 OCR1AL=0x18;
276 OCR1BH=0x00;
277 OCR1BL=0x00;
```

Whenever the Timer/Counter register value reaches to 3096, it matches with OC1A predefined value that resets the Timer/Counter register value and generates a overflow interrupt. The overflow interrupt service routine is show below.



```

98 // Timer1 output compare A interrupt service routine
99  interrupt [TIM1_COMPA] void timer1_compa_isr(void)
100  {
101 // Place your code here
102     sec++;
103     run_sec = sec;
104     if (sec >= 60)
105     { mins++; sec=0;}
106     if (mins >= 60)
107     { hr++; mins =0;}
108     if(hr>=24)
109     { hr=0; mins=0; sec=0;}
110
111 }

```

The other two 8-bit timer/counters are used to generate glitch free phase-corrected PWM (Pulse Width Modulator). That is used to modulate the power supply given to both heater and cooler depending upon the transition between the stages of the temperatures.

The 8-bit Timer/Counter0 is configured as,

**Timer0 Reference Clock Source : Internal System Clock**

**Prescaler/Clock Divider : 64**

**Mode : Phase Corrected PWM, Top=FFh**

**Output : Non-Inverted PWM**

Since we have used system clock of 4MHz & Prescaler used is 64. Therefore the timer system clock value or the PWM output frequency will be =  $4\text{MHz}/64 = 62500 \text{ Hz}$ .

Since it is 8-bit timer, we can set a maximum value of  $2^8-1$  value, i.e. 255.

Therefore the least ON-time in a cycle of the PWM can be set to  $1/255 = \sim 0.004\%$ .

The smaller the least ON-time, the better we can modulate or control the temperature.

The register configuration of the ATmega32 is shown below.

```

247 // Timer/Counter 0 initialization
248 // Clock source: System Clock
249 // Clock value: 62.500 kHz
250 // Mode: Phase correct PWM top=FFh
251 // OCO output: Non-Inverted PWM
252 TCCR0=0x63;
253 TCNT0=0x00;
254 OCR0=0x00;

```

Similarly 8-bit Timer2 has been used for generating phase corrected PWM for controlling the FAN to help to reduce and maintain the temperature more effectively.

## 5. Human Interface through keypad:

It is the access through three buttons to enter the various parameters according to the choice of user such as time for any stage in seconds (as we know that there are mainly three stages in a PCR machine namely as Denaturation, annealing and Extension), temperature for any stage in °C and to enter the number of cycles as much as the user wants it to run for.

It includes three buttons namely as Enter, Shift and Increment. Enter is used to enter in the program and also for the change in the data saved as in the form of the temperature for the particular stage or the time by using the increment button given which increases the unit digit of the number, Shift is for changing in the digit in which you want to make changes into i.e. decimal or unit number.

Flow chart for the manual interface is given below in fig. 3.4.

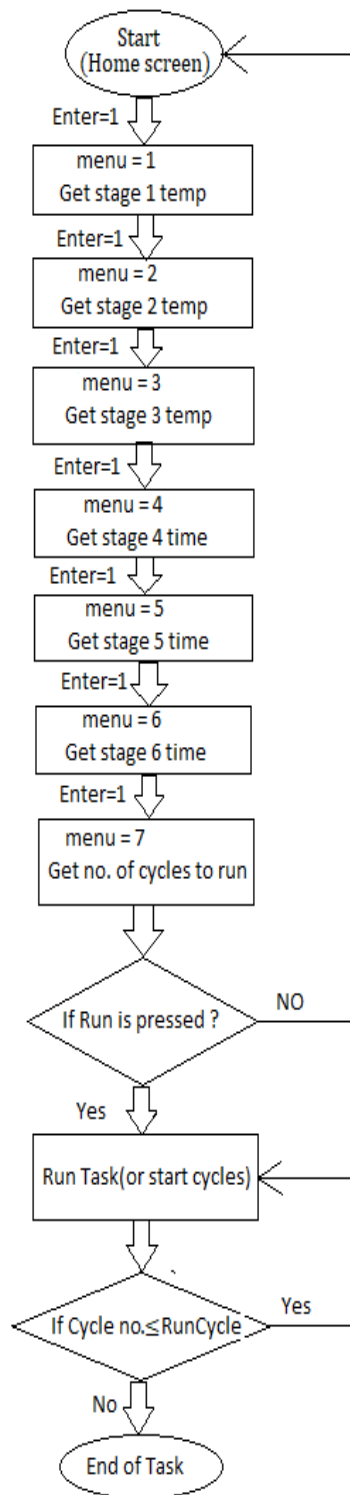

Fig. 3.4: Flow chart for manual interface

## **RUN MODE FIRMWARE ALGORITHM:**

Step1: Measure real-time temperature.

If  $N=1$  and  $\text{run-cycle}=0 \gg$  Reset Time to zero. Start Time.

Display real-time temperature, Stage, Elapsed time and Run-cycle number.

Case 1: If real-time temperature  $<$  StageN set temperature

    Increase duty cycle of the PWM0 to give more power to Heater

Case 2: If real-time temperature  $>$  StageN set temperature

    Decrease duty cycle of the PWM0 (Heater) and Turn-on/Increase the  
    duty cycle of PWM2 (FAN)

Case 3: If real-time temperature  $=$  StageN set temperature

    Do not Change duty cycle of PWM0 or PWM2

If StageN elapsed time  $>$  StageN set time

Then, Increment the Stage by 1. If  $N=4$ , set  $N=1$  & increment run-cycle by 1 to  
loop the run-cycle. Repeat Step1.

If run-cycle = set run-cycles  $\gg$  exit from run-mode, display elapsed time and a  
Message – End-of-Operation

During the Denaturation phase where we are supposed to increase the temperature from the room temperature to  $94^{\circ}\text{C}$  then it is the initial point and the temperature is required to increase between the farthest points so the full load power is given to the heater till the temperature is at  $94^{\circ}\text{C}$ . After the temperature is at  $94^{\circ}\text{C}$  then to maintain the temperature of the sample it uses the pulse width modulation and varies the width of the power according to the temperature maintenance phase.

## **6. Circuit Diagram:**



## 7. Other major components used in the circuit

### 1) Voltage Regulator 7805

Voltage regulator 7805 here is used to get the regulated power supply of 5V after receiving it from the adaptor which is giving a 12V and 1Amp supply. The voltage regulator IC 7805 is actually a member of 78xx series of voltage regulator ICs. It is a fixed linear voltage regulator. The xx present in 78xx represents the value of the fixed output voltage that the particular IC provides. For 7805 IC, it is +5V DC regulated power supply. This regulator IC also adds a provision for a heat sink. The input voltage to this voltage regulator can be up to 35V, and this IC can give a constant 5V for any value of input less than or equal to 35V which is the threshold limit.

Pin Diagram:

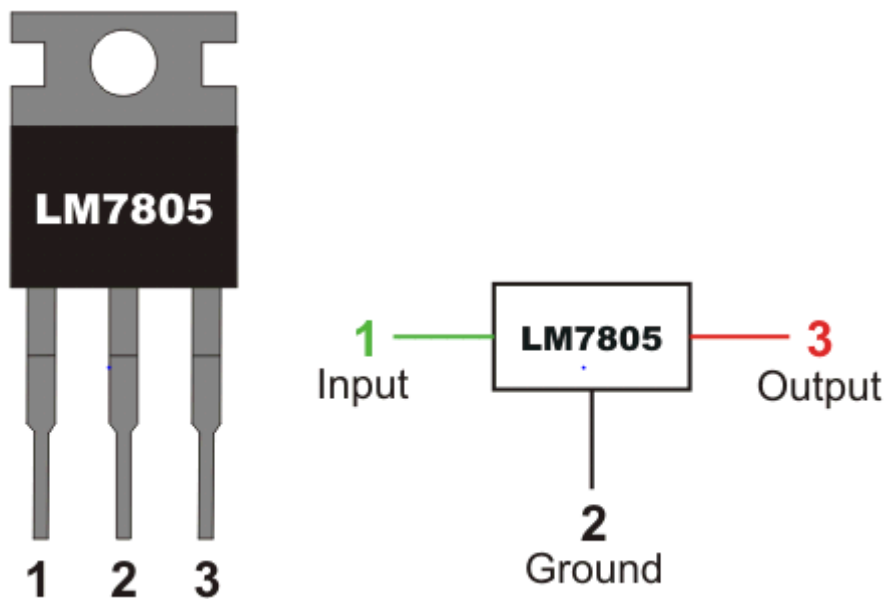

Fig.3.5: Pin diagram

**PIN 1-INPUT** The function of this pin is to give the input voltage. It should be in the range of 7V to 35V. We apply an unregulated voltage to this pin for regulation.

**PIN 2-GROUND** We connect the ground to this pin. For output and input, this pin is equally neutral (0V).

**PIN 3-OUTPUT** This pin is used to take the regulated output. It will be 5 V.

## 2) ZVN2106G E-MOS

The ZVN2106G is a 60V N-channel Enhancement Mode Vertical MOSFET with matte tin plated terminals. The MOSFET is ideal for solenoids/relay driver for automotive and DC-DC converters. Shown in the Fig.2.5 below.

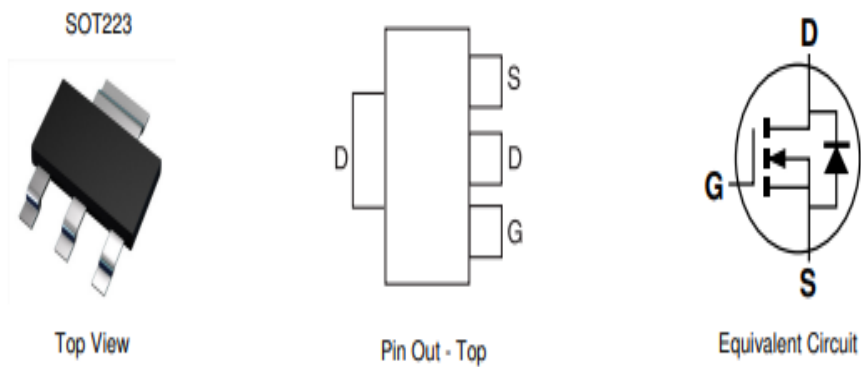

Fig.3.6: Pin diagram of ZVN2106G and equivalent circuit

Absolute Maximum Rating:

Drain-Source Voltage	= 60 V
Continuous Drain Current at T amb	=450 mA
Pulsed Drain Current	=8 A
Gate Source Voltage	= 20V

## 3) PC817 IR LED Optocoupler

PC817 IR LED optically coupled to a phototransistor. This is packaged in a 4pin DIP, available in wide-leads pacing option and SMT gullwing lead-form option. Input-output isolation voltage (rms) is 5.0kV. Collector to emitter voltage is 80V and CTR is 50% to 600% at input current of 5mA.

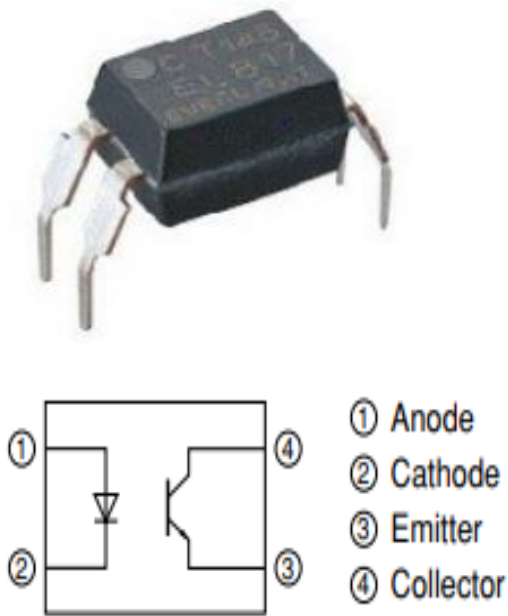

Fig.3.7: Pin diagram of PC817 and equivalent circuit

Features:

1. 4pin DIP package
2. Double transfer mold package (Ideal for Flow Soldering)
3. High collector-emitter voltage ( $V_{CEO}$ :80V (\*))
4. Current transfer ratio (CTR: MIN. 50% at  $I_F=5$  mA,  $V_{CE}=5$ V)
5. Several CTR ranks available

Applications:

1. I/O isolation for MCUs (Micro Controller Units)
2. Noise suppression in switching circuits
3. Signal transmission between circuits of different potentials and impedances



# Chapter 4

## Results and Discussion

### 4.1 Simulation in COMSOL Multiphysics

In this study simulation is of the centrifuge tube of polypropylene material covered with the copper metal sheet up to the height little more than the sample height in the centrifuge tube as shown in the Fig.4.1 below. So that we can handle the fluid expansion in the centrifuge tube on heating the sample.

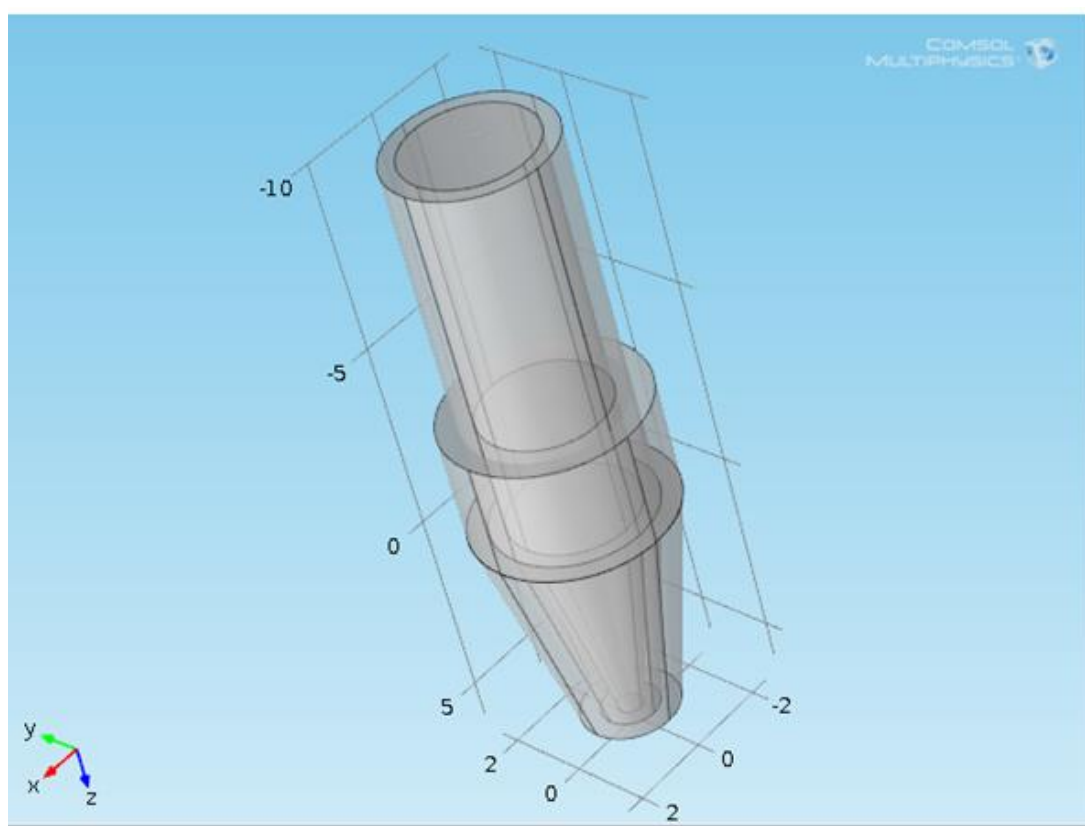

Fig.4.1: Centrifuge tube design in COMSOL

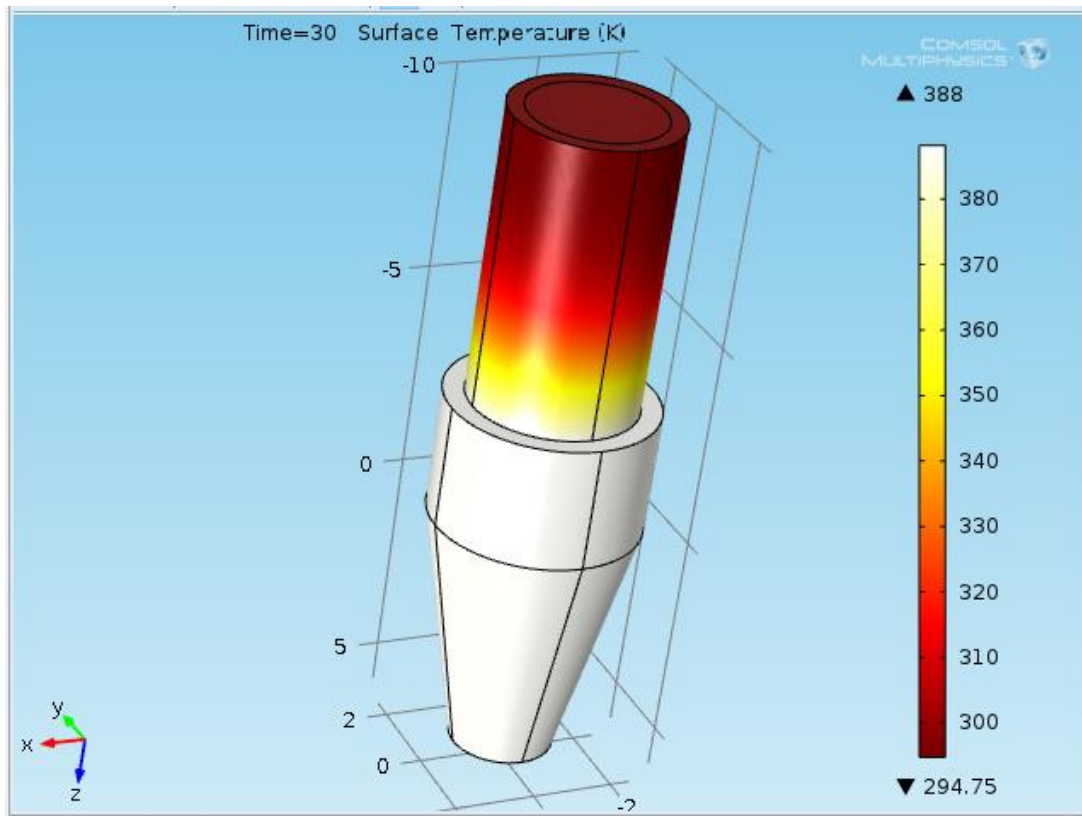

Fig.4.2: Centrifuge tube after heating

We have used water at the place of sample as it resembles the properties closest to the DNA sample. We have heated the outer copper material and observed the time it takes in the time dependent simulation.

The simulation was for the two conditions. First one is in which we have observed that time taken by the temperature  $\sim 94^{\circ}\text{C}$  to reach it to the sample shown in seconds and the result plot can be seen in the Fig.4.2.

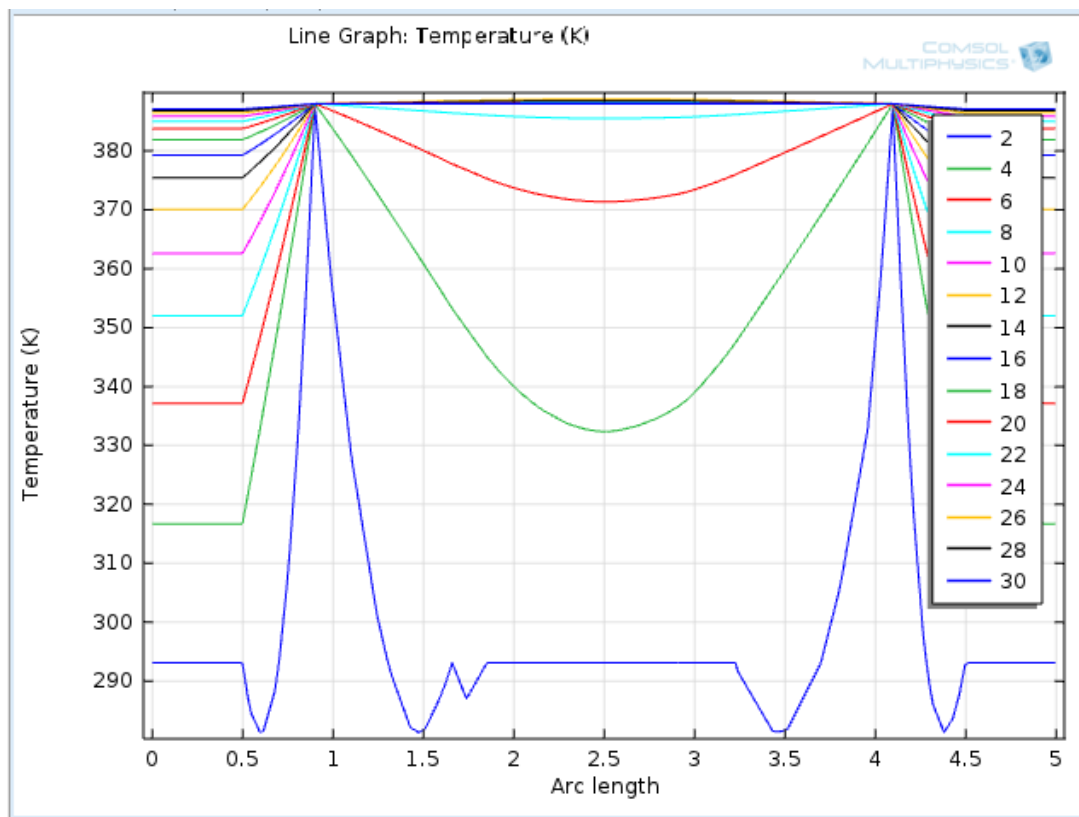

Fig. 4.3: 27°C to 94°C ramp rate

It's been shown in the figure that as the time period increases the temperature of the sample inside the centrifuge tube is increasing. For e.g. blue line is one which shows the spread of the temperature after 2 seconds of application of it at outer copper holder, similarly green is for 4 seconds, red is for 6 seconds and so on. Purple at 10 seconds shows that the temperature has been spread throughout the sample. So 10 seconds is the time sample takes to reach to ~94°C is the result of this simulation.

Second is the one on which we have observed time taken by the sample which it takes to cool down from 94°C to 54°C in seconds and the result plots can be seen in the Fig.4.3.

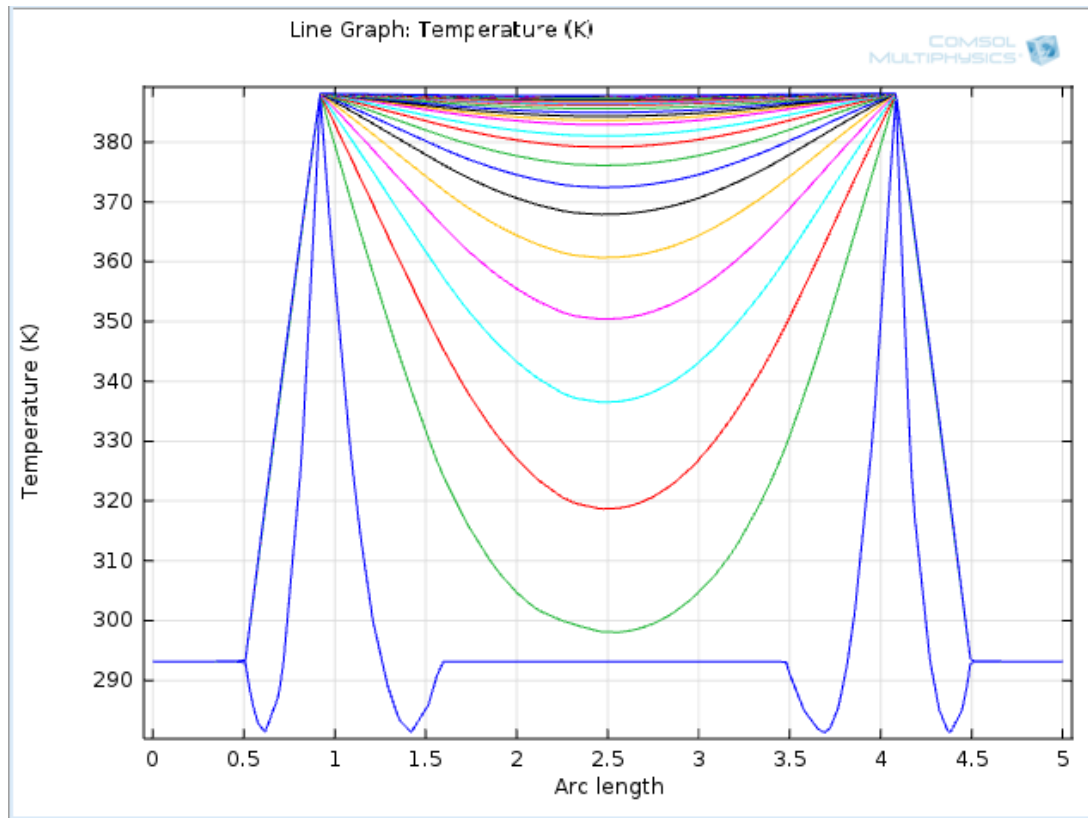

Fig.4.4: 94°C to 54°C ramp rate

As shown in the above Fig.3.3 that there are many plots in which each one is for certain time period. Blue is for 1 seconds and so on followed from the top to bottom. So for the unforceful cooling we can say that it will take nearly 13 or 14 seconds for the sample to cool down from the temp 94°C to 54°C. If we can add some means to cool the sample even faster like a 12V fan of the dimensions 4cm\*4cm then the time it is taking to cool down will come down by a significant amount of time. Further on that point is discussed in the future scope of the thesis.

### Economic Design

The circuit designed by us is economic and works fine with the varying temperature conditions. Its cost of circuit along with the heater section will be around 4000 Indian Rupees while the cost of the conventional PCR is around 2lac Indian Rupees.

Easily transportable because of reduced size

The circuit designed is easily transportable and its size is very less as compared to the existing conventional PCR. As we can see in the Fig4.4 below.



Fig.4.5: Size comparison

# Chapter 5

## Future Scope

Future scope of the project work mentioned in this thesis is to attached the heater and centrifuge tube set along with the circuit designed. A beautiful combination can come up by clubbing together since the designed circuit is made to complement the heater and centrifuge set. It can be seen together in the fig.4.1 below in the block diagram form.

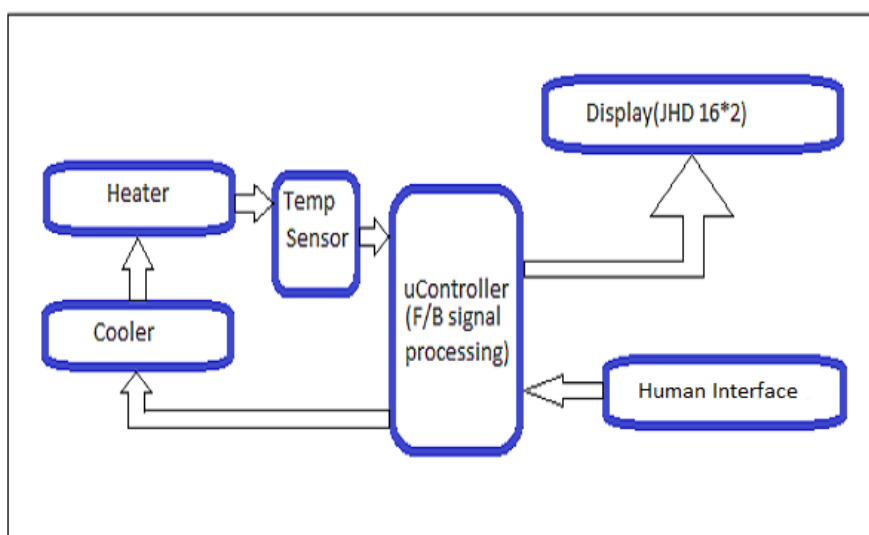

Fig.4.1: Block diagram with heater part

From the above diagram we can see that the heater along with the cooler is completing a close loop which is making it a close loop circuit so it will improve the accuracy of the circuit by getting the feedback in the real time.

Heater section along with the centrifuge tube can be seen in the three dimensional fig.4.2 below.

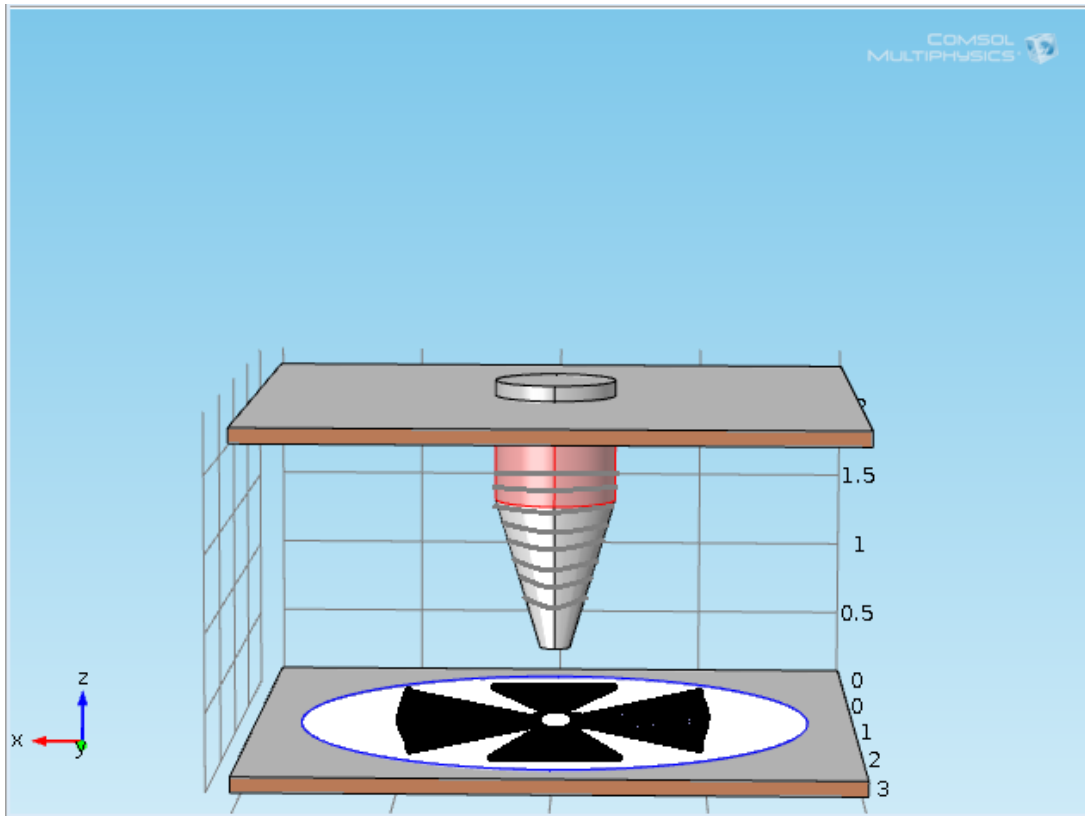

Fig.4.2: heater section with centrifuge tube

As seen the combination of the heater section with cooler and centrifuge tube from the figure.

#### 4.1 Centrifuge tube:

Centrifuge tube used here is made up of the polypropylene material. These are the below some qualities of the centrifuge tube

- 1) Stable under high centrifuge speed, up to 15000 rpm.
- 2) It can guarantee staff safety and environment while testing toxic samples.
- 3) Adapted to wide range of temperature from -80 C to 121 C, no distortion.
- 4) Clear graduation on the wall for easier observation.
- 5) Frosted area on the cap and tube for come vent mark and identification.

Made of High transparency PP material, adapted to micro centrifuge, widely used in molecular biology, clinical chemistry and Bio-chemistry research. The cap can be one-hand open and closed, Easy to operate. Chemical corrosion and low temperature resistance. No release reagent, plasticizer and fungi state added during production, free of heavy metal.

#### 4.2. Holding sheets

Holding sheets can be of some material as fiber with one sided coated with copper material so that temperature can be dispersed easily. And its material can be helpful in keeping the setup light weight and economic. Upper sheet which is to hold the centrifuge tube should be placed such that the copper coated side of the sheet is on down side. Other sheet which is below is to attached the fan of 12V or 5V can be chosen. Dimensions of the sheets are 4cm\*4cm. Such dimensions are selected for the sheets to serve the purpose to attach the fan which is of the same dimensions which is 4cm\*4cm.

#### 4.3. Nichrome (or Kanthal) wire as heater

Nichrome wire will be used to surround the copper cap of the centrifuge tube. Nichrome wire of the different dimensions are available in the market but most commonly used Nichrome wire is of size 24SWG. It is good to use as a heater but it takes more power to heat up so what we can do is we can use the Nichrome wire of 37AWG so that it has enough resistance to get heated up by the 9V battery.

#### 4.4. Copper cap

Copper cap or copper holder of the 5mm wall thickness can be used. That cap will help the heater to disperse the temperature with faster rate and uniformly. Copper cap can be made by molding.

#### 4.5. Fan

The fan will help in cooling the sample with much faster rate. Here the fan is of 5V can be used. The fan will not work effectively if our heater setup is open but if can cover it with aluminum foil or somehow then what we will get the concentrated air flow mostly touching the wall of the copper cap and that will make the fan working more effective.

#### 4.6. Make circuit work with battery

It is the ultimate future scope for the project to make it work with the 9V battery so that it can work without supply. Working the whole circuit with the 9V battery will make the circuit supply independent and transportable so that it can be used in the remote places like in the village hospitals to detect the presence of virus.



# References

- [1] Lagally, E. T., et al. "Integrated portable genetic analysis microsystem for pathogen/infectious disease detection." *Analytical chemistry* 76.11 (2004): 3162-3170.
- [2] Walczak, R., et al. "Miniaturized real-time PCR system: toward smart diagnostic device for point-of-care food pathogens DNA analyze." *Mixed Design of Integrated Circuits and Systems, 2008. MIXDES 2008. 15th International Conference on. IEEE, 2008.*
- [3] Miralles, Vincent, et al. "A review of heating and temperature control in microfluidic systems: techniques and applications." *Diagnostics* 3.1 (2013): 33-67.
- [4] Texas Instruments – AVR ® ATmega32 8bit Microcontroller IC
- [5] Wiki – School of Bio-medical Sciences  
<https://teaching.ncl.ac.uk/bms/wiki/index.php/DNTP>
- [6] Texas Instruments – LM35 Precision Centigrade Temperature Sensors

