

**NOVEL DESIGN AND ARCHITECTURE DEVELOPMENT OF
FIXED AND VARIABLE FOCAL LENGTH BEAMFORMING
CIRCUITS FOR ULTRASOUND SCANNERS**

P UDAYA TEJA

A Dissertation Submitted to
Indian Institute of Technology Hyderabad
In Partial Fulfillment of the Requirements for
The Degree of Master of Technology



भारतीय प्रौद्योगिकी संस्थान हैदराबाद
Indian Institute of Technology Hyderabad

Department of Electrical Engineering

June, 2016

Declaration

I declare that this written submission represents my ideas in my own words, and where others' ideas or words have been included, I have adequately cited and referenced the original sources. I also declare that I have adhered to all principles of academic honesty and integrity and have not misrepresented or fabricated or falsified any idea/data/fact/source in my submission. I understand that any violation of the above will be a cause for disciplinary action by the Institute and can also evoke penal action from the sources that have thus not been properly cited, or from whom proper permission has not been taken when needed.



P UDAYA TEJA
EE14MTECH11020

Approval Sheet

This thesis entitled **Novel Design and Architecture Development of Fixed and Variable Focal Length Beamforming Circuits for Ultrasound Scanners** – by **P Udaya Teja** is approved for the degree of Master of Technology/ Doctor of Philosophy from IIT Hyderabad.



Dr. GVV Sharma

- Department of Electrical Engineering
Examiner



Dr. Sri Rama Murty Kodukula

- Department of Electrical Engineering
Examiner

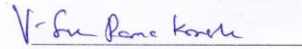

- Dr. Siva Rama Krishna Vanjari

- Department of Electrical Engineering
Adviser



Dr. Pankaj Kolhe

- Department of Mechanical Aero Space Engineering
Chairman
-

Acknowledgements

I would like to express my sincere gratitude to my supervisor **Dr. Siva Rama Krishna Vanjari**, for the continuous support of my Master's study, and his guidance throughout this thesis. My sincere thanks also goes to my colleagues especially Jose Joseph, Bastin Joseph for their suggestions and for all the fruitful discussions that enhanced this work.

I would like to give thanks to my parents, Rama Surya Narayana and Lakshmi kantham, who encouraged me so much in life and helped me become the person I am today.

Dedicated to

My beloved Parents and my lovely Brother.

Abstract

Real-time ultrasonic imaging systems have been available for more than sixty years and are becoming an important tool in the practice of modern medicine. There are a lot of improvements occurred to the basic architecture and functions of these clinical systems and their beamformers, which are, in many ways, the most important components of these systems. In this thesis we proposed various Ultrasound Beamforming techniques that are used in biomedical applications, Beamforming circuits are used to steer the ultrasound waves to focus at desired location. Our main importance is to design and architecture development of low power and area efficient beamforming circuits. CMUT is used as transducer element is our beamforming approach which has better impedance matching with the medium, high sensitivity, low power consumption, high bandwidth when compared to conventional piezoelectric transducer elements which are usually used in ultrasound scanners. The proposed beamforming techniques in this thesis are square root architecture, LUT architecture, dual angle architecture. From LUT based architecture we can achieve better results in terms of area and power compared to the square root architecture and from dual angle architecture we get the flexibility of Varying the focal length which helps in scanning various parts of the body which the same device.

Contents

Declaration.....	ii
Approval Sheet.....	iii
Acknowledgements.....	iv
Abstract.....	vi
Chapter 1 Introduction.....	1
1.1 Ultrasound.....	1
1.2 Ultrasound Imaging.....	2
1.2.1 Examples of Ultrasound imaging.....	2
1.3 Beamforming	5
1.4 Overview of Thesis.....	7
Chapter 2 Literature Study.....	9
2.1 2D Imaging Transducers.....	9
2.2 3D Imaging Transducers	11
2.3 CMUT Transducer	13
Chapter 3 Square Root Architecture	15
3.1 Square Root Model Outline	15
3.2 Distance Computation of array elements to focal point	15
Chapter 4 LUT Architecture based Beam Forming logic	19
4.1 LUT Model	19

Chapter 5 Dual Angle Beamforming Architecture.....	23
5.1 Outline.....	23
5.2 Dual angle Approach	23
Chapter 6 Variable Focal Length Beamforming Technique.....	27
6.1 Variable focal length approach	27
Chapter 7 Literature study and Future Work	31
7.1 Ultrasound Receiver	31
Chapter 8 Conclusions	34
References.....	35

Chapter 1

INTRODUCTION

1.1 Ultrasound

Sound waves that span in frequency range higher than upper audible limit is termed as ultrasound. The ultrasound frequency is ranging from 20 kHz to few GHz. Ultrasound finds many applications in day to day life. Medical imaging is one of the most important applications of ultrasound. The low frequency ultrasound waves are used to image deeper features of human body, but the resolution they provide will be poor. Higher frequency ultrasound provide better quality images, but are readily absorbed by the skin and other tissue, so they cannot penetrate as deeply as lower frequencies. Hence high frequency ultrasound is employed to image superficial features [1].

The following are the other important applications of ultrasound. Ultrasonic devices are used to detect objects and measure distances. Ultrasound finds is application in non-destructive imaging of products and structures to detect the invisible flaws. The industrial applications of ultrasound include cleaning, mixing and accelerating chemical processes. Animals such as bats and porpoises use ultrasound for locating prey and obstacles. Scientists are also studying ultrasound using graphene diaphragms as a method of communication. In this Thesis we mainly consider ultrasound in biomedical applications.

Diagnostic ultrasound "Ultrasound ranging from 1MHz to 10 MHz are been specifically used for medical purposes [2]."

Therapeutic ultrasound "Ultrasound having higher intensity causes coagulation necrosis of tissue, used in treatment of tumors [2]."

1.2 Ultrasound Imaging

Ultrasound imaging or sonography is an imaging technique which is used to scan the human's heart, kidneys, lungs, liver, fetus etc. It is an inexpensive, fast and radiation-free imaging method. When Ultrasound waves travelling in same direction we can observe the interference pattern forming, when waves are in phase we can observe constructive interference and when they are in out of phase we can see destructive interference. Focusing of ultrasound waves to get constructive interference at the focal point is the main principle involved in ultrasound imaging.

Ultrasound imaging is used in diagnosing process of human organs. Recent trends in ultrasound imaging techniques help in guiding during pregnancy and child birth. We can observe the fetal growth and body functions urination, breathing etc. using ultrasound imaging. Doctors examine the liver, kidneys, heart, pancreas, and blood vessels of the neck and abdomen using ultrasound process, cancer tissues can also be detected [2,3,11].

Ultrasound imaging plays a crucial role in the detection, diagnosis and treatment of heart disease, acute stroke, heart attack and vascular disease which leads to heart stroke, Ultrasound guides the doctors in treating the breast cancer.

Safety of Ultrasound Imaging

As ultrasound waves are a just sound wave which doesn't have any negative effects on human body. But the prolonged scan may heat up the transducer and in turn may cause discomfort to the patient. Usually prolonged scanning of fetus is not recommended.

1.2.1 Examples of Ultrasound Imaging

Obstetric Ultrasonography

The medical ultrasonography which helps in creating visual images of developing fetus in mother's womb is called obstetric ultrasonography. The timing and progress of the pregnancy and Health of the mother can be monitored using obstetric ultrasonography [2]. Ultrasound scanning images of fetus at different stages is shown in fig. 1.1.



Fig. 1.1 Photo left: ultrasound of a fetus at 22 weeks. Photo right: little big feet in the uterus at 18 Weeks [2].

Transducer is placed on abdomen of pregnant woman to do obstetric ultrasound imaging. Transvaginal sonogram is one of the variant of obstetric sonography which is done by placing the probe in woman's vagina, using this sonogram we get the visual pictures of early stages of pregnancy. The other variant is Doppler sonography detects the heartbeat of the embryo or fetus and helps to evaluate the pulsations in embryo heart and blood vessels for any sign of abnormalities.

Cardiovascular sonography

Cardiovascular sonography also called known as Echocardiography which uses ultrasound waves to get visual images of heart's walls, valves, chambers and vessels. Cardiac sonographers are the one who examine the heart's condition from visual images obtained from cardiovascular sonography [2]. Ultrasound image of a human heart is shown in fig. 1.2. From the visual images obtained from cardiovascular sonography, physician can do following tasks such as

- (i) Evaluation of leaking heart valves
- (ii) Evaluation of chronic heart conditions
- (iii) Diagnosing cardiovascular diseases

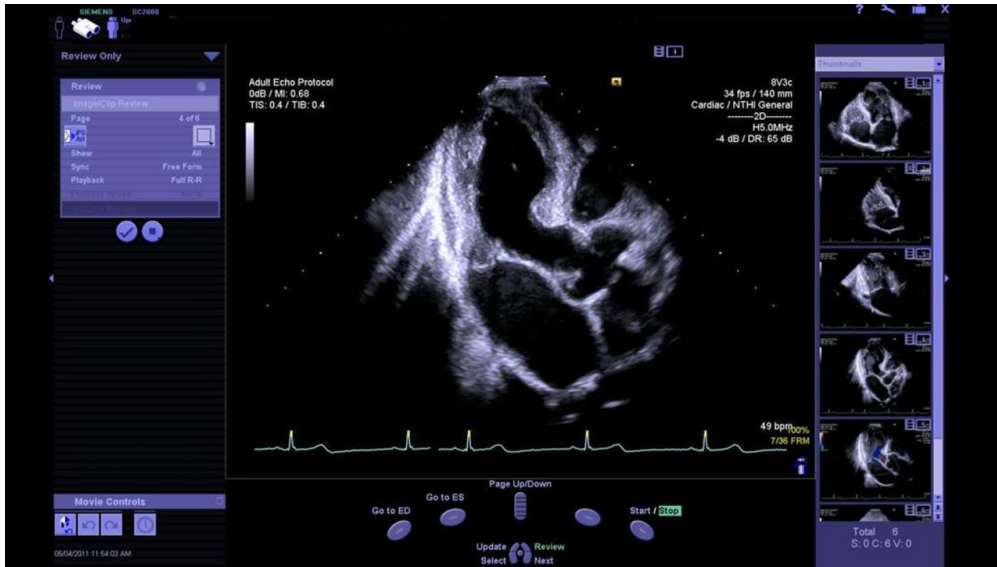

Fig. 1.2 ultrasound imaging of heart [2]

- (iv) Information of heart's anatomy and physiology
- (v) Evaluation of congenital cardiac abnormalities and associated complications

Abdominal Sonography (gastroenterology)

Abdominal ultrasonography uses ultrasound waves to get the visual images of abdominal anatomical structures. Gel is placed on the abdomen for ultrasound waves to pass through. The Abdominal sonography helps the healthcare professional in the diagnosing process of internal organs such as liver, spleen, kidneys, bile ducts, gall bladder, aorta, inferior vena cava, pancreas and other solid organs located in the abdomen. Kidney stones can be clearly visualized and helps physician in diagnosis using abdominal ultrasound imaging [2]. One such abdominal sonographic image is shown in fig. 1.3.

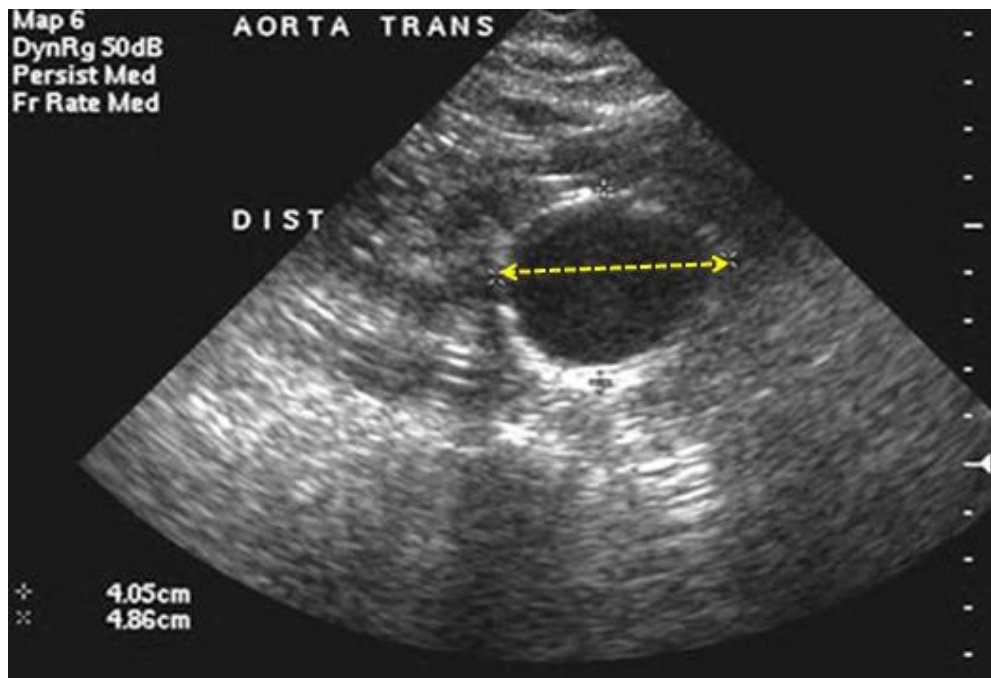

Fig. 1.3 Abdominal Ultrasound Imaging [2]

Ultrasound in neurology

Ultrasound waves are used to measure blood flow in the carotid arteries. This technique is known as carotid Ultrasonography, which helps to find out blood clots and atherosclerotic plaque build-up. A carotid duplex is a form of carotid ultrasonography using Duplex ultrasonography, this includes Doppler ultrasound test which reveals how blood cells move through the carotid arteries [2].

1.3 Beamforming

Beamforming is nothing but controlling the interference pattern such that amplification of interference pattern occurs predominately in the focused direction. It is the technique used in transducer arrays for signal spatial directivity in transmission as well as reception.

The ultrasound signals from the transmitting transducers are steered such that the amplitude and phase of individual array elements are controlled to form constructive interference or destructive interference. The resulting wave front will have the energy concentrated in the desired direction [3, 4]. Beamforming is also used in the receiving mode to form the image by combining the echoes from the sample which was received at the transducer elements.

There are generally two kinds of beamforming techniques; static and adaptive. Static beamforming technique involves using some fixed set of parameters for the transducer array. In static beamforming, the individual gain and phase of each element is dictated only by its geometry and the static directionality requirements of its application. On the other hand adaptive beamforming technique can adapt the parameters of the array in accordance with changes in the situation in which the array is immersed. Adaptive beamforming technique can perform substantially better in cases such as noise rejection; however, since adaptive beamforming is computationally demanding it is not worth implementing in applications with lower requirements.

The Ultrasound transducer arrays which make use of beamforming techniques are also known as phased arrays. The phased array can also be classified in two categories time domain and frequency domain beamforming [4, 6]. Time domain beamforming technique is based on sum and delay operations, delaying the ultrasound signal from each array element by a certain amount of time and then adding them. Other operations such as multiplication are also employed during this procedure in order to highlight the desired wave patterns or to insert zeroes and therefore perform filtering.

Frequency beamforming technique decomposes the incoming signal into frequency bands; generally two different techniques can perform this separation, Fast Fourier Transforms, or multiple filter banks. After the signal is decomposed in different frequency bands time domain beamforming is then applied to each individual bands. This technique allows the phased array to have different directivity toward different frequencies. Both kinds of beamforming algorithms can be employed either with static or adaptive beamforming [6].

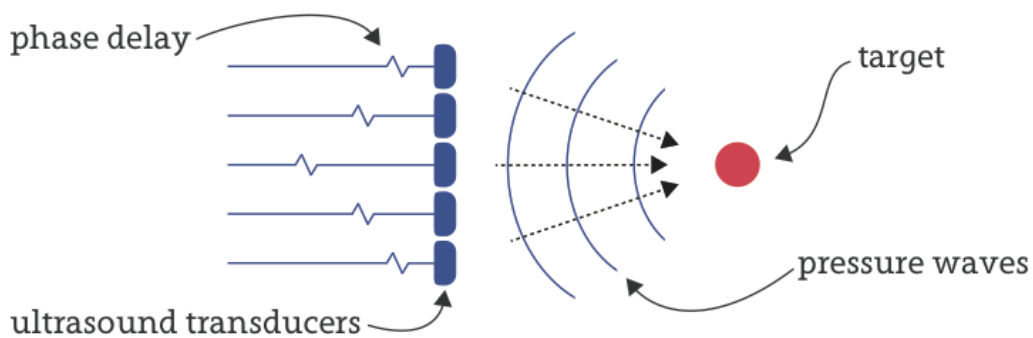

Fig. 1.4 Beamforming Technique [6]

1.4 Overview of Thesis

Chapter 2 Provides information on 2D and 3D imaging transducers, structure and advantages of using transducer element capacitive micromachined ultrasound transducer (CMUT)

Chapter 3 Explains the implementation of Square Root architecture based Beamforming, shows area and power results of square root model.

Chapter 4 Explains the implementation of LUT architecture based Beamforming, shows area and power results of LUT model.

Chapter 5 Explains the architecture of Dual angle based Beamforming, shows area and power results of Dual angle Beamforming logic.

Chapter 6 Explains the advantages and implementation of variable focal length based Beamforming Technique, shows area and power results variable focal length approach.

Chapter 7 Provides the information on design of ultrasound receiver.

Chapter 8 Conclusions.

Chapter 2

Literature Study

2.1 2D Imaging Transducers

Transducers arrays employ a variety of structural arrangements. The typical arrangements used for 2D imaging transducers are linear arrays, phased arrays, and annular arrays [5].

Linear Array

In Linear array arrangement, the long strip of elements are been separated with the separation distance of full wavelength. All the elements are divided into groups such that each group contains equal number of elements. Each sub group of elements is dedicated in order to produce a single transmission line. Since the separation between the elements is full wavelength, to avoid the grating lobes they are not steered off the axis. To achieve fan beam kind of structure, the elements are typically arranged in the form of curve [6, 10, 12]. A linear array arrangement is shown in in fig. 2.1

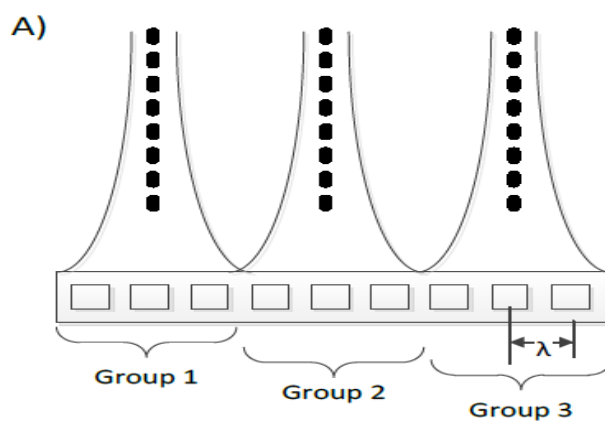

Fig 2.1(a) Linear Array elements [10]

The linear array channels share the transmitting and receiving channels. It is also useful to notice that the symmetry of the image region changes for a linear array, by producing image lines that are orthogonal to the transducer surface. For each line of image the transmitting and receiving delay patterns of beamforming are the same.

Phased Array

A phased array of arrangement is shown in Figure 2.2. A strip of rectangular transducer elements are used in order to produce a beam in phased array. The strip elements are arranged such that they are spaced at half a wavelength separation (or less). This kind of spacing allows the off-axis beam steering without inducing any grating lobes into the field. This is how the phased array is used [6,12]. The image is made up from image lines that are spread from the array over a range of angles, forming from the familiar arc sector shape. Each line in the image is usually a separate transmission focused along an image line.

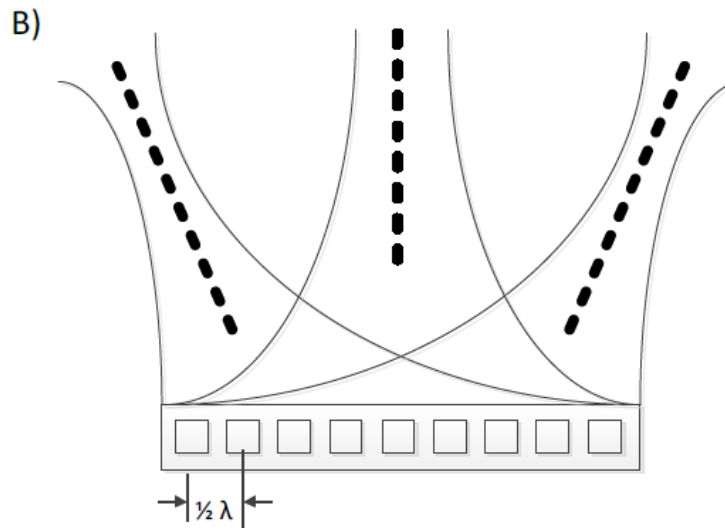

Fig 2.1(b) Phase array [10]

Annular Array

Ring shaped transducer elements are used in the arrangement of annular array as shown in the fig. 2.1(c)., usually defined with constant area rather than constant width. This kind of arrangement of transducer elements helps to control the transmit focal depth, as well as receive focus beamforming [6].

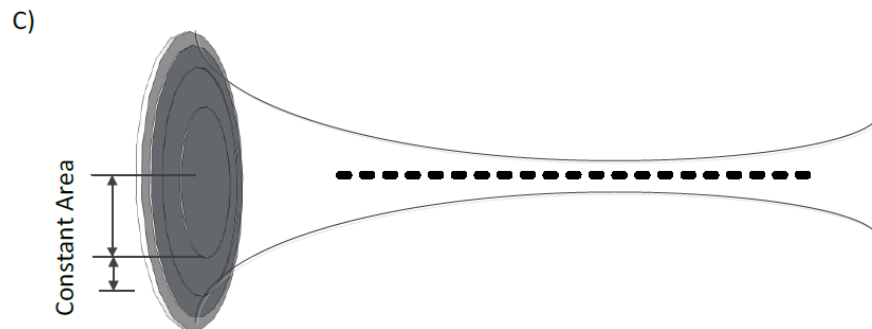

Fig 2.1(c) Annular Array [10]

Since the transducer elements are circularly shaped so electrical beam steering is not possible but some form of mechanical articulation is necessary to form an image. The advantage of using circular arrangement of elements is that the beam formed is symmetrical in nature and can be focused in a 3D volume. In addition to these advantages annular arrays just require fewer elements to produce a required radiation pattern.

2.2 3D Imaging Transducers

So far all discussions have been restricted to two dimensions, however in reality all transmitted waves are propagating in three-dimensions. For linear array transducers, the elevation direction (which is the direction perpendicular to the image plane) information is undesired, and energy is typically focused in this dimension using a fixed focus acoustic lens [9]. An acoustic lens operates by using the variation in acoustic impedance between itself and the imaged medium in order to bend the transducer's sound waves to form a fixed focus. The operation of an acoustic lens is demonstrated pictorially in Figure 2.2(a,b)

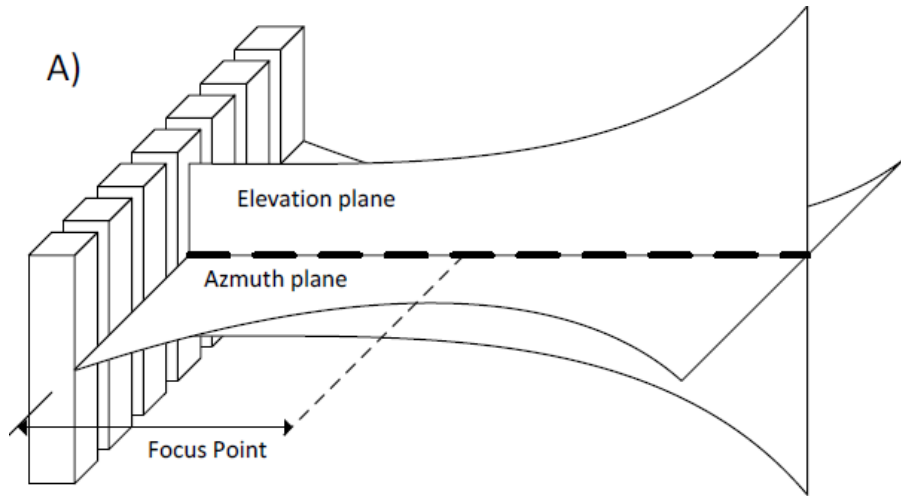

Fig 2.2(a) Propagation of ultrasound waves in the elevation direction for an unconstrained array [9]

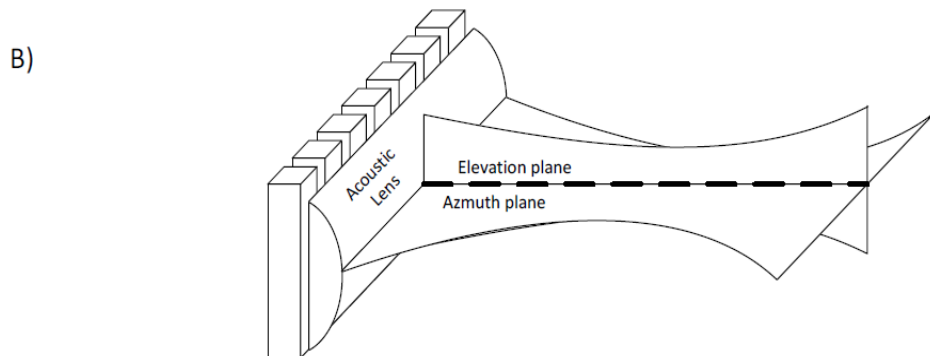

Fig 2.2(b) Propagation of ultrasound waves in the elevation direction for an array using an acoustic lens [9]

While an acoustic lens can significantly reduce the image slice thickness, it also introduces the same limitations discussed for fixed focus transducers. The design also cannot create a three dimensional scan volume without modification[9].

2.3 CMUT Transducer

Most of the Ultrasound sensors are made using piezoelectric transducer elements. Though they have good working frequency and high output pressure to provide good image quality, they lack proper coupling of acoustic waves from transducer to specimen and vice versa, due to the acoustic impedance mismatch between the transducer and specimen. The fabrication of piezoelectric transducers is also challenging when we downscale the dimensions as the deposition of piezoelectric material at such small scale is difficult [13].

The Capacitive Micromachined ultrasonic transducers (CMUT) have been developed in recent years to acts as alternative to piezoelectric transducers. It produces ultrasound waves through mechanical vibrations of a membrane separated with a gap from the substrate. The membrane is triggered electrostatically by electrodes embedded in its structure.

Capacitive Micromachined Ultrasonic Transducer (CMUT) is a promising MEMS device that can potentially replace the power consuming piezoelectric transducers as it having advantages like better impedance matching with the medium, CMOS integration, better dynamic range, high sensitivity, low power consumption, high bandwidth etc. CMUT is basically a parallel plate capacitor with air/vacuum as dielectric. The upper plate is a thin membrane made of the appropriate material to achieve desired figures of merit. The basic unit is termed as a cell and the collection of cells that are clocked together forms an element and the combination of independent elements form a CMUT array, which generates ultrasound waves upon excitation. The ultrasound waves are steered to focus at a particular point by beamforming technique [13-15].



Fig. 2.3 Schematic of a CMUT cell [13]

A CMUT consists of a pair of electrodes as shown in the fig 2.3 one electrode at the top and the other electrode at the bottom. The bottom electrode is typically not movable and situated on top of a substrate and the top electrode, on the other hand, sits on top of a movable membrane. The electrodes are separated by a gap or cavity, of air or vacuum, allowing room

for the membrane to vibrate upon vibration ultrasound waves gets generated. Whenever a bias voltage, typically several tens of volts is applied across the electrode, electrostatic force gets developed which pulls the top electrode down and reduces the gap height [16, 17]. To generate ultrasound, a voltage pulse is applied across the biased device. The pulse causes the top electrode to vibrate at the resonant frequency of the structure, resulting in ultrasound waves. The same CMUT can also be used to detect ultrasonic waves. There would be change in capacitance between the electrodes whenever incoming ultrasound waves cause the top electrode to move. Having the bias voltage fixed, a current corresponding to the incoming ultrasound pressure can then be measured [18]. An ultrasonic transducer consists of many CMUT cells connected in parallel in order to generate enough power. In addition to that for ultrasound imaging applications, an array of transducer elements is typically required.

Chapter 3

Square Root Architecture

3.1 square root model outline

In this chapter square root architecture model of beamforming is been implemented. This is the conventional model of beamforming logic. This is implemented to compare the performance of the other novel algorithms proposed. The square root model consists of the following modules in its architecture.

- (i) Square root module
- (ii) Multiplier module
- (iii) Adder Module
- (iv) Cordic Module to calculate the consine values

3.2 Distance Computation of array elements to Focal Point

Fig. 3.1 shows the geometric computaion diagram for square root based architecture. Let us consider P be the focal point i.e, the point where we want to focus and R_{fp} is focal length i.e distance from centre of the array to the focal point.

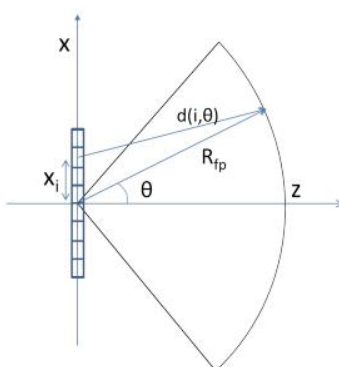

Fig 3.1 Geometric Computation of distance between array elements to Focal Point [19]

The distance from focal point to array elements are different for different array elements, to focus at particular point the array element farther from focal point should be clocked first and the element nearer to the focal point should be clocked last[7].

Where x_i is the distance of the i^{th} CMUT element from the center of the transducer array

The distance from array element to focal point at an angle θ is given by [19]

$$d(i, \theta) = \sqrt{R_{fp}^2 + x_i^2 - 2x_i R_{fp} \sin\theta}$$

Where x_i is the distance of the i^{th} CMUT element from the center of the transducer array. θ is the angle made by the line joining the center of the array to the focal point and the horizontal axis. Time required for the ultrasound to propagate from element i to the focal point at θ can be computed as

$$t(i, \theta) = d(i, \theta)/v$$

Where v is the velocity of ultrasound in the medium. The transducer element farthest from the focal point should be clocked first as it takes maximum time ($t_{\text{MAX}} = \max(t(i, \theta))$) for the generated pulse to reach the focal point. Hence the time delay for each element can be computed with respect to the farthest element.

$$t_d(i, \theta) = t_{\text{MAX}} - t(i, \theta)$$

These time delays should be expressed as multiples of the clock period of the beamforming circuit.

$$t_d(i, \theta) = n(i, \theta) * T$$

Where T is the clock period after computing the values of $n(i, \theta)$, sound waves from different elements can be delayed in compliance with these values. The precision of delay for the transducer elements depend on clock period. Smaller the clock period, better is the precision.

Each CMUT element is triggered according to the respective delay value calculated. All the CMUT array elements are triggered according to their respective delay values to focus at desired point.

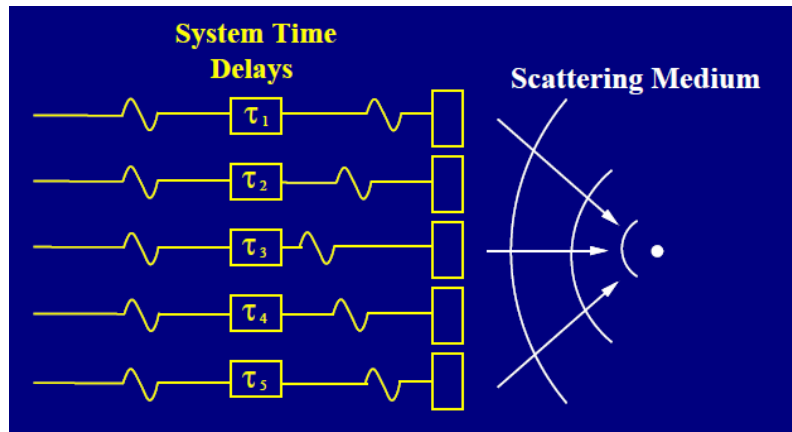

Fig. 3.2 showing time delays to be triggered for respective CMUT elements [put reference]

The Beamforming circuits are implemented by targeting Application Specific Integrated Circuit (ASIC) platform at Vdd 1.62V for UMC 180nm technology. The power and area analysis are done using Synopsys DC Compiler Tool and Backend part of the design is done using Synopsys IC Compiler Tool. The RTL coding of the design is done using Xilinx ISE 14.1, and RTL and netlist verification is done using Synopsys Formality Tool. The Square Root Architectural model involves following modules Multiplier module, Square Root Module and Cordic Module, area and power reports of these modules are shown below

Table 3.1 showing area & power reports of multiplier, divider, cordic modules

Modules	Area Report(um2)	Power Report(mw)
Multiplier	2318.6	0.8093
Divider	1600	0.5379
Cos angle	49694	0.8644

Table 3.2 showing area & power reports of complete module

Modules	Area Report(um2)	Power Report(mw)
8 array elements	118645.5	3.15
16 array elements	138225.5	4.01
32 array elements	168814.1	5.66

The simulation results of the delays calculated for 8 array elements in Xilinx ISE 14.1 are shown in below fig.

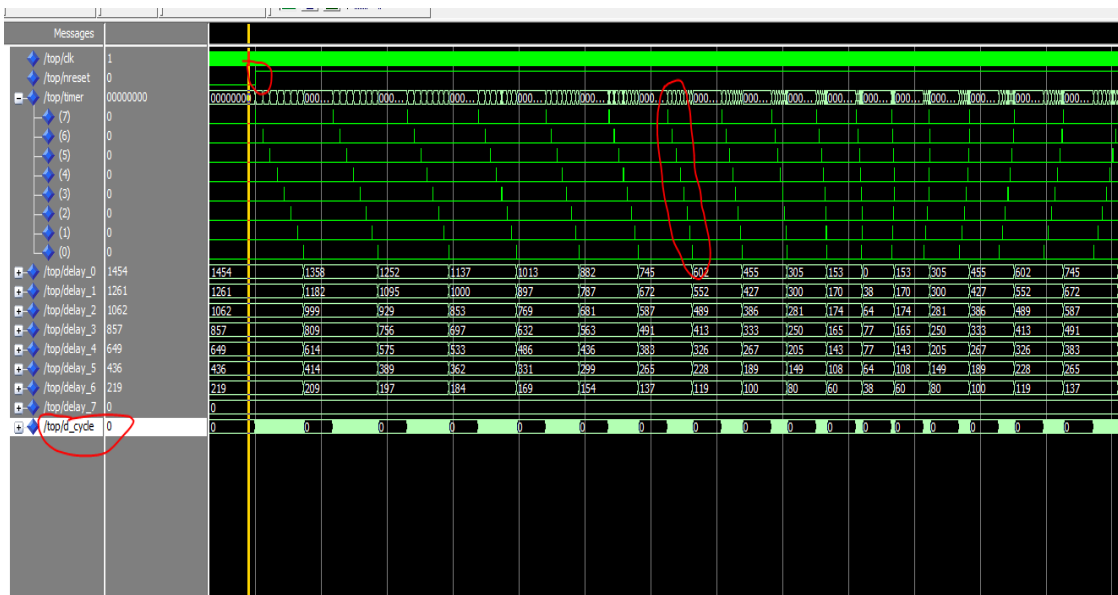

Fig 3.3 simulation results of delays of 8 array elements

Chapter 4

LUT Architecture based Beamforming logic

4.1 LUT Model

As we have seen in the square root model the power and area reports obtained are very high, in order to get better results we go for LUT based approach.

LUT based architecture consists of following modules in its design

- (i) LUT
- (ii) Counter
- (iii) Control Block

The Look up Table (LUT) based architecture stores the pre-computed delay values for each element at all focal points [19]. The delay numbers are integral multiples of clock cycles. Upon the initiation of focusing process at a particular focal point, the delay values have to be compared with the number of elapsed clock cycles. Once the delay value of an element in the array matches with the elapsed clock cycles, the triggering pulse is provided to the corresponding element [19].

Counting the number of clock cycles elapsed is taken care by the counter block in the architecture. The comparison of delay values with the elapsed clock cycles is a parallel process i.e it is carried out for all the elements in the array simultaneously. The comparison and subsequent pulse triggering actions are carried out by the control block. The control block takes the counter output and the LUT data as input and gives the delayed pulses as the output [19].

In LUT Based Architecture the components that are present are less compared to the SQRT architecture and the number of computations that are been taking place are also less this helps in reducing the power an area. The Control Block consists of comparator which

compares the value from LUT block to the counter whenever both matches it generates the output high pulse to trigger the respective CMUT array element. LUT Based architecture is shown below

The design is implemented by targeting Application Specific Integrated Circuit (ASIC) platform at Vdd 1.62V for UMC 180nm technology. The power and area analysis are done using Synopsys DC Compiler Tool and Backend part of the design is done using Synopsys IC Compiler Tool. The RTL coding of the design is done using Xilinx ISE 14.1, and RTL and netlist verification is done using Synopsys Formality Tool.

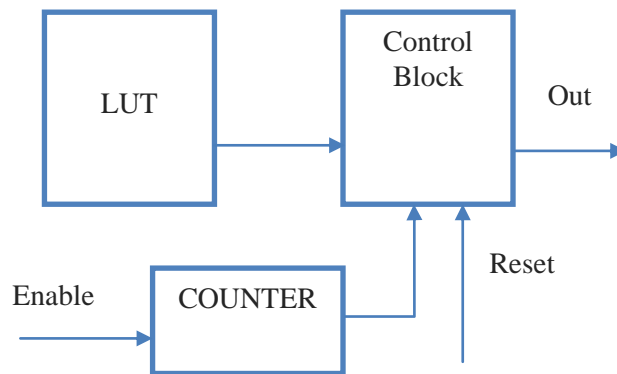

Fig. 4.1 LUT Based Beam Forming Architecture for fixed focal length

The LUT based approach gives reduced area and power results when compared to the square root based architecture. The power and area results for LUT Based approach are shown below

Tab 4.1 showing area and power reports of LUT based architecture based approach for fixed focal length

Modules	Area Report(um2)	Power Report(mw)
8 array elements	7540.1	0.27
16 array elements	13920.9	0.41
32 array elements	26357.6	0.68

The Tabular form shows the 8 array elements occupy less area and consume less power when compared to the higher array elements this is because 8 array elements have less number of delay values to be in stored in LUT the LUT size of 8 array elements is less compared to the other higher array elements and the number of comparisons of delay values and the counter values done by control unit are very less compared to the other array elements, this proves the point that why 8 array elements occupy less area and consume less power.

The simulation results of 16 array elements in Xilinx ISE 14.1 are shown in below fig.

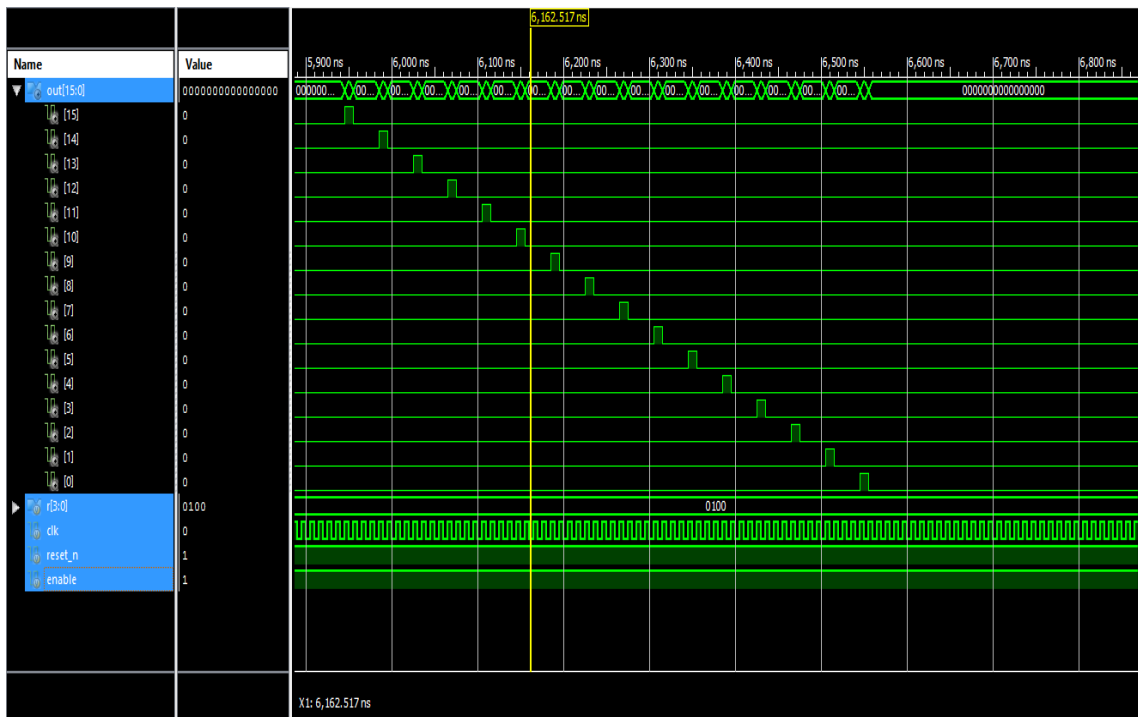

Fig 4.2 simulation results of 16 array elements

The simulation results shows that the CMUT element which is far away from the focal point is triggered first in the above case it is the 15th element and CMUT element which is near to the focal point is triggered last in the above case it is 0th element. The other CMUT elements are been triggered respective delay values stored in the LUT.

The comparison of square root architecture and LUT based architecture

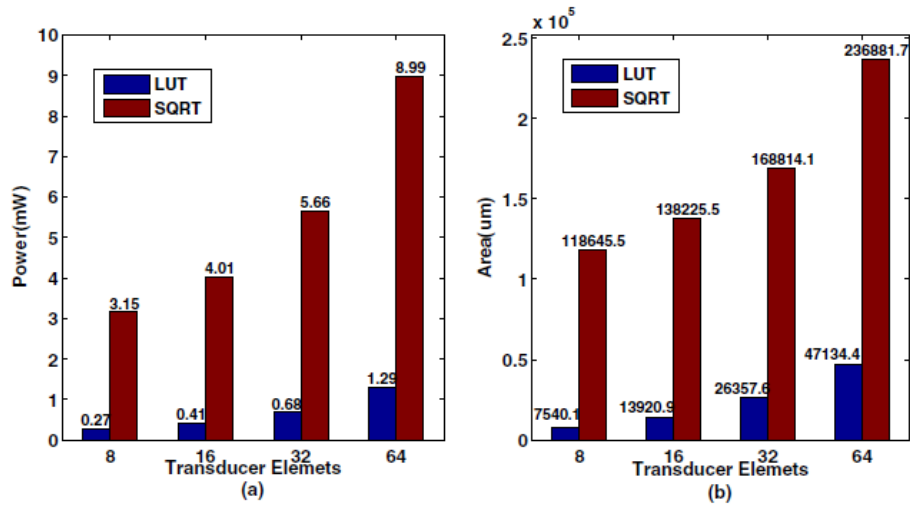

Fig 4.3 LUT vs Square root architecture in terms of power and area [19]

It can be seen from the graph that the area and power for LUT based method almost doubles as the number of elements to be clocked doubles. This can be attributed to the fact that both the size of LUT (number of values) as well as the associated logic doubles with the number of transducer elements. For the SQRT architecture the area increases only by 16.5% when number of elements increase from 8 to 16. However when the elements are increased from 32 to 64, the increment in area is 40.3%. This increase can be ascribed to the increase in routing area as the number of elements goes up. Thus we can notice that even though the computational unit remains the same in SQRT architecture, the area of the architecture increases significantly due to the increase in the routing area.

Though the power and area of LUT architecture nearly doubles, it is still 5.02 and 6.97 times less than that of the SQRT architecture for 64 element design. This shows that LUT architecture has a clear advantage over the state of the art architecture in terms of circuit complexity even for higher number of transducer elements.

Chapter 5

Dual Angle Beamforming Architecture

5.1 Outline

This is the novel approach we introduced in the Beamforming logic, with this approach the distance between focal point and array element expression becomes simpler there by reducing the number of computations taking place in a single clock cycle.

This approach gives the better results compared to the square root architecture. It consists of following modules in its architecture

- (i) Cordic module
- (ii) Divider module
- (iii) Multiplier module
- (iv) Control unit

5.2 Dual Angle approach

Introduction of one more angle in the Beam forming logic makes complex expression of distance calculation to a simpler expression, and implementation can be done with minimum number of components which helps in reducing power and area by drastic amounts.

We introduce one more angle β in our design, for every angle α the angle β for the respective i^{th} array element is constant similarly for every α angle the respective β angles from i^{th} array elements are constant. The distance calculation in case of dual angle based approach is shown below

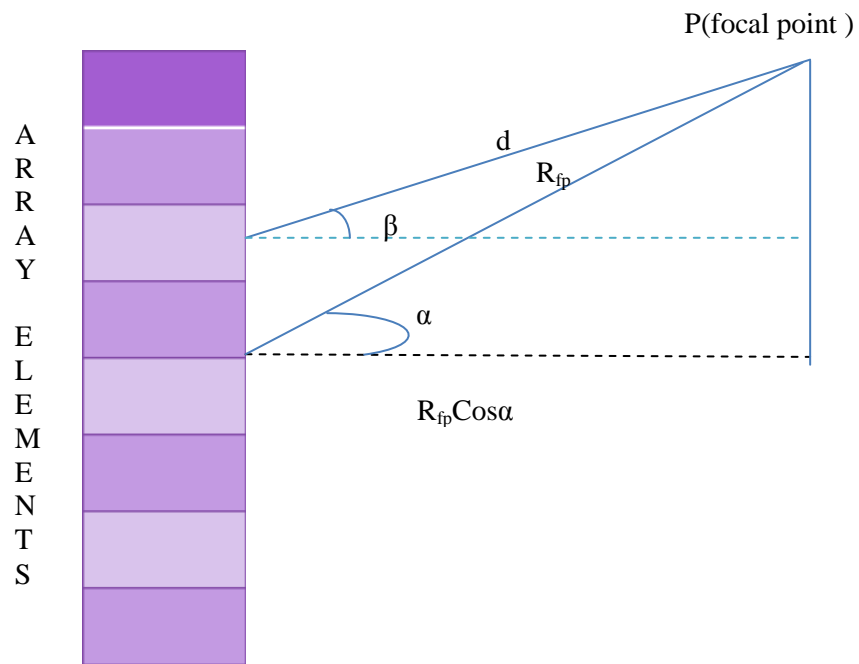

Fig 5.1 Distance calculation in dual angle architecture

P = focal point

R_{fp} = Focal Length i.e distance from center of array to focal point

d = distance to be calculated

The distance calculation are given by expressions

$$\cos \beta = R_{fp} \cos \alpha / d$$

$$d = R_{fp} \cos \alpha / \cos \beta \longrightarrow 1$$

The architecture model of dual angle approach is shown below fig.

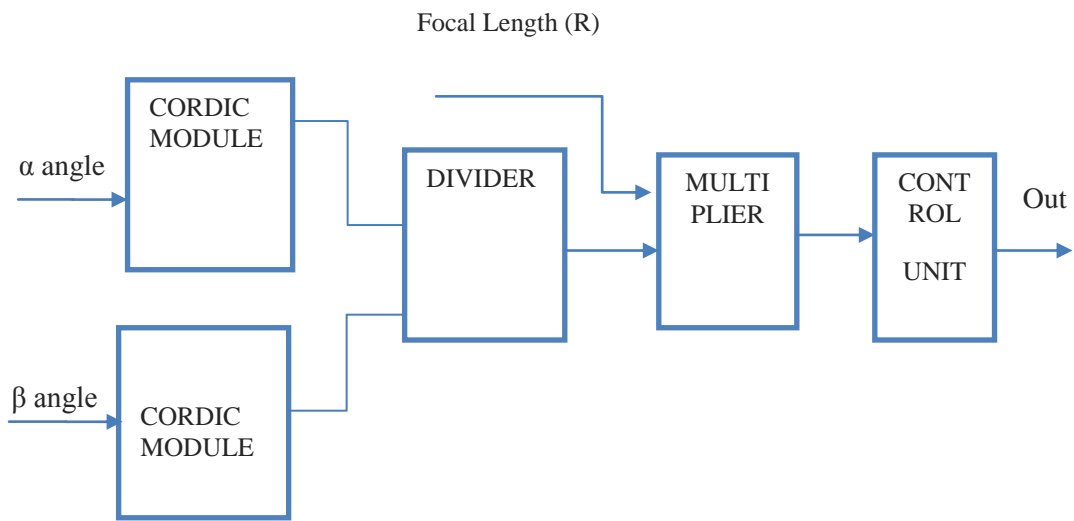

Fig.5.2 Architecture model Dual Angle approach

Angle α is given as input to one of the cordic module and angle β is given as input to the other cordic module, from both the cordic modules we compute $\text{Cos}\alpha$ and $\text{Cos}\beta$ at the clock cycle. $\text{Cos}\alpha$ and $\text{Cos}\beta$ values are given as input to the divider module which computes $\text{Cos}\alpha / \text{Cos}\beta$. $\text{Cos}\alpha / \text{Cos}\beta$ and focal length R as given as inputs to multiplier which computes the distance between the focal point to the array element i.e. $d = R_{fp} \text{Cos}\alpha / \text{Cos}\beta$.

The control unit here is responsible for conversion of distance into time, delay calculations and triggering the corresponding transducer element.

The Power and area reports for Dual angle based approach are shown below

Tab 5.1 showing area and power results of Dual angle approach

Complete Module	Area Report(um2)	Power Report(mw)
8 array elements	131146	1.8
16 array elements	142832	2.9
32 array elements	143231	3.1

Tab 5.2 area and power reports comparison of square root architecture and Dual angle architecture

	Square Root Technique		Dual Angle Beam forming Technique	
	Area Report(um2)	Power Report(mw)	Area Report(um2)	Power Report(mw)
8 array elements	118645	3.15	131146	1.8
16 array elements	138225	4.01	142832	2.9
32 array elements	168814	5.66	143231	3.1

Dual angle Beamforming Technique shows better area and power results compared to square root architecture this is because the mathematical expression of dual angle beamforming technique gives us feasibility of reduction in complexity of the design and number of computations that are been taking place in single clock cycle which eventually reduces the area and power consumption compared to square root architecture.

Chapter 6

Variable Focal Length Beam Forming Technique

6.1 Variable focal length approach

In this approach we get the flexibility of varying the focal length which is more compatible for the present scenario of ultrasound scanners, when compared to square root and LUT based architecture where we could achieve variable focal length. Variable ultrasound scanners are used for multiple biomedical applications.

Variable focal length is achieved by giving focal length(R) as input and using one more LUT named as Modified LUT in our design, as given focal length varies Modified LUT also changes accordingly.

The Precomputed values of $\cos\alpha / \cos\beta$ for different α and β values are stored in LUT. When focal length is given as input to design, focal length value and precomputed values of $\cos\alpha / \cos\beta$ are passed as inputs to the multiplier. The output of the multiplier i.e product of $\cos\alpha / \cos\beta$ and focal length are stored in modified LUT.

The control block is responsible for comparing the value in the modified LUT with counter value and triggering the corresponding transducer array element.

The design is done targeting Application Specific Integrated Circuit (ASIC) platform at Vdd 1.62V for UMC 180nm technology. The power and area analysis are done using Synopsys DC Compiler Tool and Backend part of the design is done using Synopsys IC Compiler Tool. The RTL coding of the design is done using Xilinx ISE 14.1, and RTL and netlist verification is done using Synopsys Formality Tool.

The architecture model of variable focal length is shown below.

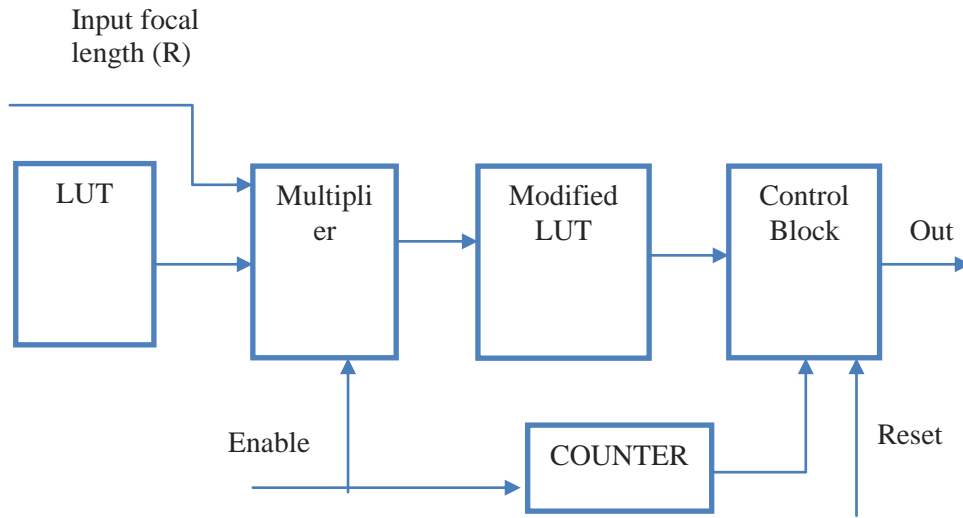

Fig 6.1: Variable Focal Length Beam Forming Architecture

Tab. 6.1 Fixed focal length Results

Array elements	Power Report(mw)	Area Report(um2)	% power use by registers
8 elements	0.1418	3505	95
16 elements	0.2053	7261	94
32 elements	0.3274	7847	96

Tab. 6.2 Variable focal length Results

Array elements	Power Report(mw)	Area Report(um2)	% power use by registers
8 elements	0.1553	9013	86
16 elements	0.2363	20338	81
32 elements	0.3586	21000	87

Achieving Variable length gives us feasibility that the same ultrasound scan can be multiple biomedical applications such as imaging of internal organs, and measurement of blood flow and soft tissue deformations.

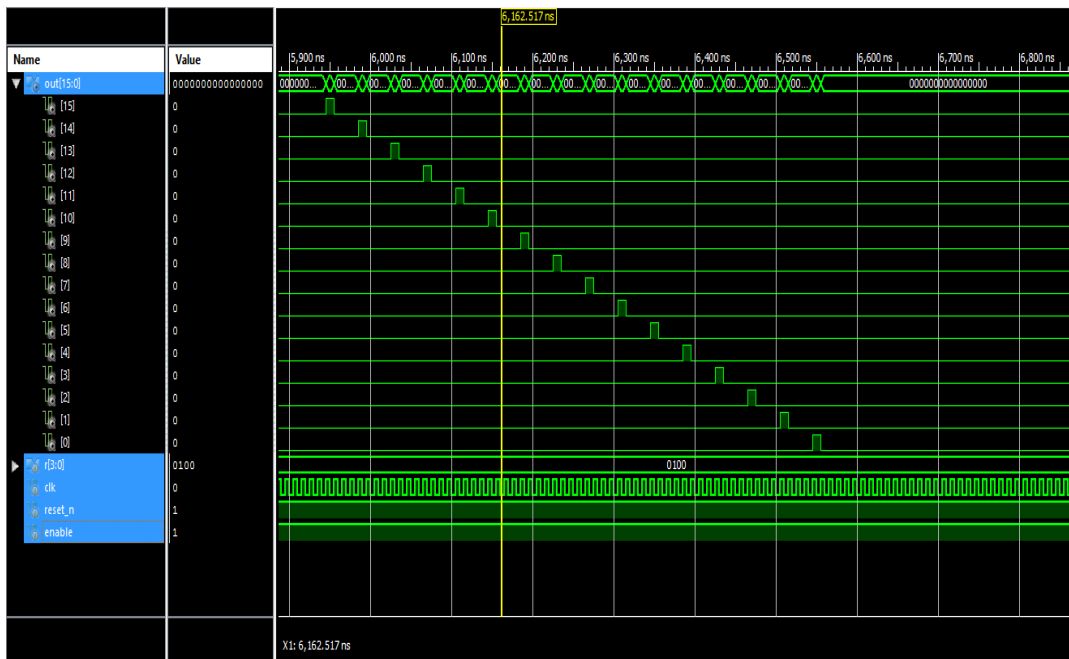

Fig 6.2 simulation results of 16 array elements

The simulation results show the time when the transducer elements are triggered, when focal length(r) varies according to the modified LUT, and the control unit triggers the corresponding transducer elements. It can be seen from the simulation that the transducer

element far from the focal point is triggered first and the transducer near to the focal point is triggered last.

In the simulation result we can see focal length (r) is given as input to the design. This makes the design feasible to give various focal length values and the corresponding delay values are calculated and stored in Modified LUT.

By varying the focal length the same beamforming circuit is used to scan different depths of the human body. This approach helps to use one ultrasound scanner for different biomedical applications.

Chapter 7

Literature study and Future Work

7.1 Ultrasound Receiver

The Beamforming receiver is used to amplify and demodulate the received echo signals, provide the proper time delay in each channel, and add the signals. The conventional digital beamformers use Nyquist rate analog to digital converters ADCs as interpolation filter to effectively up-sample the digital sample, so that accurately delayed samples are obtained [23,25]. However, this increases the hardware complexity.

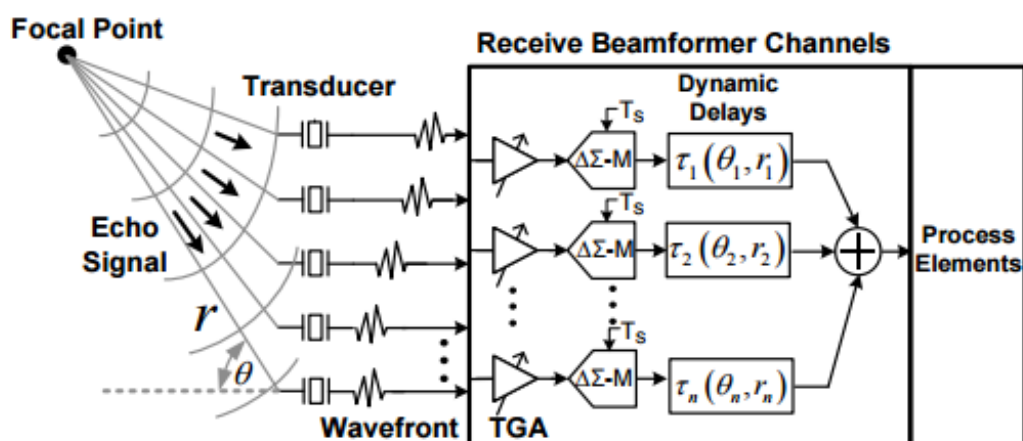

Fig 7.1 Block Diagram of an ultrasound receiver using dynamic focusing [25]

As shown in Fig. 7.1, in the $\Delta\Sigma$ ADC based beamforming receiver, there is a digital signal processing circuitry which applies the dynamic delays to the digitized output of the $\Delta\Sigma$ modulator in the each and every channel, so that a coherent combination of the received signals will be focused at points along in the direction of interest [25]. In the few reported use of $\Delta\Sigma$ modulation in biomedical ultrasound beamformers [22,25], the dynamic range is only around 60 dB. The ultrasound sends a signal pulse at F_0 during the detection of the blood flow by a pulsed Doppler ultrasound receiver.

The returning echo has a strong component at F_0 from stationary tissue at faster blood flow and a very weak signal within 1 kHz of F_0 due to the slow blood flow. For detecting the weak blood flow signal in the presence of the strong signal from the tissue, it requires a dynamic range larger than 12 bits.

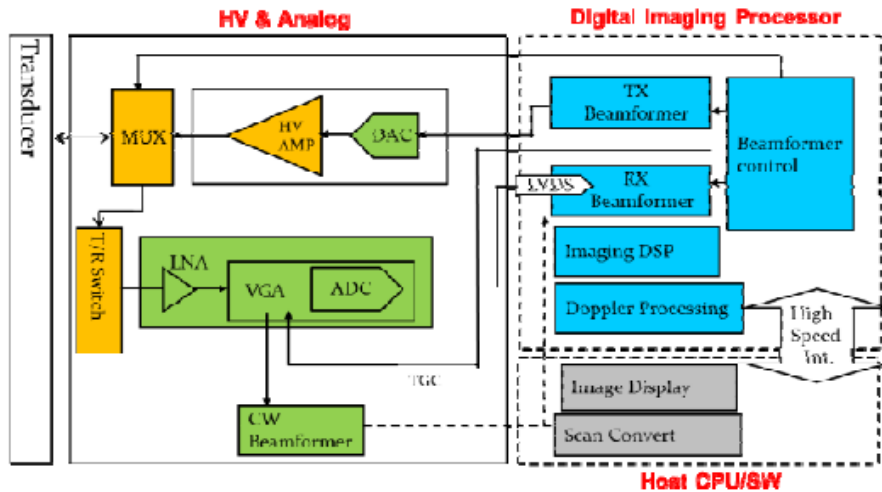

Fig. 7.1 Medical Ultrasound imaging system [26]

Ultrasound imaging system which mainly consists of ultrasound transducers, A/D & D/A converters, receivers, transmitters, timing controller and image processing functions. Among these functional blocks, beam forming block takes a significant amount of computations which are proportional to number of channels that are been used in the design. Accordingly, the customized implementation of beam forming is highly demanded[23,21].

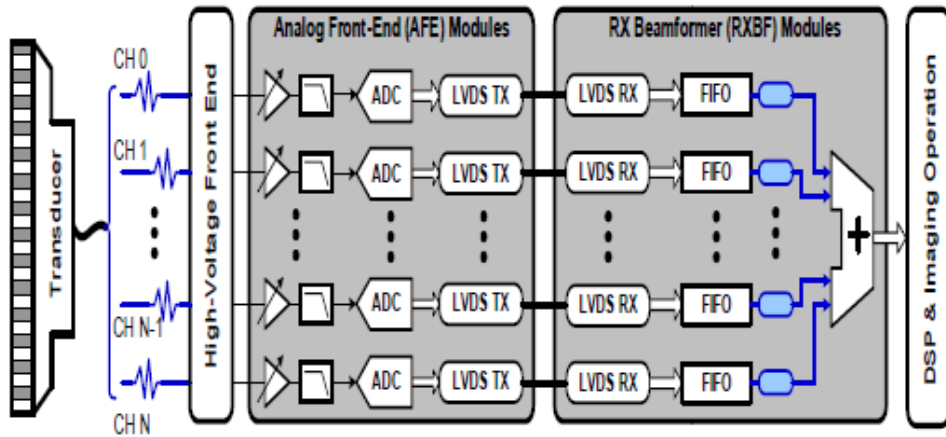

Fig 7.2 Block diagram of a multi-channel ultrasound receiving system [26]

A multi-channel ultrasound receiving system is displayed in Fig 7. 2, including the N-array transducer, high-voltage frontend module, Analog Front-End (AFE) module, LVDS data transmitting/receiving (TX/RX) units and receiving beamformer (RXBF) module. The RXBF is receiving data from the AFE and then conducting beamforming Delay-and-Sum (DAS) operations of which computations used to be fulfilled by FPGAs and general-purpose processors due to flexibility. However, with the rapid development of handheld ultrasound systems, it is critical to implement a customized RXBF to enhance computation and reduce power consumption[23,24].

Chapter 8

Conclusion

8.1 Summary of work done

In this thesis, we have examined the design, implementation, of square root architecture based beamforming circuit, LUT based beamforming architecture. We proposed novel design of beamforming i.e. Dual angle based beamforming architecture, Variable focal length beamforming technique.

We compared the area and power results of square root architecture and LUT architecture, we found that LUT based architecture gives the better results compared to the Square root model. We have seen the simulation results i.e delays where the transducer elements gets triggered for 8 array elements,16 array elements,32 array elements for both LUT model and Square root model.

The proposed Dual angle based beamforming architecture consumes approximately half of the power that of square root model but the area occupied in both the architecture models is same. It is shown in dual angle approach the distance expression(distance between focal point and array element) is simpler and the computations that are taking place in a clock cycle are less compared to the square root model. The area and power reports of dual angle approach are also shown.

The area and power results of fixed focal length and variable focal length are compared and it seen that fixed focal length has shown better results, advantage of using variable focal length is cleared mentioned i.e variable focal length architecture can be used at focus at a different focal lengths that gives the edge over fixed focal length model to use variable focal length approach to various biomedical applications.

References

- [1] Recent Trends in Beam formation in Medical Ultrasound 2005 IEEE Ultrasonics Symposium Rotterdam, Kai E. Thomenius, GE Global Research, Niskayuna NY
- [2] Medical news today article, Christian Nordqvist
- [3] Ultrasonic Imaging Transceiver Design for CMUT: A Three-Level 30-Vpp Pulse-Shaping Pulser With Improved Efficiency and a Noise-Optimized Receiver. Kailiang Chen, Member, IEEE, Hae-Seung Lee, Fellow, IEEE, Anantha P. Chandrakasan, Fellow, IEEE, and Charles G. Sodini, Fellow, IEEE
- [4] A Simulation study of Beam steering characteristics for Linear Phased arrays. Shi-Chang Wooh, Yijun Shi
- [5] D. Turnbull and F. Foster, "Beam steering with pulsed 2-dimensional transducer arrays," IEEE Transactions on Ultrasonics, Ferroelectrics and Frequency Control, vol. 38, no. 4, pp. 320-333, Jul. 1991
- [6] Azar, L., Y. Shi, and S-C. Wooh. "Beam focusing behavior of linear phased arrays." NDT & E International 33, no. 3 (2000): 189-198
- [7] K. E. Thomenius, "Evolution of ultrasound beamformers." IEEE Ultrasonics Symposium, Vol. 2, 1996.
- [8] Z. Zhao, T. Xiang, M. Gao, C. He, X. Zhang, and X. Jin "A pipelined beamforming delay calculation architecture in ultrasound imaging system." Computer Science and Automation Engineering (CSAE), 2011 IEEE International Conference on. Vol.1. IEEE, 2011.
- [9] Fenster, D. Downey, and H. Cardinal, "Three-dimensional ultrasound imaging," Physics in Medicine and Biology, vol. 46, no. 5, pp. R67-R99, May. 2001.

- [10] R. Davidsen, J. Jensen, and S. Smith, "2-dimensional random arrays for real-time volumetric imaging," *Ultrasonic Imaging*, vol. 16, no. 3, pp. 143-163, Jul. 1994.
- [11] C. Harvey, J. Pilcher, R. Eckersley, M. Blomley, and D. Cosgrove, "Advances in ultrasound," *Clinical Radiology*, vol. 57, no. 3, pp. 157-177, Mar. 2002.
- [12] B. D. Steinberg, *Principles of aperture and array system design: Including random and adaptive arrays*. New York: John Wiley & Sons, 1976.
- [13] M. I. Haller and B. T. Khuri-Yakub, "A surface micromachined electrostatic ultrasonic air transducer," 1994 IEEE Ultrasonics Symposium, pp. 1241-1244, 1994.
- [14] P. T. Khuri-Yakub, "Next-gen ultrasound," *IEEE Spectrum*, May 2009.
- [15] X. Jin, I. Ladabaum, and B. T. Khuri-Yakub, "The microfabrication of capacitive ultrasonic transducers," *IEEE J. Microelectromech. Syst.*, vol. 7, pp. 295-302, Sept. 1998.
- [16] O. Oralkan, A. S. Ergun, J. A. Johnson, M. Karaman, U. Demirci, K. Kaviani, T. H. Lee, and B. T. Khuri-Yakub, "Capacitive Micromachined Ultrasonic Transducers: Next-Generation Arrays for Acoustic Imaging", *IEEE Transactions on Ultrasonics, Ferroelectrics, and Frequency Control*, vol. 49, pp. 1596-1610, 2002.
- [17] B. Bayram, O. Oralkan, A. S. Ergun, E. Hggstrom, G. G. Yaralioglu, and B. T. Khuri-Yakub, "Capacitive Micromachined Ultrasonic Transducer Design for High Power Transmission", *IEEE Transactions on Ultrasonics, Ferroelectrics, and Frequency Control*, vol. 52, pp. 326-339, 2005.
- [18] G. G. Yaralioglu, A. S. Ergun, and B. T. Khuri-Yakub, "Finite-Element Analysis of Capacitive Micromachined Ultrasonic Transducers", *IEEE Transactions on Ultrasonics, Ferroelectrics, and Frequency Control*, vol. 52, pp. 2185-2198, 2005.

- [19] A Low Power, Area Efficient FPGA Based Beamforming Technique for 1-D CMUT Arrays. Bastin Joseph, Jose Joseph and Siva Rama Krishna Vanjari
- [20] S. E. Noujaim, S. L. Garverick, and M. O'Donnell, "Phased array ultrasonic beam forming using oversampled A/D converters," U.S. Patent 5,203,335, April 20, 1993.
- [21] R. G. Pridham and R. A. Mucci, "Digital interpolation beamforming for low-pass and bandpass signals," Proc. IEEE, vol. 67, pp. 904-919, June 1979.
- [22] S. Freeman et al., "Delta-sigma oversampled ultrasound beamformer with dynamic delays," IEEE Trans. Ultrasonics, Ferroelectrics, and Frequency Control., vol. 46, No. 2, Mar. 1999.
- [23] G. Gurun et al., "An analog integrated circuit beamformer for highfrequency medical ultrasound imaging," IEEE Trans. Biomed. Circuits Syst., vol. 6, pp. 454 - 467, Oct. 2012.
- [24] P. Song, K-T Tiew, Y. Lam, and K. L. Mong, "A CMOS 3.4mW 200 MHz continuous-time delta-sigma modulator with 61.5 dB dynamic range and 5 MHz bandwidth for ultrasound application," in Proc. 50th Midwest Symp. Circuits and Systems, pp. 152-155, 2007.
- [25] B. Tov, M. Kozak, E. G. Friedman, "A 250 MHz delta-sigma modulator for low cost ultrasound/sonar beamforming applications," IEEE ICECS, pp. 113-116, Dec 2004
- [26] High frequency and power efficiency ultrasound beamforming processor for handheld applications ,Guo-Zua, Song-Nein Tang, Chih-chi chang and Chein Ju Lee