

Settlement of Two Layered Soil System due to Rectangular Footing

Preethi Sekar

A Dissertation Submitted to
Indian Institute of Technology Hyderabad
In Partial Fulfilment of the Requirements for
The Degree of Master of Technology



भारतीय प्रौद्योगिकी संस्थान हैदराबाद
Indian Institute of Technology Hyderabad

Department of Civil Engineering

May, 2016

Declaration

I declare that this written submission represents my ideas in my own words, and where others' ideas or words have been included, I have adequately cited and referenced the original sources. I also declare that I have adhered to all principles of academic honesty and integrity and have not misrepresented or fabricated or falsified any idea/data/fact/source in my submission. I understand that any violation of the above will be a cause for disciplinary action by the Institute and can also evoke penal action from the sources that have thus not been properly cited, or from whom proper permission has not been taken when needed.

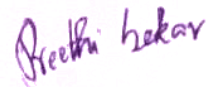

Preethi Sekar

CE13M0002

Approval Sheet

This thesis entitled **Settlement of a Two Layered Soil System underlain by a Rigid Base** by **Preethi Sekar (CE13M0002)** is approved for the degree of Master of Technology from IIT Hyderabad

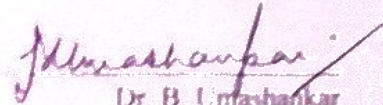

Dr. B. Umfashankar
Associate Professor
Department of Civil Engineering
Indian Institute of Technology Hyderabad
Adviser

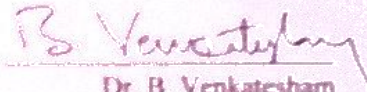

Dr. B. Venkatesham
Assistant Professor
Department of Mechanical Engineering
Indian Institute of Technology Hyderabad
Examiner

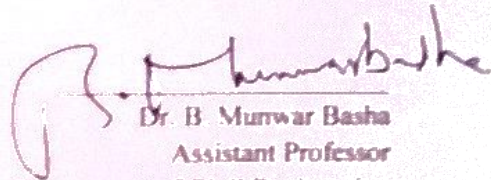

Dr. B. Murwar Basha
Assistant Professor
Department of Civil Engineering
Indian Institute of Technology Hyderabad
Examiner

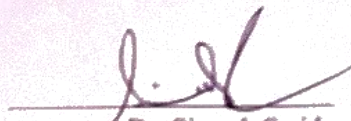

Dr. Sireesh Saride
Associate Professor
Department of Civil Engineering
Indian Institute of Technology Hyderabad
Examiner

Acknowledgements

My sincere thanks to my advisor Dr. B. Umashankar for his continuous support and motivation. I would also like to thank all the faculty members of the Department of Civil Engineering, IIT Hyderabad. My sincere gratitude also extended to Dr. B. Venkatesham, Department of Mechanical Engineering.

I am grateful for my family members, especially to my father, Dr. S. P. Sekar, for his undying support in pursuing my dream. My profound thanks to my seniors, Hari Prasad, Sasanka Mouli, Bhagath Singh, Sahith Gali, Raghuram, Saranya Selvam, Roji, Ravi Teja K. V. N. S., Pranav Peddinti, Deepti Avirneni. I also appreciate the warm support extended by Aranya Getta, Troyee Tanu Datta, Mekala Rajashekhar, Thejesh Kumar Garala, Rishitha, Natasha, Durga Prasad, Subhavana Katakam and Lalitha Poduri. My special thanks to Sajal Sagar Singh and Aditya Aagare for being an inspiration.

Dedicated to

My Father, for believing in me

Abstract

Settlement of a semi-infinite, homogenous soil stratum due to various loading types and shapes is readily available in literature. However, ground profile is seldom homogenous and typically consists of layered soils. Authors have often come across ground profiles consisting of layered soils underlain by a rock stratum. This study deals with the immediate settlement of a two-layered soil system due to loading on a rectangular area. Elastic analysis is performed using finite elements for a wide range of geometric and soil properties. The settlement of a shallow footing depends on various other factors like shape of the footing, depth of embedment and rigidity of the footing apart from the load on the footing. Influence factors are introduced to include the effects of the factors influencing the settlement. The influences of the factors are studied independent of the other influencing factors. Design engineers can use the settlement influence factors proposed in the form of charts to estimate the settlement at the centre of the loading. In addition, the settlement profiles in both x and y directions are also presented. The results from the study showed good agreement with the validation studies done by various researchers as discussed in each chapter.

Nomenclature

- L - Length of the rectangular footing, m
- B - Breadth of the rectangular footing, m
- E_1 - Modulus of elasticity of the top layer, MPa
- E_2 - Modulus of elasticity of the top layer, MPa
- H_1 - Thickness of the top layer, m
- H_2 - Thickness of the bottom layer, m
- D - Depth of embedment, m
- ν_1 - Poisson's ratio of the top layer (no unit)
- ν_2 - Poisson's ratio of the bottom layer (no unit)
- ρ - Settlement of the rectangular footing, m
- I_p - Settlement influence factor for flexible rectangular footing (no unit)
- $I_{p, \text{rigid}}$ - Settlement influence factor for rigid rectangular footing (no unit)
- $I_{p, \text{depth}}$ - Settlement influence factor for flexible rectangular footing at a depth (no unit)
- $I_{p, \text{circle}}$ - Settlement influence factor for flexible circle footing (no unit)
- x - Distance from the centre of the footing in the x direction, m
- y - Distance from the centre of the footing in the y direction, m

Contents

Declaration.....	ii
Approval Sheet	iii
Acknowledgements.....	iv
Abstract.....	vi
Nomenclature	vii
1 Introduction.....	1
1.1 Overview.....	1
1.2 Objectives of the study.....	3
1.1 Organisation of study.....	4
2 Literature Review	5
2.1 Introduction.....	5
2.2 Rectangular footings	6
2.2.1 Semi-infinite soil layer	8
2.2.2 Single finite layer of soil	9
2.3 Footings on a two layered soil system.....	10
2.4 Poisson's ratio	11
2.5 Approximation by shape conversion	12
2.6 Rigidity of footing	13
2.7 Depth of embedment of footing.....	15
3 Modelling in PLAXIS 3D	16
3.1 Introduction.....	16
3.2 Problem Definition.....	17
3.3 Finite Element Analysis	18
3.4 Advantages of PLAXIS 3D	18
3.5 Finite Elements	19
3.6 Boundary Conditions	20
3.7 Meshing	21
3.7.1 Refinement of Surfaces.....	22
3.7.2 Volume refinement.....	22

3.8	Convergence Study	22
4	Poisson Ratio Effect	24
4.1	Introduction	24
4.1	Equivalent Settlement factors for Poisson ratio	25
4.1	Example Problem	26
5	Settlement due to uniform rectangular footing on two layer system.....	27
5.1	Introduction	27
5.2	Problem Definition	27
5.3	Validation	28
5.3.1	Case Study 1- Savings Bank, Adelaide, Australia	28
5.3.2	Case Study 2- Leaside Towers, Ontario, Canada	30
5.4	Maximum Settlement Influence Factors	31
5.4.1	Effect of Poisson's ratio	32
5.4.2	Effect of H_1/B	32
5.4.3	Effect of H_2/B	37
5.4.4	Effect of L/B	38
5.5	Maximum Settlement Influence Factors	38
6	Comparison of Settlement of equivalent area of Footing.....	42
6.1	Introduction	42
6.2	Problem Definition	44
6.3	Results and Discussion	44
6.3.1	Semi-infinite Layer	45
6.3.2	Finite Layer	46
6.4	Comparison between Rectangular and Circular Footing	49
7	Rigidity of Footing	50
7.1	Introduction	50
7.2	Problem Definition	51
7.2.1	Finite Layer of Soil	52
7.2.2	Two Layer Soil System	52
7.3	Finite Element Model	52

7.4	Validation	53
7.5	Result and Discussion.....	54
7.5.1	Finite one layer of soil.....	55
7.5.1.1	Influence of L/B ratio	55
7.5.1.2	Influence of H/B	55
7.5.2	Two Layer Soil System.....	56
7.5.2.1	Influence of L/B	56
7.5.2.2	Influence of E_1/E_2	57
7.5.2.3	Influence of H_1/B	58
7.5.2.4	Influence of H_2/B	59
7.3	Comparison	59
8.	Rigidity of Footing	61
8.1	Introduction	61
8.2	Problem Definition.....	61
8.3	Validation	62
8.4	Settlement influence factors at depth of embedment.....	63
8.5	Settlement at the center along the depth.....	72
8.	Conclusions.....	79
	References.....	83

Chapter 1

Introduction

1.1 Overview

Foundations are an integral part of a structure used in transferring the load of the superstructure to the soil below. The foundations are classified in two categories- shallow and deep foundations. Shallow foundations are generally opted where the soil conditions are adequate at shallow depths to carry the load coming on from the superstructure. Shallow foundations are cost effective, easy to build, and require least specialized equipment. The shape of the shallow foundations for a structure may vary. This depends on the load coming in from the superstructure. The common shallow foundations are isolated footing, combined footing, strip footing, strap footing and mat footing. When the load coming from a single column needs to be transferred, generally isolated footing in the shape of square is preferred. However, due to moment loads or constraint in the site boundary, as in the case of footings very close to the boundary of the plot, the shape is modified to be a rectangular footing. Rectangular footings have been used for a long time in the foundations of structures. However, the exact formulation for the settlements of a rectangular footing has been approximated by converting its area into an equivalent circular footing or square footing.

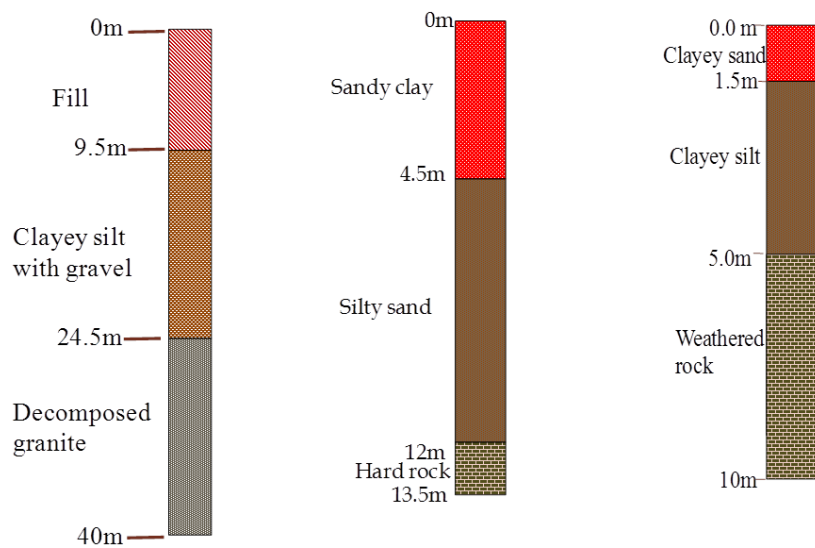

Figure 1.1. Soil Profiles Showing Two Layer Soil System

Soil profile in Kandi Campus of IIT Hyderabad has a distinct two layer soil system followed by a rigid layer consisting of rocks. Similar soil profiles have also been identified in Bangalore and Hong Kong as reported by researchers [Anbazhagan and Sitaram (2006) and Zhang and Dasaka (2010)]. Figure 1.1 shows the profiles by the above authors. Researchers like Harr(1966) and Giroud(1968), Ueshita and Meyerhof(1968), Davis and Taylor(1962), and Burmister(1962) have analysed the settlements for workable loads, a comprehensive summary of which has been provided for elastic settlements by Poulos and Davis (1974). The solutions provided are for soils with homogeneous soil properties and extending semi-ininitely in all directions, or for a finite thickness of soil (homogenous soil underlain by a rigid base). Averaging the properties of the soil of different layers may lead to erroneous results in estimating the settlements, especially if the soils' properties are widely different.

The settlement of a shallow footing depends on various other factors like shape of the footing, depth of embedment and rigidity of the footing. The settlement of the shallow footing is generally calculated using Equation (1.1)

$$\rho = \frac{qB(1-\nu^2)}{E_2} I_\rho \dots\dots\dots(1.1)$$

where, ρ is the settlement of the footing, q is the load applied on the footing, B is the width of the footing, ν is the Poisson's ratio, E_2 is the deformation modulus of the second soil layer, and I_ρ is the influence factor of the settlements.

Influence factors are introduced to include the effects of the above-mentioned factors influencing the settlement. The influences of these factors are studied independent of the other influencing factors. With soil profiles as shown in Figure 1 commonly available, it is necessary to produce solutions for two layered soil system underlain by a rigid base. Also rectangular footings are common types of footing used in field conditions. The project presents a detailed review on the settlements of a rectangular footing on a two layered soil system underlain by a rigid base in chapters. You have to present here the shortcoming of the existing methods. For e.g., that they do not provide solutions for two-layered system underlain by a rock stratum.

1.2 Objectives

- To analyse the behaviour of two-layered soil system underlain by a rigid base, soil parameters are varied for various aspect ratios of the rectangular footing. The soil parameters varied for the soil system includes Deformation modulus and the Poisson's ratio. The thickness and the rigidity of the footing is also varied to completely understand the behaviour of the footing on a two layered system.
 1. Shape and size of the footing and analysing the settlement response of the footing
 2. Poisson's ratio
 3. Rigidity of the rectangular footing
 4. Depth of embedment of the footing on the settlement response
- Settlement influence factors are proposed to include the variation in settlements considering all the variations caused by the above-mentioned parameters. PLAXIS 3D v AE is used to analyse the above-mentioned parameters.

- To analyse the validity of shape conversion in approximating the settlement values from that of a circular footing

1.3 Organization of Study

Chapter 2 deals with the existing literature review on rectangular footings, their basis in analysis and presents literature on the two-layered soil system. This Chapter also emphasizes on the necessity to include factors like rigidity, depth of embedment in the formulation. Chapter 3 provides the background on modelling with PLAXIS 3D, a Finite Element Analysis software, in three dimensions. It also explains the modelling parameters used such as the soil model, meshing and other basic parameters.

Chapter 4 presents the effect of Poisson's ratio on the soil and the approximation method for formulating the settlement for different values of Poisson's ratio. Chapter 5 presents the settlement influence factor for rectangular flexible footing on a two-layered soil system underlain by a rigid base. Chapter 6 compares the influence factor obtained for rectangular footing to that of a circular footing. Rigidity of the footing is explained in chapter 7. Chapter 8 deals with the depth of embedment and proposes factors to explain the change in settlement by varying the depth of embedment. Chapter 9 gives a summary of the factors proposed and a brief discussion on the results obtained along with the conclusion.

Chapter 2

Literature Review

2.1 Introduction

Foundation is a part of the engineered system that transmits to, and into, the underlying soil or rock, the loads supported by the foundation and its self-weight. However, foundations may also carry just machinery, tanks, industrial equipment etc. Foundations can be classified as shallow and deep foundations according to how the load is being transferred to the ground. Shallow foundations are classified based on their shapes as rectangular, circular, square or as isolated, combined, raft and strip footing. For the structure to be stable, Soil should fail neither in shear failure nor should fail in deformation. In most cases, this criterion takes care of the bearing capacity criteria. In case of settlement failures, generally the failure is gradual and hence the failure can be remedied. The failure due to uniform settlement generally does not lead to the collapse of structure.

When differential settlement occurs, the cracks form in the structure leading to the collapse of the structure. Soil settlements are the best estimation of how the soil deforms when a load is applied on it. The deformation of soil happens in all the directions, while the vertical settlement of a foundation is often considered critical. The settlements are generally classified as immediate, primary, and secondary or consolidation settlements. Immediate settlement is the settlement that occurs as the load is applied or within a short period of time. For granular soils, the elastic or immediate settlement account for more than 90% of the total settlement.

As mentioned earlier, many studies are available on the study of rectangular loading and on two layered soil system for various shapes. However, rectangular footing is a common type of footing and two layers of soil underlain by rigid base criteria have not yet been studied. This chapter provides a detailed review of the studies available on settlement of rectangular footings and on two layered soil systems.

The basic expression for surface settlements of a flexible circular footing founded on the surface of a semi- infinitely thick soil layer is given as in Equation 2.1,

$$\rho = \frac{qB(1-\nu^2)}{E} \dots\dots\dots(2.1)$$

where, ρ is the settlement of circular footing, q is the loading acting on the soil, B is the width or diameter of the footing, ν is the Poisson ratio of the soil, and E is the elastic modulus of the soil. However, in reality the settlement also depends on the depth of embedment, shape of the footing, rigidity of the footing. To depict the influence of these factors researchers introduced a factor called influence factor, I_p that produces a multiplying factor to correct the settlement values based on the above-mentioned factors that influence settlements. Various methods provided by the researchers are stated below for rectangular footings on semi-infinite and finite layered soil system. The chapter also discusses the effect of Poisson's ration, footing rigidity and the depth of embedment and its effect on settlement as provided by previous researchers.

2.2 Rectangular Footings

2.2.1 Footing on Semi-Infinite Soil Layer

Harr (1966) proposed the settlement at the corner of a rectangular loading at any depths acting on elastic, semi- infinite soil as in Equation 2.1. He proposed influence factor, given by Equation 2.2, by introducing factors A and B dependent on factors m_1 and n_1 .

$$\rho_z = \frac{pb(1-\nu)^2}{E} \left(A - \frac{1-2\nu}{1-\nu} B \right) \dots\dots\dots(2.2)$$

where

$$A = \frac{1}{2\pi} \left(\ln \frac{\sqrt{1+m_1^2+n_1^2}+m_1}{\sqrt{1+m_1^2+n_1^2}-m_1} + m_1 \ln \frac{\sqrt{1+m_1^2+n_1^2}+1}{\sqrt{1+m_1^2+n_1^2}-1} \right), \quad B = \frac{n_1}{2\pi} \left(\ln \frac{m_1}{n_1 \sqrt{1+m_1^2+n_1^2}} \right)$$

p= load on the surface of the footing, l= length of the footing, b= width of the footing, z= depth below the footing, E= elastic modulus and ν= the Poisson ratio of the footing, m₁= l/b and n₁=z/b.

Giroud (1968) represented the vertical mean surface settlements at four points in the form of table and also as chart bearing the influence factors, the four points being the centre of the footing, centre of the long side, centre of the short side and the corner of the footing. The formulation given to apply the influence factor is as in Equation (2.3)

$$\rho_z = \frac{pB(1-\nu^2)}{E} I \dots\dots\dots(2.3)$$

Schleicher(1926) has proposed a rigorous theoretical solution for settlement of a semi- infinite layer of soil for different aspect ratios, L/B, equal to 3,5 and 10. The results obtained by Schleicher were compared with the results obtained by Enkhtur et al. (2013) and was found to be in good agreement up to an aspect ratio of L/B ≤ 2 and the percentage of variation increased with the aspect ratio with 40% variation for L/B of 10.

Mayne and Poulos (1999) proposed the most general and updated solution as given in Equation 2.4

$$\rho_e = \frac{q B_e (1-\nu^2)}{E_0} I_F I_G I_E \quad \dots\dots\dots(2.4)$$

where ρ_e is the elastic settlement at the centre of the footing, q is the uniform stress applied on the footing and B_e is the equivalent diameter of the rectangular footing ($B_e = \sqrt{4BL/\pi}$). I_F , I_G and I_E are the proposed correction factors for foundation rigidity, soil modulus and foundation embedment.

2.2.2 Footing on Single Finite Layer of Soil

Ueshita and Meyerhof (1968) proposed influence factor for vertical settlement at the corner of a flexible rectangular loading on a soil of finite layer as shown in Figure 2.1. The interface between the soil layer and the base is adhesive. The influence factor, I_{rc} , was computed for six different values of Poisson's ratio, and the actual displacement can be computed from the Equation 2.5 where p is the vertical stress per unit area, B is the width of the footing, E is the elastic modulus of the footing.

$$\rho_z = \frac{p B I_{rc}}{E} \quad \dots\dots\dots(2.5)$$

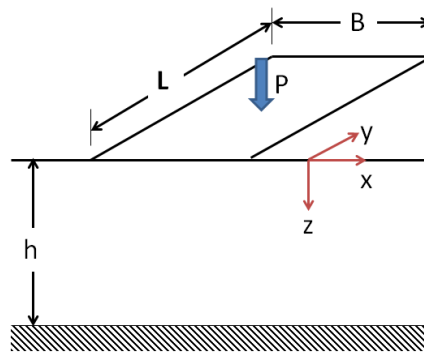

Figure 2.1 Schematics of a finite layer of soil underlain by a rigid base

where, I_{rc} is the influence factor taking into consideration the Poisson's ratio of the soil.

Davis and Taylor (1962) proposed influence factors for both vertical and horizontal surface displacements at the corners of the rectangle for a rough rigid underlying base. Vertical stresses (q_z and q_x) horizontal stresses (q_y) were considered in the formulation. The settlement of the footing at any corner is represented as in

Equation 2.6, where i and j are any of x, y, z , and $0^m_{ij}, 1^m_{ij}, 2^m_{ij}$ are influence factors represented as a chart, $I_{ij} = 0^m_{ij} + 1^m_{ij} + 2^m_{ij}v^2$.

$$\rho_{ij} = q_j \frac{h}{E} (1 + \nu) I_{ij} \dots\dots\dots(2.6)$$

Sovinc (1961) considered the settlement of a rectangular footing on a finite homogenous layer of soil underlain by a rigid base where the interaction between the soil and the rigid base was considered smooth for Poisson's ratio equal to 0.5. The solutions, however, are for large lateral dimensions that the solutions might be a close representative of infinite soil layer than finite layer of soil. The solutions were presented in terms of chart with f_c plotted against h/B for different values of L/B where f_c and f_d are the influence factors and the settlements can be inferred from Equation 2.7.

$$\rho = f_c \frac{pB}{E} \text{ at the centre of the smaller edge and } \rho = f_d \frac{pB}{E} \text{ for centre of the larger side} \dots\dots\dots(2.7)$$

Fraser and Wardle (1976) proposed settlement values for a raft footing on a finite homogenous layered soil and also proposed correction factors for the foundation shape, roughness, and rigidity of the footing when an uniform stress is applied on the soil.

2.3 Footings on two-layered soil system

Burmister(1962) proposed the vertical surface settlement at the centre of the circular footing for the Poisson's ratio of top and bottom layers equal to 0.2 and 0.4, respectively. A solution for Poisson's ratio of both layers equal to 0.5 was later published by Burmister (1945). Thenn de Barros (1967) then produced results where the Poisson's ratio equal to 0.35 for both layers. Ueshita and Meyerhof (1967) introduced an alternative chart where the variation of h/a was plotted against E_a/E_2

for various values of E_1/E_2 through which the settlement values were inferred as from Equation 2.8, where E_a is the equivalent modulus of elasticity for Poisson's ratio of both layers was taken as 0.5. All the above propositions are for circular footings on a layered soil system with adhesive interface between the soil surfaces as shown in Figure 2.2 (a).

$$\rho_z = \frac{1.5 p_a}{E_e}$$

.....2.8

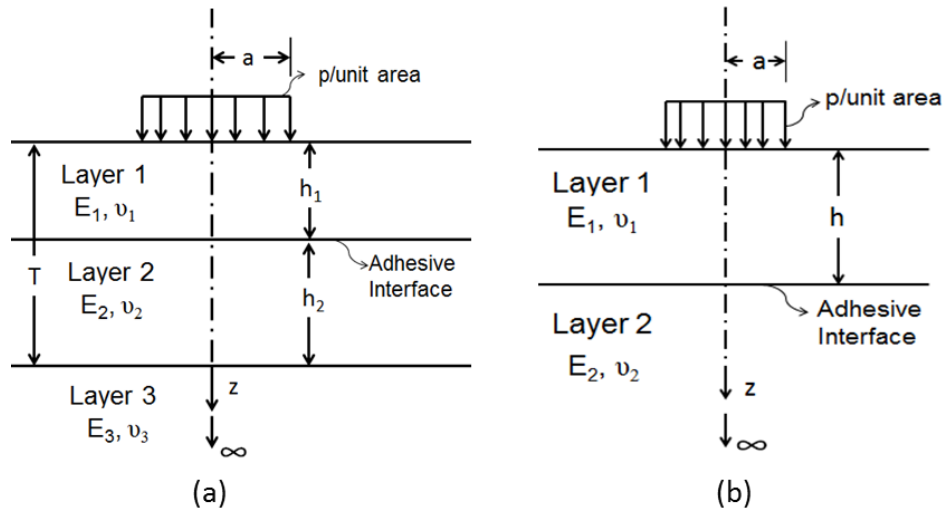

Figure 2.2: Schematic diagram of a two-layered soil system with (a) bottom layer underlain by rigid base, and (b) bottom layer extending semi-infinately

Ueshita and Meyerhof (1967) extended the evaluation of the settlement for a two-layer soil system with the second layer having a semi-infinite depth to two layer finite layer underlain by a semi-infinite layer of soil where the Poisson's ratio is 0.5 for all the three layers. The settlement can be inferred from Equations 2.9(a) and 2.9(b) for the settlement at the centre and the edge respectively. They have analysed the model for the parameters as shown in table 1. Thenn de Barros (1966) published influence factors for vertical displacements at the centre of the circle and tables were for various thickness of the soil layers. The settlement can be inferred from the Equation 2.10 by applying the corresponding influence factor, F. By using the

approximation of the of the area of rectangle to an equivalent area of circle, the settlement can be inferred.

$$\rho_c = \frac{1.5pa}{E_s} F_{co} \dots\dots\dots(2.9 a)$$

$$\rho_s = \frac{1.5pa}{E_s} F_{cs} \dots\dots\dots(2.9 b)$$

$$\rho_c = \frac{1.755pa}{E_s} F \dots\dots\dots(2.10)$$

Table 2.1 Values proposed by various authors for approximation

Author(s)	E ₁ /E ₂	E ₂ /E ₃	v ₁ = v ₂ = v ₃	T/a	H ₁ /T
Ueshita and Meyerhof (1967)	2, 10, 100	2, 10, 100	0.5	0.5, 1, 3, 4	0, 0.2, 0.4, 0.6, 0.8, 1
Thenn de Barros (1966)	2, 5, 10, 20, 50	2, 5, 10	0.35	-	-

Razouki(2009) proposed maximum settlement influence factors for a square footing on a two layer soil system as represented in Figure 2.2 (a). The author has used the variation of similar parameters to study the behaviour of the proposed system. However the results are limited only to square footing and can be extended to circular footing as proposed by the shape conversion method explained in the thesis.

2.4 Effect of Poisson’s ratio

Das (1985) mentioned Boussinesq’s equation by for elastic settlement at the centre of a uniformly loaded flexible rectangular area for a semi- infinite homogeneous layer is represented in Equation 2.1. Approximate effect of Poisson’s ratio can be estimated by using the Equation 2.11. This formulation is applicable only in the case where both the soil layers have the same Poisson’s ratio.

$$I_v = \frac{(1-\nu_a^2)}{(1-\nu_u^2)} \dots\dots\dots(2.11)$$

Where, ν_a is the actual Poisson's ratio and ν_u is the Poisson's ratio used in the tabulation as proposed by Razouki et. al. (2010).

Enkthur (2013) stated that Schiffman (1968) analysed the effect on settlements beneath a perfectly circular rough foundation on elastic half space. Schiffman inferred that the Poisson's ratio affects the settlements of the soil. For example, if the Poisson's ratio of the soil is 0.5, then there is no friction effect on the settlement. However if the Poisson' ratio is zero then the settlement gets reduced to 84% compared to frictionless foundation.

Mayne and Poulos (1999) proposed that the range of drained Poisson's ratio values the earlier proposed might have been over estimated and the practical values to be used generally varies between 0.1 and 0.2 and for un-drained Poisson's ratio it still remains valid to use Poisson's ratio of 0.5.

2.5 Approximation by Shape Conversion

Entkthur et. al. (2013) proposed correction factors for conversion of rectangular footing to equivalent area of circular footing for a semi-infinite layer for L/B less than or equal to 2. They also proposed that if the aspect ratio, $L/B > 2$, then shape conversion gives erroneous results and correction factors should be introduced, if shape is modified. The above examples are restricted only to a particular domain of soil condition or thickness of layers and can't be applied to other footing shapes in all conditions. The authors have proposed or considered converting rectangular footing to equivalent area of square or circular footing while proposing the settlement influence factors.

Prominent researchers in the field have also mentioned converting loading of other shapes to circular shape with equivalent area and then computed settlement or stress

in the soil due to the load. Mayne and Poulos (1999) have recommended conversion of rectangle with sides A and B to a circular of area of $(4AB/\pi)^{1/2}$ for computing the settlements at the centre, which is also the maximum settlement of the load on the soil. Prakash and Puri (2006) state that in case of non-circular footings, equivalent radius is assumed. Fellenius (2006) mentions that conversion from circular to equivalent rectangular footing is also being carried out and this is also applicable for squares. Chakraborty and Kumar (2013) have proposed the bearing capacity factors for the circular footing and they have mentioned that the bearing capacity factors can also be used as a rough estimation of square footings with equivalent area of circular footing.

Enkhtur (2013) has mentioned that Mayne and Poulos (1999) proposed that for aspect ratio of L/B less than or equal to 2, the conversion of rectangular shape of footing to other shapes gives almost the same result by studying the strain in the soil. The authors had also studied the settlement influence factors for the aspect ratio of L/B greater than 2 and they propose that Mayne and Poulos's proposal overestimates the settlement values and the reason for this is that the diameter of the equivalent footing is larger than the actual breadth of the footing. Enkhtur also proposed that the actual breadth (or diameter) of the footing needs to be considered instead of the equivalent breadth (or diameter). All the above authors have done research for a semi- infinite soil layer.

This current study deals with the influence of shape conversion over settlement when the footing is converted from a rectangular footing to an equivalent area of circular or square footing. It also analyses the condition that the soil is not semi-infinite but is restricted to a particular thickness.

2.6 Effect of Rigidity of Footing

Whitman and Richart (1967) proposed settlement influence factor, β_z , for rigid footings on a semi-infinite homogeneous layer of soil for rectangular footings of different dimensions to determine the settlement values. The factor, β_z , depends on

the aspect ratio, L/B of the footing. Sovinc (1969) proposed the solutions for a rigid footing on a finite layer of soil by proposing a settlement factor β , where β depends on the aspect ratio, L/B, and the normalised thickness of the layer with respect to the length of the footing, H/L.

The US Navy Soil and Foundation design manual (1986) has also proposed the settlement influence factor for both semi-infinite and finite layer of soil. They have given the settlement factors for both rigid and flexible footings at the centre and the corners for rectangular footing for various dimensions. In the case of finite layer of soil, the values proposed are for Poisson ratio of either 0.33 or 0.5.

2.7 Depth of Embedment of Footing

Groth and Chapman (1969) proposed influence factor for vertical settlement at the corner of a rectangular footing on a semi- infinite layer for a footing embedded at a depth of h as given in Equation 2.12 where I is the influence factor.

$$\rho_z = \frac{pB(1-\nu^2)}{E} I \quad \dots\dots\dots(2.12)$$

where,

$$I = K_0 \left[K_1 \left\{ \beta \ln \left(\frac{1+\sqrt{1+\beta^2}}{\beta} \right) + \ln(\beta + \sqrt{1 + \beta^2}) \right\} + K_2 \left\{ \ln \left(\frac{\beta+t}{\sqrt{1+4\alpha^2\beta^2}} \right) + \beta \ln \left(\frac{1+t}{\beta s} \right) - 2\alpha\beta \tan^{-1} \left(\frac{1}{2\alpha\beta} \right) + 4\alpha\beta \tan^{-1} \left(\frac{(1-s)(\beta s-t)}{2\alpha} \right) \right\} + 2\alpha\beta K_1 \tan^{-1} \left(\frac{1}{2\alpha t} \right) + \frac{8\alpha^4\beta t}{s^2(1+4\alpha^2t^2)} \cdot \left\{ 2 + \frac{1}{4\alpha^2} - \frac{1}{t^2} \right\} \right]$$

$$K_0 = \frac{1+\nu}{8\pi(1-\nu)} , K_1 = 3 - 4\nu,$$

$$K_2 = 5 - 12\nu + 8\nu^2,$$

$$\alpha = \frac{h}{b} , \beta = \frac{b}{a},$$

$$s = \sqrt{1 + 4\alpha^2},$$

$$t = \sqrt{1 + \beta^2(1 + 4\alpha^2)}$$

Fox (1948) proposed a relationship between the mean vertical settlements at a depth of a rectangular footing to the mean vertical settlement if the same footing is placed on the surface. The depth factor represented in terms of $\frac{h}{\sqrt{ab}}$ and $\frac{\sqrt{ab}}{h}$ and was plotted against $\frac{\rho_{mo}}{\rho_m}$ for various b/a value. The parameters defined are, h is the depth of embedment, a is the longer side of the footing, b is the breadth of the rectangular footing, ρ_m is the settlement at a depth, ρ_{mo} is the settlement at the surface of the soil for a Poisson's ratio of 0.5.

Burland (1970) proposed a correction factor I_E for taking into consideration the depth of embedment of the footing for a footing embedded in a semi-infinite layer of soil as represented in Equation 2.13. The variables in the equation are z_e is the depth of embedment depth, ν is the Poisson's ratio and d is the diameter of the footing.

$$I_E \approx 1 - \frac{1}{3.5 \exp(1.22\nu - 0.4) \left[\left(\frac{d}{z_e} \right) + 1.6 \right]} \dots\dots\dots(2.13)$$

All the above solutions proposed by various researchers, as stated above, the solutions for the required problem definition is not available or is limited to approximations for limited cases. For the profile defined by two layered soil system underlain by a rigid base, solutions need to be proposed to correctly define the settlements obtained and also study the extent of settlement by studying the profile of settlements at the surface.

Chapter 3

Modelling in PLAXIS 3D

3.1 Introduction

PLAXIS is two or three-dimensional finite element software, developed for geotechnical applications in which models are created using finite elements to simulate soil behaviour. PLAXIS has both 2D and 3D software for specified uses. The problem defined before is for a rectangular footing on a two layered soil system. The rectangular loading is asymmetric in both the x and y direction and therefore the settlement profiles will also differ. The problem cannot be summarized to a 2D problem. The entire modelling on this paper is based on PLAXIS 3D software unless specifically mentioned. The in-built program uses factors for loads and models parameters based on applicable ultimate limit state design method, in addition to serviceability limit state calculations. The analysis covered in this thesis is based on workable conditions of the footing, i.e. the footing is still considered working and the soil is assumed to still be in the elastic state and therefore the soil model adopted is linear elastic model. Linear state considers that the soil is still in elastic equilibrium i.e. as the load is removed, the soil comes back to its initial state. This chapter deals with the assumptions dealt in modelling the problem definition defined in Chapter 2. It also covers the convergence study and the boundary conditions adopted. (PLAXIS general manual)

3.2 Problem Definition

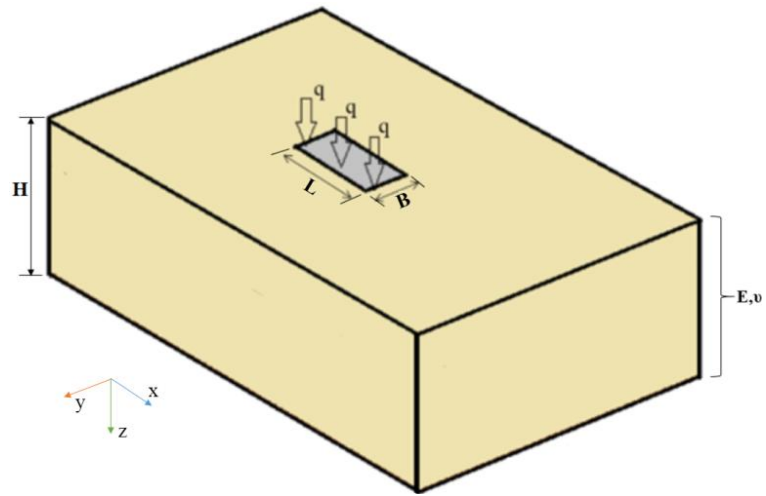

Figure 3.1. Representative model of rectangular footing on finite layer of soil

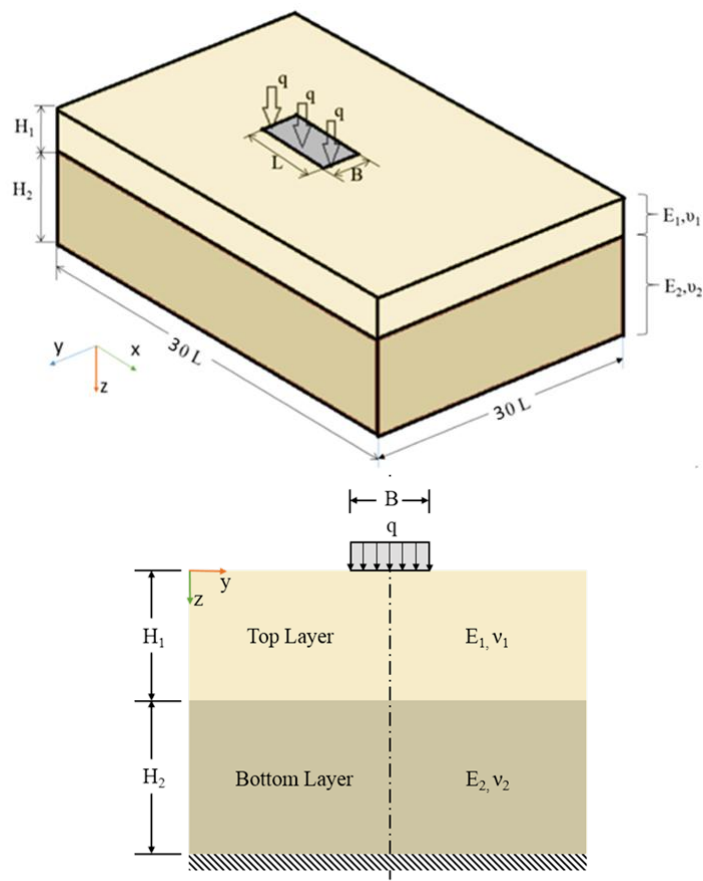

Figure 3.2. Representative model of rectangular footing on two layered soil system

A uniform rectangular load of intensity 'q' acts on soil system. The rectangular loaded area is defined by the dimensions L and B. Figure 3.1 shows the representative model for a finite soil layer with thickness of H on which a rectangular load is applied on the surface. Figure 3.2 shows the system with two layers of soil underlain by a rigid base with the thicknesses of the top and bottom layers as H_1 and H_2 , respectively. The objective of the study is to analyse the maximum settlement influence factors at the centre of the footing. The settlement of a shallow footing depends on various other factors like shape of the footing, depth of embedment and rigidity of the footing apart from the load on the footing. Influence factors are introduced to include the effects of the factors influencing the settlement independent of the other influencing factors. In addition, the settlement profiles in both x and y directions are also presented.

3.3 Finite Element Analysis

Finite Element Analysis is a method to find numerical solution for complex existing problems in the real world using approximations and solving differential equations. As with all numerical solutions, error due the approximations occurs, however the error can be limited by understanding how finite element is implemented in the particular software and also through experience. The method utilises breaking the model into smaller components called finite elements connected through node points and creating a solution by the approximated differential equation used for defining the problem by the application of pertinent boundary conditions. Displacements are found at the nodes while the stress variation is computed and represented at the stress points. Care was taken to cross check if the angle at the corners of the finite elements were between 30^0 and 120^0 for getting better results.

3.4 Advantages of PLAXIS 3D

With various software based on FEA available commercially, PLAXIS is one of the few three dimensional software available specifically designed for geotechnical purposes. Modelling is divided into profile creation of soil, application of soil model, addition of structural components, meshing, and water table, followed by the calculation. Pre-defined soil models and soil sample data are available in-built in the

software. However provision for used defined modelling is also available. PLAXIS has both 2D and 3D software. Since the model has rectangular footing as structural component which is not symmetric, we adopt 3D software in our study to study the effects on all three directions, x, y and z. Quadratic tetrahedral 10- noded elements are available in PLAXIS 3D for meshing into finite elements. The software also has the option of automated mesh generation with options for global and local refinement of the model.

3.5 Finite Elements

Finite Elements are elements obtained by splitting the model into finite number of parts for approximation purposes. PLAXIS 3D uses quadratic tetrahedral 10- node elements as shown in Figure 3.3. Quadratic tetrahedral 10- node elements are linear stress elements with 10 nodes. The elements are generally formulated in 3D modelling. It has three degree of freedom per node translating in x, y and z direction. These are iso-parametric elements with stresses being calculated at stress points and displacements in nodes. The elements are generally used for loading in three directions or uniform pressure on element surfaces. It gives defined results of stress through thickness of the model, has forces as input and not as moments (lacks rotational degrees of freedom) and has pressure load applied. These validate using the elements in the required modelling. The element has various advantages including better stress analysis and is favoured in 3D mesh generation as it allows curved surfaces and sides. The disadvantages include complicated formulation, increased formation time when compared to lower degree elements.

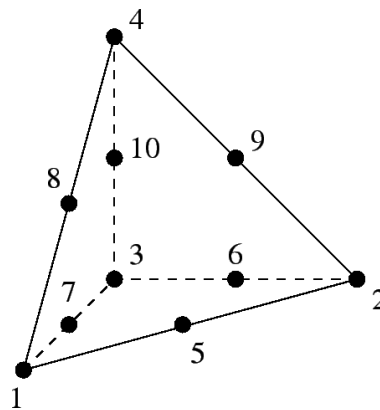

Figure 3.3. Representative model of a 10-noded tetrahedral model used in PLAXIS 3D software

3.6 Soil Model

The material model used in all the simulations in the thesis is linear elastic material model. Technically, the use of linear elastic material model is restricted to the cases only if the strain in the material is small, the stress component is linearly proportional to the strain, the material returns back to its original shape with unloading have the same path as the loading path and there is no dependence on the rate of load applied or the time taken for loading or unloading. As the study of the soil deals with the elastic behaviour of the soil and the soil loading is not dependent on time and the loading path. Therefore the selected material model is sufficient for the model defined. Figure 3.4 shows the linear elastic perfectly plastic model corresponding to the behaviour of the Mohr-Coulomb model. The plastic behaviour of the soil is omitted due to the consideration that the load applied is the working load and only results are observed only till the soil remains in elastic condition, as primary settlements are only considered.

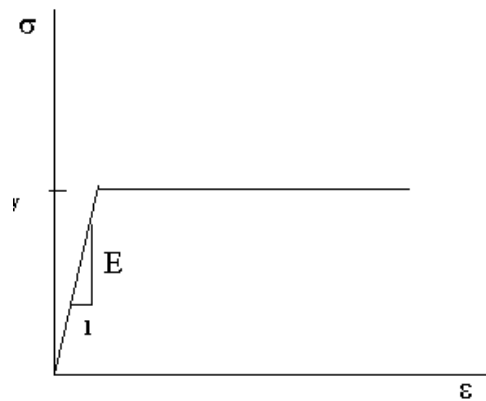

Figure 3.4. Representation of Linear Elastic- Perfectly Plastic model

3.7 Boundary Conditions

PLAXIS 3D has pre-defined default boundary conditions. The automated boundary condition defines that the displacement on the surface is free in all directions, and at the bottom of the model is fixed in all directions ($u_x=u_y=u_z=0$), the displacements

along x direction of the software is fixed on the y direction and the displacements along y direction has its displacements at the boundary fixed in the x direction and free in all the other directions. The models in the thesis all use automated boundary condition.

3.8 Convergence Study

Convergence study was done both for the boundary distance and the meshing of the model. Based on the convergence study the fine refinement was chosen where the element size is 0.7 times the automated meshing dimensions where the average element size is approximately 5.9m. However the fine refinement did not give a clear idea on the vicinity of the application of the load. The model dimensions were considered as 30 times the length of the footing ($30L$) for convergence. The convergence, in general, for the dimensions of the model for a footing will be 25 times the length of the footing. However for a very thin layer of top layer of soil with very high of low E_1/E_2 values, the distribution exceeds the general guidelines. Analysing for the worst case scenario, the boundary condition of 31 times the length, L , of the footing has been considered. Figure 3.5 indicates the extent of the boundary in both the directions as shown from top view.

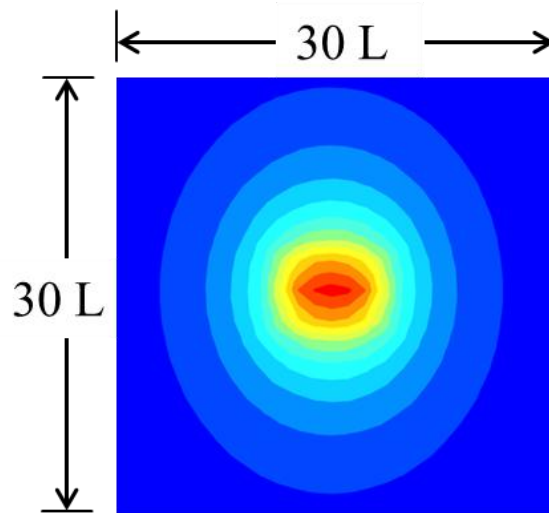

Figure 3.5. Extent of boundary in both the directions (top view)

3.9 Meshing

For calculation using finite element method, the model is subdivided into elements by the process of meshing. The whole model is subdivided into elements by automated meshing. 10 node triangular elements are used in the modelling. Convergence study was performed for both the meshing and the model dimensions. Global refinement was adopted as fine where the model relative size is 0.7 compared to 2 for very coarse refinement. The average element size was about 5m but varies depending on the size of the model without considering local refinement. Local refinement was adopted around the loading areas as explained below.

3.9.1 Refinement of Surfaces

As automated meshing and global refinement yields a mesh with element size of approximately 5m. However the size of the footing was approximately the size of one element. Multiple elements are desired below the footing to correctly predict the behaviour of the soil to the load applied. Therefore surface local refinement was adopted to refine the mesh further. A local refinement of 0.125 times the size of the global refinement was adopted to reduce the size of the elements below the footing to 0.6m.

3.9.2 Volume Refinement

Figure 3.6 (a) shows the model with local surface and global refinement while figure 3.6 (b) represents the same with local volume refinement. As represented, the elements are comparatively large to accurately represent the displacements or the displacement profiles on the surface. Comparing with the local refinement, the profiles to be plotted still didn't give a perfect impression of the settlement on the surface. Therefore a local volume refinement was considered around the area of the application of the load. An area of 3m around the load was considered for volume refinement and the local area was refined to 0.125 times the size the general area of the model.

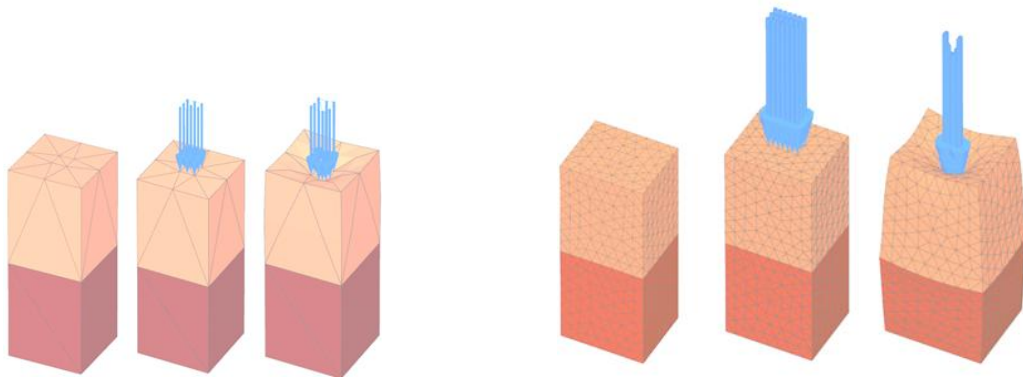

Figure 3.6. Model around the loading with rectangular loading (a) without local refinement (b) with local refinement

Chapter 4

Poisson's Ratio Effect

4.1 Introduction

Poisson's ratio is the ratio of the transverse contraction strain to the longitudinal extension strain in the direction of the tensile force applied. Poisson's ratio has relation with the elastic modulus and shear modulus. The theory of isotropic linear elasticity allows Poisson's ratio to range from 0 to 0.5 in soils. Results from tri-axial tests results in the Poisson's ratio of the soil generally ranging from 0.25 to 0.45. However, errors in tri-axial tests like end effects, stress non-uniformity, capping and seating led to erroneous values being reported. Improvement in testing methods and equipment has led to more accurate values being reported ranging from 0.01 to 0.2. The normal range of values to be used in elastic continuum for soils in drained conditions therefore generally vary from 0.1 to 0.2 for all types of soils. Poisson's ratio of 0.5 is still valid for un-drained conditions.

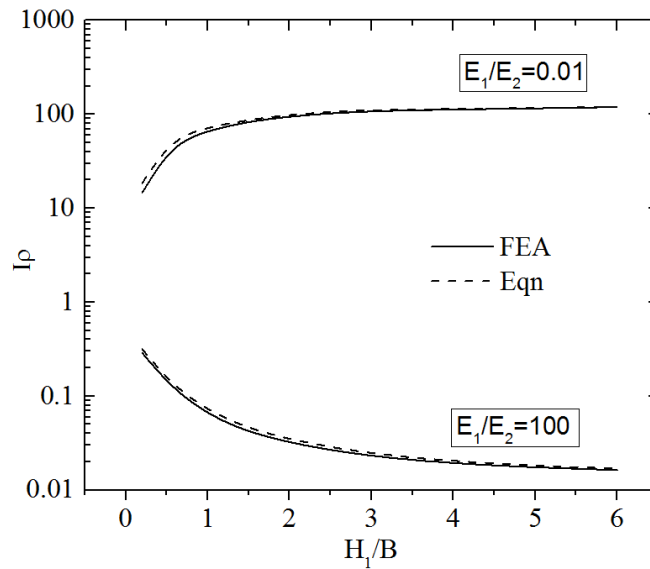

Figure 4.1. Comparison between Finite Element Analysis and approximation using Razouki's proposition

The results proposed in the thesis are generally for Poisson's ratio of 0.2 with an exception for the settlement influence factor of the soil for a flexible rectangular loading where the results are also given for Poisson's ratio of 0.35. However, the results for other Poisson's ratio can be approximately derived from the results proposed for Poisson's ratio of 0.2.

4.2 Equivalent Settlement factors for Poisson ratio

From Equation 2.1 of the Boussinesq's equation, the relation for the elastic settlements with Poisson's ratio is given. Applying the range of values of 0.1 to 0.2 as suggested by Mayne (1999), the term $(1-\nu^2)$ is reduced to 0.99 to 0.96 not altering the original value of the settlement. However, to find the exact value change due to Poisson's ratio, an approximation is proposed by Razouki (2009) as given in equation 4.1.

$$I_v = \frac{(1-\nu_a^2)}{(1-\nu_u^2)} \dots\dots\dots(4.1)$$

The effect of converting the values using the formula mentioned by Razouki was studied for a two layered soil system in this chapter for a rough footing. Figure 4.1 shows the comparison of values between results obtained for a Poisson's ratio of 0.2 from Finite Element Analysis using PLAXIS 3D and the results obtained using the

same model for a Poisson's ratio of 0.35, converted to 0.2 using equation 4.1. The results obtained were in good agreement for Poisson's ratio conversion. This method is found satisfactory for converting Poisson's ratio provided the two layers have the same Poisson's ratio.

The conversion effect is valid though generally unnecessary as the effect of Poisson's ratio is minimised when the soil is considered linear elastic. The thesis therefore considers results only for Poisson's ratio of 0.2. Results for any other Poisson's ratio can be interpolated from the formula. An example of conversion is given for reference.

4.3 Example Problem

For a rigid rectangular footing on a two layer soil system underlain by a rigid base with $E_1/E_2=0.5$, $L/B=2$, $H_1/B=1$, $H_2/B=4$ and $\nu=0.2$, the settlement influence factor is given as 1.538. Here assumed Poisson's ratio is 0.2 and to find the settlement influence factor for Poisson's ratio of 0.15 for the same soil properties,

ν_a = assumed Poisson's ratio = 0.2

ν_u = assumed Poisson's ratio = 0.15

$$I_v = \frac{(1 - \nu_a^2)}{(1 - \nu_u^2)} = \frac{(1 - 0.2^2)}{(1 - 0.15^2)} = \frac{(1 - 0.04)}{(1 - 0.0225)} = \frac{0.96}{0.9775} = 0.982$$

The settlement influence factor for the model with Poisson's ratio of 0.15 is now $1.538 * 0.982 = 1.511$.

Chapter 5

Settlement due to Uniform Rectangular Footing on Two Layered System

5.1 Introduction

Rectangular footings cannot be represented as two-dimensional problems in general due to the lack of symmetry in both the directions. The results in the x direction and the results in the y direction do not offer the same results. The lack of symmetry further complicates the study of two layer system as the soil is neither homogeneous nor isotropic. In a similar way, the contour of settlements on the surface is also not uniform in both the directions and cannot be assumed to be considered from just the width of the footing. The depth of influence is principally governed by the dimensions of the footing. However in the case of a two layer soil system, the depth of influence is governed by influence of the relative stiffness of the layers and the thickness of both the layers exclusive of the dimensions of the footing. The influence of the elasticity on the settlement of the rectangular footing is studied in terms of normalised factor, E_1/E_2 , where E_1 and E_2 are the stiffness of the top and the bottom layer respectively. The analysis for rectangular footing for two layer soil system is done for three aspect ratios, L/B , of 1, 2 and 5. Results are obtained in terms of settlement influence factors and surface settlement influence factor profile and the influence of stiffness, thickness and the aspect ratio of the footing.

5.2 Problem Definition

A uniform rectangular load of intensity 'q' acts on a two-layered soil system underlain by a firm stratum. The rectangular area of load is defined by the dimensions L and B. The thicknesses of the top and bottom layers are H_1 and H_2 ,

respectively. The objective of the study is to analyse the maximum settlement influence factor at the centre of the footing and also investigate the surface settlement profiles as a product of surface settlement values and normalised values of corresponding dimension i.e., the profile along the length is plotted against the normalised length i.e. x/L . The profile is plotted in both the x and y direction for understanding the influence of the load.

5.3 Validation

The stability and the usability of the software can be confirmed by the validation of the results by previously obtained and recorded data points. The results detailed below in the next section are validated by the data obtained by two case studies in Australia and Canada. The results are consistent with that obtained by the FEA.

5.3.1 Case Study 1- Savings Bank, Adelaide, Australia

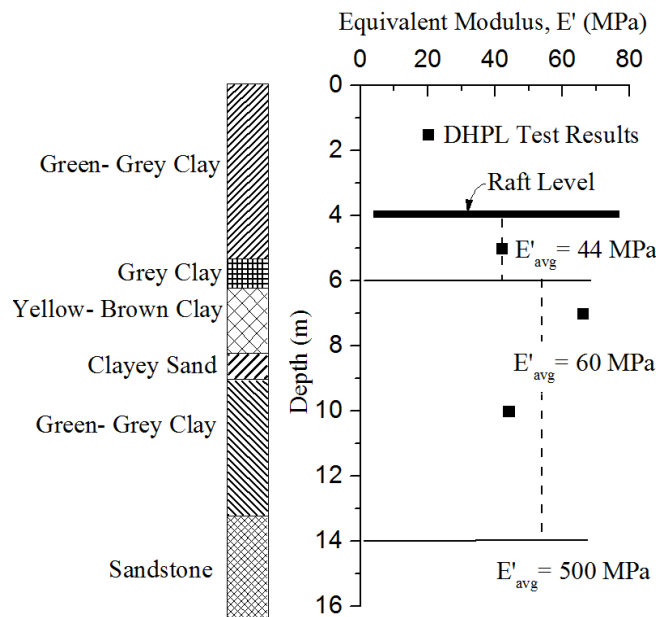

Figure 5.1. Soil Profile at Savings Bank, Adelaide, Australia

Kay and Cavagnaro (1983) reported measured settlements of three buildings located in Adelaide, Australia. One of the buildings consisted of a Savings Bank supported on a raft footing of length and width equal to 39.5 m and 33.5 m, respectively. Raft was placed at a depth of 4 m from the ground surface, and was subjected to a load of

intensity equal to 134 kPa. The soil profile at this site comprised predominantly of clay layers overlying a sandstone deposit. The water table was located at a depth of 20 m below the ground level, such that it doesn't bode much influence over the settlements of the footing. Down Hole Plate Load (DHPL) tests were conducted to obtain the drained deformation modulus, E' , of the soils layers at the site. Based on the deformation modulus measurements, the soil profile underneath the footing may be assumed to be made up of a two-layered soil system followed by a stiff sandstone layer with equivalent E' values equal to 44 and 60 kPa (Figure 4), similar to the basic model considered in this study (Figure 2). The thickness of the top layer was taken as 2 m, while the second layer extended 8 m below the top layer. The Poisson's ratio equal to 0.2, an appropriate value for Adelaide soils, was considered as mentioned by the authors (Kay and Cavagnaro, 1983). Settlement equal to 22 mm was measured at the centre of the footing, while settlements equal to 11 mm, 7 mm, and 5 mm were measured at the centre of the edges of the footing and at the corner of the footing, respectively. The corresponding settlements from the finite element model used in the present study were obtained as 21.9 mm, 10.6 mm, 4.6 mm and 5.5 mm, respectively. The results obtained from finite element model are in good agreement with the measured values. The table 5.1 shows the settlements as measured by Kay and Cavagnaro, predicted settlements using PLAXIS 3D and the percentage of variation at various locations of the footing.

Table 5.1. Settlements as measured by Kay and Cavagnaro and predicted settlements using PLAXIS 3D

Method	Centre Settlement (mm)	Edge Settlement (mm)	Uniform Settlement (mm)
Predicted Settlement- Finite Layer	22.7	5.6	19.9
Predicted Settlement- Two Layer System	25.9	-	19.9
Measured Settlement- Field Value	21.9	5.5	-

5.3.2 Case Study 2- Leaside Towers, Ontario, Canada

Trow and Bradstock (1972) studied the settlement of caisson and raft foundations for Leaside Towers in Metro Toronto, Ontario, Canada. It is a 43-storeyed structure consisting of two towers, one tower is supported on a caisson foundation and the other on a raft foundation. In this study, the settlement of raft foundation is considered to validate the finite element model. Raft consisted of three parts connected to each other by construction joints and was placed at a depth of 5m from the ground surface. The raft footing was founded on 4m-thick medium sand underlying 13m-thick clayey silt till and 17m-thick silt and silt till deposit below the level of the footing. Figure 5c shows the soil profile at the site along with the equivalent deformation modulus of the soil layers. The deformation modulus of the soil layers are obtained based on the method proposed by Fraser and Wardle (1976) as suggested by Enkthur. Due to relatively small thickness of the medium sand deposit below the footing, the raft may be assumed to rest directly on the two-layered soil system consisting of 13m-thick clayey silt till and 17m-thick silt and silt till deposits, underlain by a bedrock. The maximum settlement of the raft footing was interpolated from the measured settlements values and was obtained as 39.3 mm. Considering the dimensions of the raft foundation, we have obtained the ratios as $L/B = 2.72$, $H_1/B=0.5$, $H_2/B=0.54$ and $E_1/E_2=0.502$. The value of Poisson's ratio of soil layers was assumed to be equal to 0.25 (Enkthur et al. 2013). The maximum settlement equal to 36.6 mm was obtained from the finite element model considered in this study, a difference of 7% from the measured value. This could be due to assumed to be the settlement of 1m-thick medium sand deposit that was ignored in the finite element model. In addition, the raft consisted of three parts connected by construction joints, while it was assumed to be a single raft in finite element modeling.

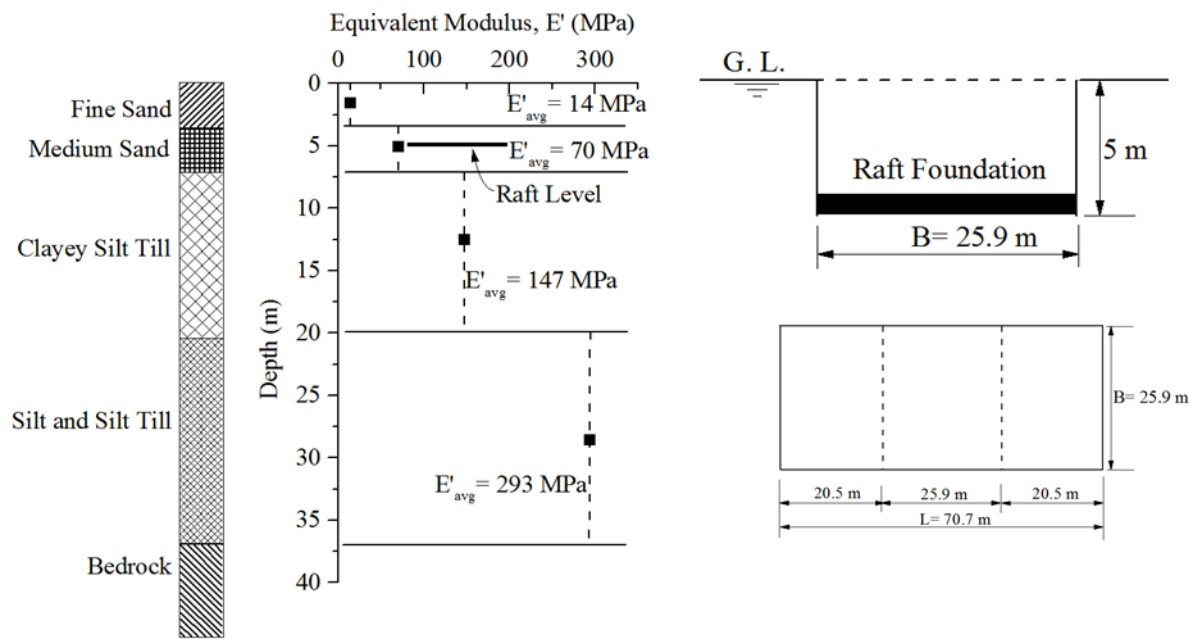

Figure 5.2. Raft details and soil profile for Leaside Towers, Ontario, Canada: (a) cross section of the footing, (b) plan view of the raft foundation, and (c) soil profile with deformation modulus of soil layers (modified after Trow and Bradstock 1972)

The settlement of layered soil system from the finite element model was found to compare very well with the measured settlement of footings reported in the two case studies. The same finite element model was used to further carry out an extensive parametric study. Based on the finite element analysis, the settlement influence factors were deduced and presented for a wide range of geometric and elastic properties of the layered soil system. Results in the form of charts and the effects of various parameters on the maximum settlements and surface settlement profiles for rectangular loading are discussed next.

5.4 Maximum Settlement Influence Factors

Figures 5.3 to 5.6 show the variation of maximum settlement influence factor, $I_{p,max}$, with H_1/B for $L/B=1, 2$ and 5 and corresponding to $H_2/B=1, 2,$ and 4 . These charts can be used to estimate the immediate settlement at the centre of rectangular load acting on a two-layered system underlain by a firm stratum. The effects of

thicknesses of top and bottom layers, loading area, and deformation modulus of two layers are given in terms of normalized parameters - H_1/B , H_2/B , L/B and E_1/E_2 .

5.4.1 Effect of Poisson's ratio

For the two values of Poisson's ratio, $\nu_1=\nu_2=0.2$ and 0.35 considered in the study, the settlement influence factor was found to decrease slightly with increase in the Poisson's ratio. However, the effect of Poisson's ratio on the settlement of layered system can be considered insignificant (Figures 5.3 to 5.6).

5.4.2 Effect of H_1/B

For the given geometry of the soil layers, the settlement below the uniform rectangular area increases with decrease in the moduli ratio, E_1/E_2 (Figures 5.3 to 5.5). This can be explained based on the vertical stress distribution within the two-layered system due to loading. Figure 5.6 shows the vertical stress distributions for three moduli ratios, $E_1/E_2 = 0.01, 0.5,$ and 100 , and corresponding to $L/B=1$, $H_1/B=1$, and $H_2/B=4$. For the case of $E_1/E_2=100$ (Figure 5.6(c)), the vertical stress bulb corresponding to $0.1q$ (10% of applied load) is mostly confined to top stiff layer and negligible stresses are transferred to the bottom softer layer. While for the case of $E_1/E_2=0.01$ and 0.5 (Figures 5.6 (a) and 5.6(b)), the top softer layer is subjected to significant vertical stresses. Hence, the settlements are higher for the case with lower E_1/E_2 than that with higher E_1/E_2 for given thicknesses of the soil layers.

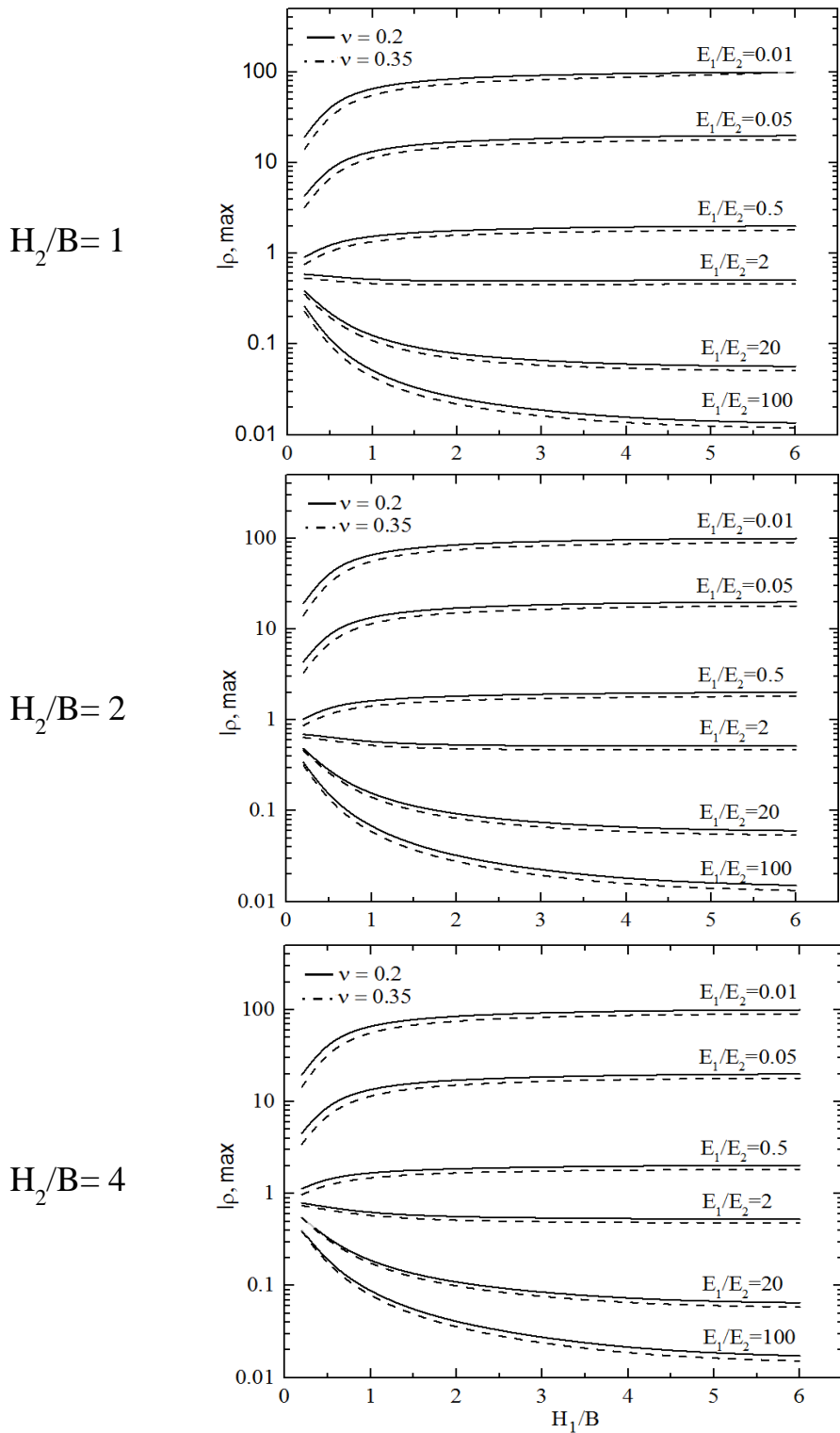
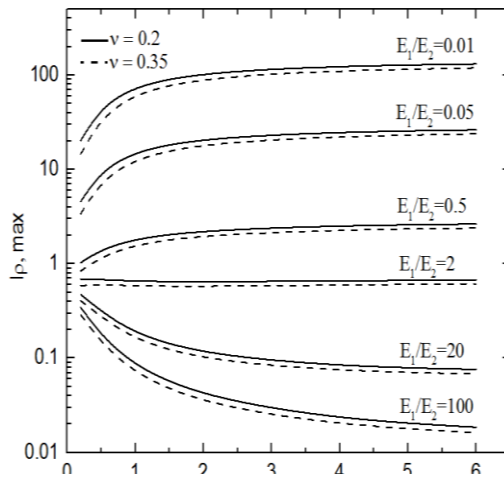
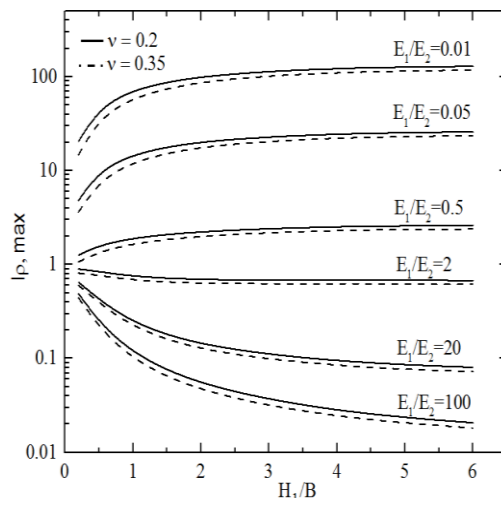

Figure 5.3. Variation of maximum settlement influence factors with H_1/B for $L/B=1$, $H_2/B=1, 2$ and 4 corresponding to $\nu=0.2$ and $\nu=0.35$ and $E_1/E_2=0.01, 0.05, 0.5, 2, 20$ and 100

$H_2/B=1$



$H_2/B=2$



$H_2/B=4$

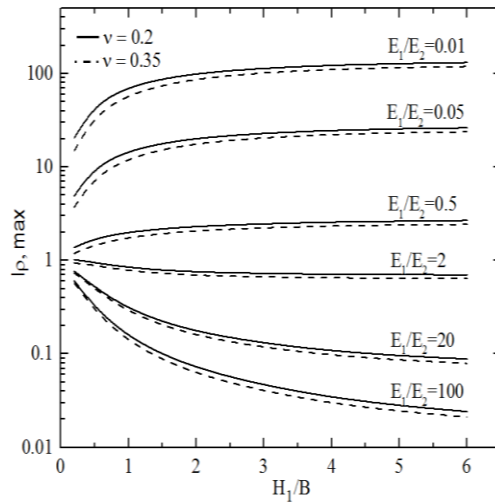

Figure 5.4. Variation of maximum settlement influence factors with H_1/B for $L/B=2$, $H_2/B=1, 2$ and 4 corresponding to $\nu=0.2$ and $\nu=0.35$ and $E_1/E_2=0.01, 0.05, 0.5, 2, 20$ and 100

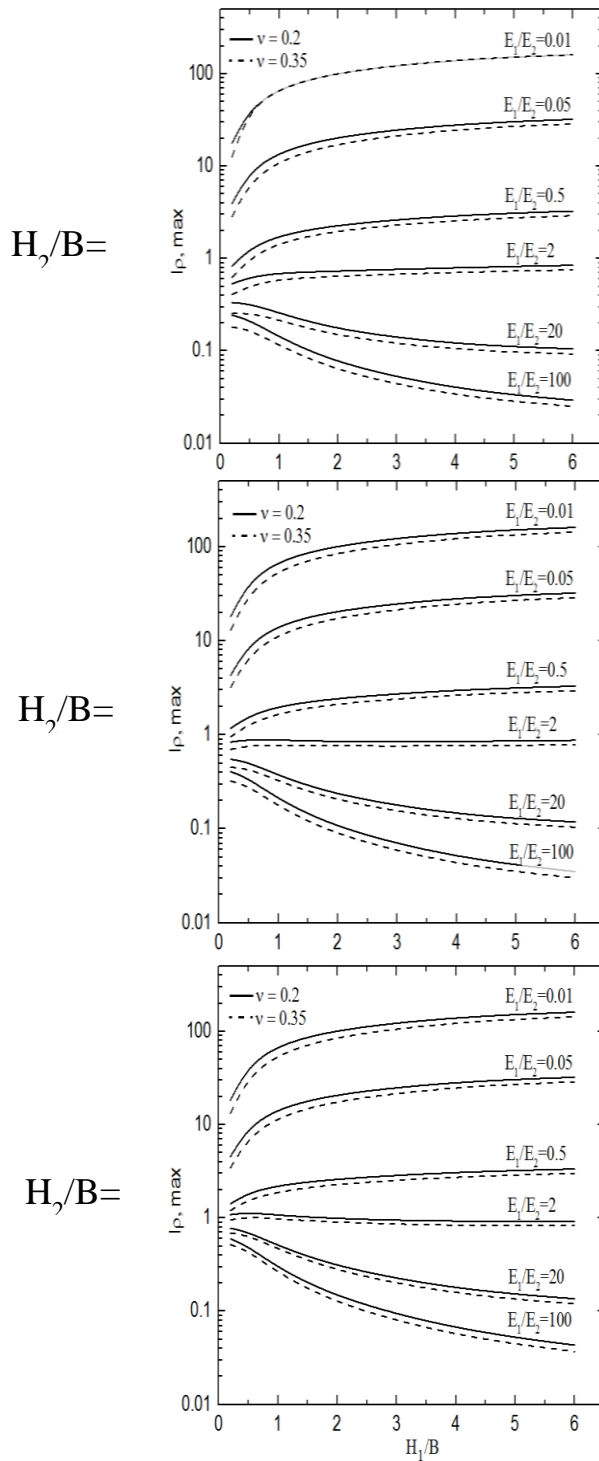

Figure 5.5. Variation of maximum settlement influence factors with H_1/B for $L/B=5$, $H_2/B=1, 2$ and 4 corresponding to $\nu=0.2$ and $\nu=0.35$ and $E_1/E_2=0.01, 0.05, 0.5, 2, 20$ and 100

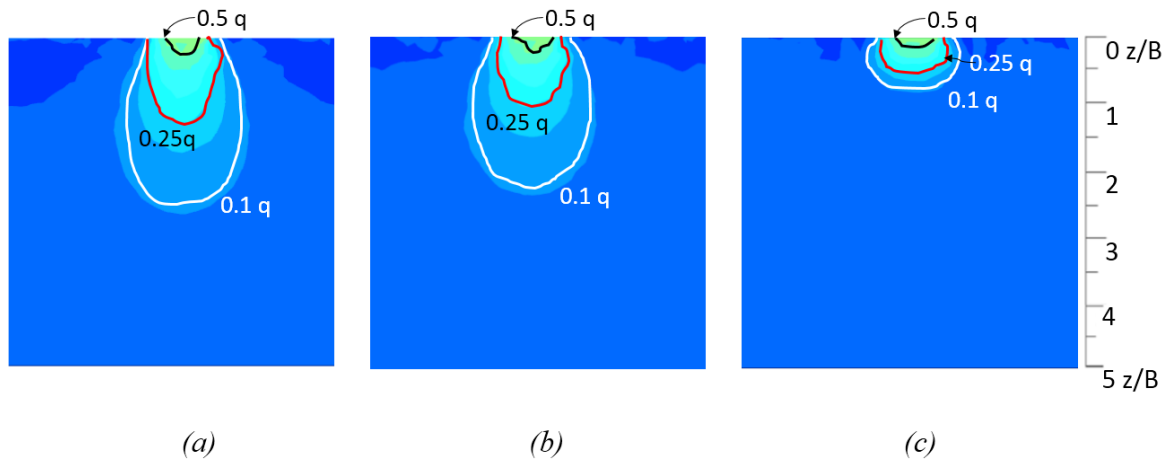

Figure 5.6. Vertical stress distribution due to a rectangular loading for $L/B=1$, $H_1/B=1$, $H_2/B=4$, $E_1/E_2=0.01$ and corresponding to (a)

(b) $E_1/E_2=100$ and (c) $E_1/E_2=100$ (z indicates the depth as given in Figure 2)

For a given L/B and H_2/B , the maximum settlement influence factor, $I_{p,max}$, decreases with H_1/B for $E_1/E_2 > 1.0$ and increases with H_1/B for $E_1/E_2 < 1.0$ before reaching a plateau. The rate of change in the maximum settlement influence factor, $I_{p,max}$, decreases with increase in H_1/B . When the bottom layer falls within the influence depth of loading, the modulus of the bottom layer will have a bearing on the settlement of the layered system. The top layer is likely to fall within the influence depth for small thickness of the top layer (i.e. low H_1/B values), thus effecting significantly the settlements under the load. However, the effect of H_1/B will be insignificant for higher H_1/B values that exceed the influence depth of the loading. From Figures 5.3 to 5.5, the thickness of the top layer was found to have significant effect on the settlements for H_1/B within about 2.5. For example, for $E_1/E_2=0.01$ and $H_2/B=1$, the percent increase in $I_{p,max}$ is equal to 54% for H_1/B increasing from 0.5 to 1.0, while the increase is only 2% for H_1/B increasing from 4.0 to 6.0 (Figure 5.3(a)). Similarly, for $E_1/E_2=100$ and $H_2/B=1$, the percent decrease is 50% and 0% as H_1/B increases from 0.5 to 1.0 and from 4.0 to 6.0, respectively.

5.4.3 Effect of H_2/B

Figure 5.7 shows the variation of maximum settlement influence factor, $I_{p,max}$, with the bottom layer thickness ratio, H_2/B . For relatively small thickness of the top layer, $H_1/B=0.5$, the bottom layer has a significant influence on the settlement of layered system for thickness up to $2.5B$ (i.e., $H_2/B < 2.5$). For example, $I_{p,max}$ increases by 36% and 13% corresponding to $E_1/E_2=20$ and 0.5 as H_2/B increases from 1.0 to 2.0. While the corresponding increase is only 10% and 4% as H_1/B increases from 3.0 to 4.0. However, for the case of a relatively thick top layer, the effect of thickness of bottom layer on the settlement of layered system is found to be negligible. The increase in $I_{p,max}$ is within 10% as H_2/B increases from 1.0 to 6.0 when top layer is relatively thick (i.e., $H_1/B=4.0$).

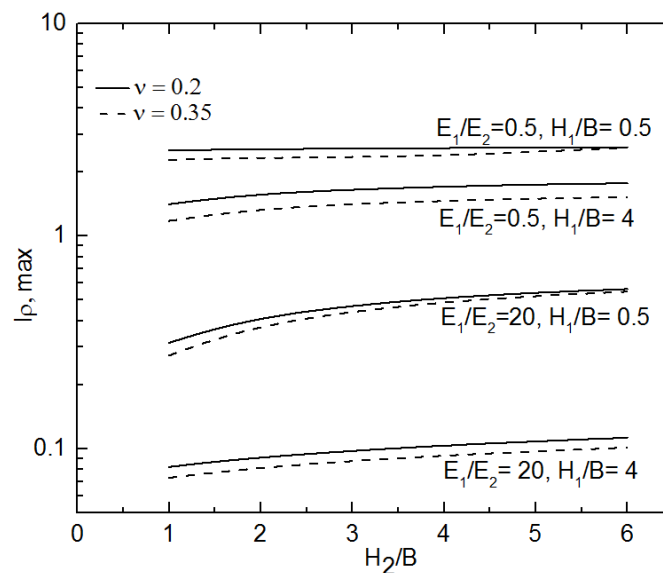

Figure 5.7. Variation of maximum settlement influence factors with H_2/B for $L/B=2$ corresponding to $H_1/B=0.5$ and 4.0 , $E_1/E_2=0.5$ and 20 and $\nu=0.2$ and 0.35

5.4.4 Effect of L/B

Figure 5.8 shows the variation of the maximum settlement influence factor, $I_{p,max}$, with L/B . The influence depth increases with increase in L/B and hence, the settlement under loaded area of the two-layered system increases with increase in L/B . However, L/B is found to have

significant effect on the settlement for L/B ratios up to 2.5. For higher L/B ratios (L/B > 2.5), the effect is found to be insignificant. Figure 17 shows the variation of the maximum settlement influence factor with L/B for H₁/B=1, H₂/B=4, ν₁= ν₂= 0.2 and 0.35 for E₁/E₂=0.05, 0.5, 2 and E₁/E₂=20. The maximum settlement influence factor increases by 18% and 70% as L/B increases from 1.0 to 2.0 for E₁/E₂=0.5 and 20, respectively. While the increase is only 3% and 2% as L/B increases from 3.0 to 4.0 and corresponding to E₁/E₂=0.5 and E₁/E₂=20.

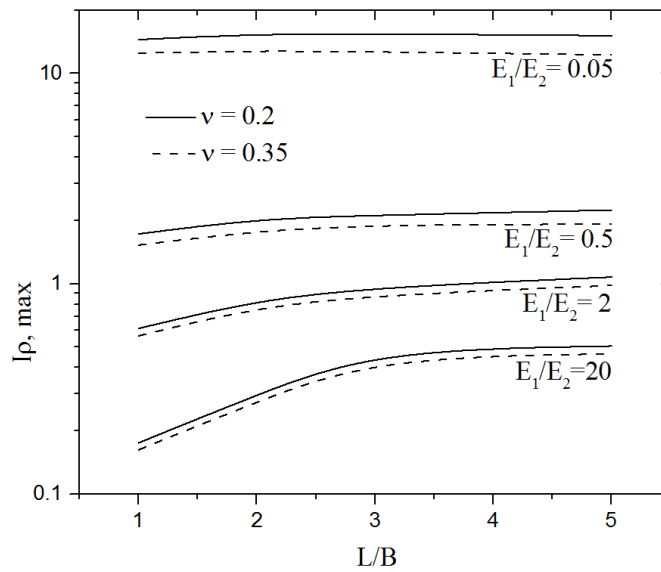

Figure 5.8. Variation of maximum settlement influence factors with L/B corresponding to H₁/B=1.0, H₂/B=4.0, $\nu_1 = \nu_2 = 0.2$ and $\nu_1 = \nu_2 = 0.35$, and $E_1/E_2 = 0.05, 0.5, 2$ and $E_1/E_2 = 20$.

5.5 Settlement Profiles

Settlement induced due to load applied on a footing influences the adjoining structures. The effect of E₁/E₂ on the surface settlements are studied by plotting the variation of settlement influence factors in x and y directions for the case L/B=2, ν₂= 0.2, H₁/B=2 and H₂/B=4. Figures 5.9 to 5.11 shows the settlement profiles for L/B of 1, 2 and 5 in the x and y direction. Figures 5.10 shows the variation of settlement influence factor with x/L for different deformation moduli ratios for E₁/E₂ < 1. The settlements are found to extend to a larger distance for the case with soft layer overlying stiff layer (i.e., decreasing E₁/E₂). For instance, I_p= 1.09 for E₁/E₂ =

0.05, while $I_p = 0.25$ for $E_1/E_2 = 0.5$ corresponding to $x/L=1.0$. The settlements become negligible for $x/L = 2.0$ and 1.0 for $E_1/E_2 = 0.02$ and 0.5 , respectively. Figure 5.10 shows the variation of settlement influence factor with x/L for $E_1/E_2 > 1$. The surface settlements become more uniform with stiff layer overlying soft layer (i.e., high values of E_1/E_2). $I_p = 0.07$ and 0.05 for $E_1/E_2 = 100$, while $I_p = 0.74$ and 0.16 for $E_1/E_2 = 2$ at $x/L = 0.0$ and 1.0 , respectively. Figure 5.10 also shows the variation of surface settlement influence factor with y/B . The variation of settlement influence factor along y direction is found to be similar to that observed along x direction.

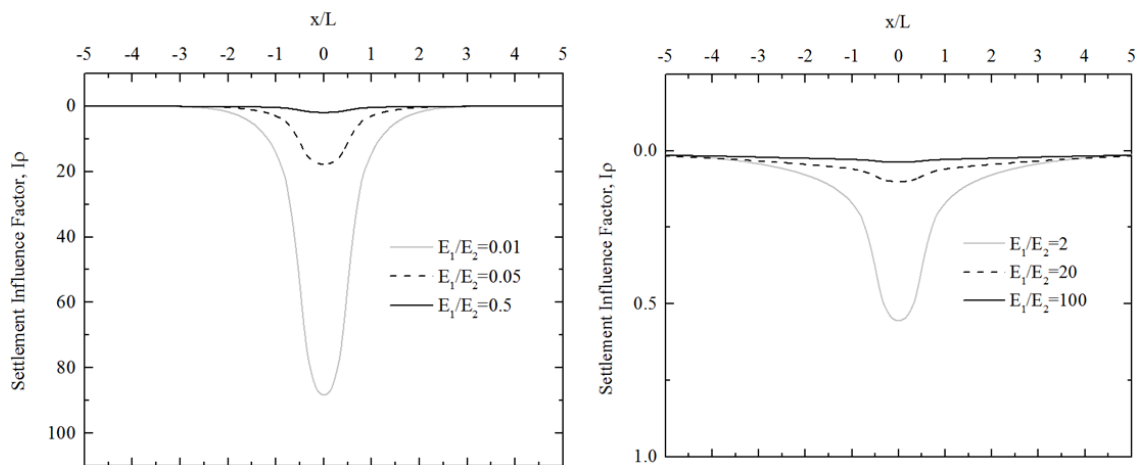

Figure 5.9. Surface settlement influence factors for $L/B=1$, $H_1/B=2$ and $H_2/B=4$ for (a) $E_1/E_2 < 1.0$, and (b) $E_1/E_2 > 1.0$

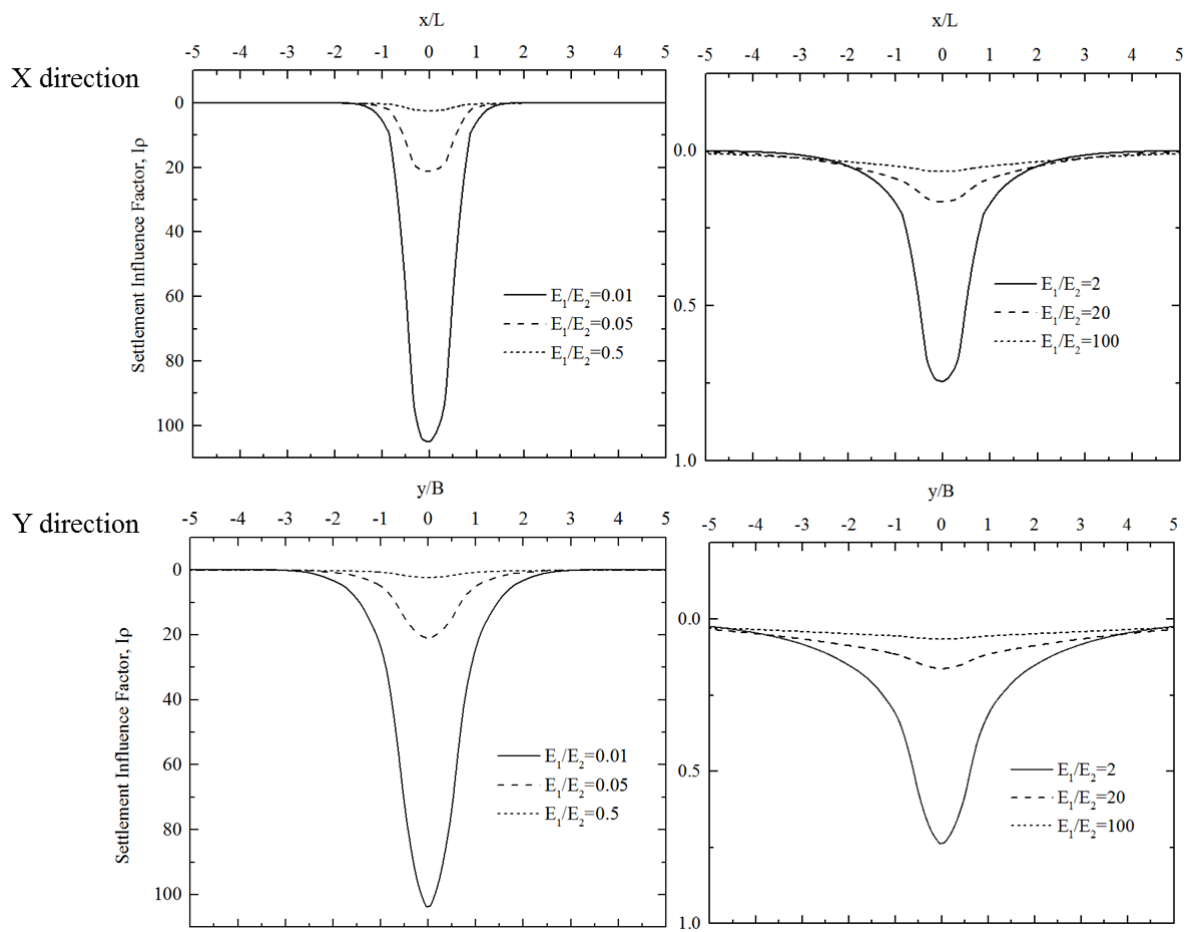

Figure 5.10. Surface settlement influence factors in x and y direction for $L/B=2$, $H_1/B=2$ and $H_2/B=4$ for (a) $E_1/E_2 < 1.0$, and (b) $E_1/E_2 > 1.0$ (x and y is measured from the center of loading)

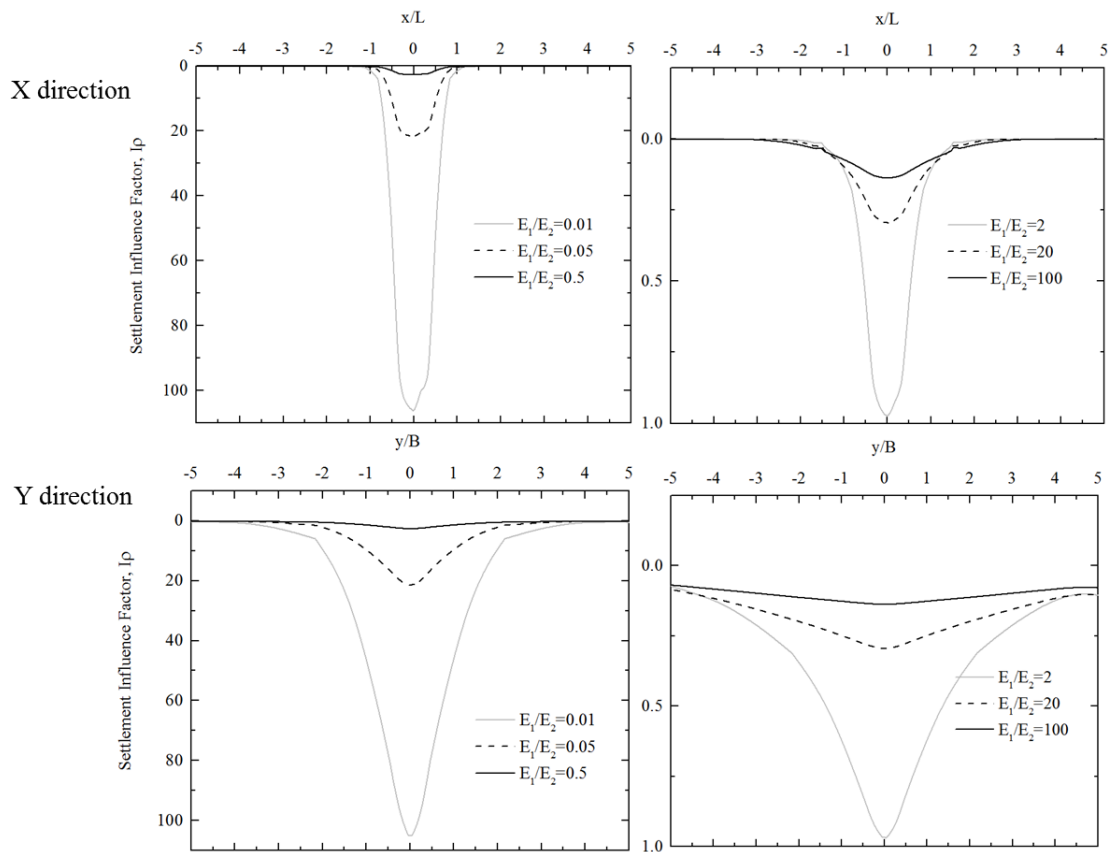

Figure 5.11. Surface settlement influence factors in x and y direction for $L/B=5$, $H_1/B=2$ and $H_2/B=4$ for (a) $E_1/E_2 < 1.0$, and (b) $E_1/E_2 > 1.0$ (x and y is measured from the center of loading)

Chapter 6

Comparison of Settlement of Equivalent Area of Footing

6.1 Introduction

Settlement analysis is one of the foremost considerations for the failure of the structure before construction of the structure. Various studies have proposed methods to compute the settlements for various footings and soil conditions. As Sieffert^[8] however pointed out, due to the presence of various strong computational software, results have been proposed by comparing the values from previous studies, laboratory results or field results. The results present are for a limited area of application and may not be sufficient to be applied for all cases. In case of a rectangular footing, results are limited for analysis of rectangular footing. It has therefore become a common practice to convert area of rectangular footing into equivalent area of footing, typically into square or circular footing. Results published by Razouki^[4] were for square footing lying on a two layer system with the second layer as semi-infinite while Umashankar^[1], proposed settlement influence factors to determine the settlement for a circular footing on a two layer finite system of soil underlain by a rigid base. Entkhur^[2], proposed correction factors for conversion of rectangular footing to equivalent area of circular footing for a semi-infinite layer for L/B less than or equal to 2. They also proposed that if the aspect ratio, $L/B > 2$, then shape conversion gives erroneous results and correction factors should be introduced if shape is modified. The above examples are restricted only to a particular domain of soil condition or thickness of layers and cannot be applied to other footing shapes in all conditions. The authors have proposed or considered

converting rectangular footing to equivalent area of square or circular footing while proposing the settlement influence factors.

Lots of prominent researchers in the field have also mentioned converting loading of other shapes to circular shape with equivalent area and then computed settlement or stress in the soil due to the load. Mayne and Poulos^[7] have recommended conversion of rectangle with sides A and B to a circular of area of $(4AB/\pi)^{1/2}$ for computing the settlements at the center which is also the maximum settlement of the load on the soil. Prakash and Puri^[5] state that in case of non-circular footings, equivalent radius is assumed. Fellenius^[6] mentions that conversion from circular to equivalent rectangular footing is also being carried out and this is also applicable for squares. Chakraborty and Kumar^[3] have proposed the bearing capacity factors for the circular footing and they have mentioned that the bearing capacity factors can also be used as a rough estimation of square footings with equivalent area of circular footing.

Enkhtur^[2] has mentioned that Mayne and Poulos^[7] proposed that for aspect ratio of L/B less than or equal to 2, the conversion of rectangular shape of footing to other shapes gives almost the same result by studying the strain in the soil. The authors had also studied the settlement influence factors for the aspect ratio of L/B greater than 2 and they propose that Mayne and Poulos's proposal overestimates the settlement values and the reason for this is that the diameter of the equivalent footing is larger than the actual breadth of the footing. Enkhtur^[2] also proposed that the actual breadth (or diameter) of the footing needs to be considered instead of the equivalent breadth (or diameter). All the above authors have done research for a semi- infinite soil layer.

This chapter deals with the influence of shape conversion over settlement when the footing is converted from a rectangular footing to an equivalent area of circular or square footing. It also analyses the condition that the soil is not semi- infinite but is restricted to a particular thickness.

6.2 Problem Definition

Two types of soil strata are considered in this study: semi-infinite homogeneous layer of soil and one finite layer of soil underlain by rigid strata. The layer thickness is defined as H and normalized with the breadth and represented as H/B and is varied as $H/B=1, 2, 3, 4$ and 5 in this study. The loading shapes considered in the study were rectangular (and square) and circular. A load q is applied on the soil strata at the centre. The normalized length, L , of the footing is L/B and the equivalent radius of the area of the rectangular footing is established as R_e . A constant Young's modulus, E , of 20 MN/m^2 and Poisson ratio, ν , of 0.2 was assumed throughout the study. The maximum settlement and the extent of the influence of the settlements are computed from the finite element software and a comparison is made for the settlement of the rectangular footing and its equivalent area of circular footing. The equivalent radius was found as proposed by Mayne and Poulos^[7] as stated in the equation below.

$$D = 2 R_e = (4LB/\pi)^{1/2}$$

where, R_e = equivalent radius of the footing, L = length of the footing and B = breadth of the footing

6.3 Results and Discussion

The analysis was carried out and the maximum settlement influence factors and stress distribution contours are discussed for: semi-infinite layer and finite one layer system underlain by a rigid base.

Table 6.1: Maximum settlement influence factors and the percentage of variation between rectangular and equivalent circular footing for a semi- infinite layer

Maximum settlement influence factors and variation in %					
Shape	L/B= 1	L/B= 2	L/B= 3	L/B= 4	L/B= 5
rectangle	1.020	1.415	1.513	1.589	1.833
circle	0.996	1.464	1.748	1.993	2.280
% variation	2.339	-3.487	-15.507	-25.419	-24.364

6.3.1 Semi-infinite layer

Table 6.1 shows the maximum settlement influence factors obtained for a semi-infinite layer and the percentage of variation comparing the maximum settlement influence factors obtained from both rectangular footing and equivalent area of circular footing. From the table we can infer that the percentage of variation is within 5% for L/B less than or equal to 2 while when the L/B value exceeds 2, then the percentage of variation increases and converting the rectangular footing into an equivalent circular footing over estimates the settlement obtained. Since the model is semi-infinite the thickness of the soil layer does not influence the settlement values. The comparison is done for a footing with 150 kPa of pressure, $E= 20\text{MPa}$ and $\nu=0.2$. Figure 6.1 shows the stress contours for rectangle of dimensions $L/B=5$ and equivalent area of circular footing for $E=20 \text{ MPa}$ and $\nu=0.2$ for a semi- infinite layer. From Figure 6.1, we can see that, 10% of q is attained at a depth of 5.5 times H/B in case of circular footing while for a rectangular footing it is 4.75 times H/B . However the distribution of contours is different in x direction though they are almost constant in the z direction. The extent of stress distribution is very wide in case of rectangular footing. The contour in the x direction extends to 2.75 x/B while in the rectangular footing of $L/B=5$, the contour extends to 3.75 times x/B .

Table 6.2: Maximum settlement values and the percentage of variation between rectangular and equivalent circular footing for a semi- infinite layer

Maximum settlement values in m and variation in %										
Shape	L/B= 1		L/B= 2		L/B= 3		L/B= 4		L/B= 5	
	$\frac{H}{B}=1$	$\frac{H}{B}=4$	$\frac{H}{B}=1$	$\frac{H}{B}=4$	$\frac{H}{B}=1$	$\frac{H}{B}=4$	$\frac{H}{B}=1$	$\frac{H}{B}=4$	$\frac{H}{B}=1$	$\frac{H}{B}=4$
rectangle	0.63	0.93	0.73	1.23	0.61	1.23	0.59	0.00	0.74	0.00
circle	0.61	0.92	0.83	1.30	0.46	1.03	0.92	0.00	0.96	0.00
Variation	3.16	1.36	-	-	25.2	16.5	-	-	-	-
			13.90	5.27	1	5	57.4	29.05	28.91	34.43

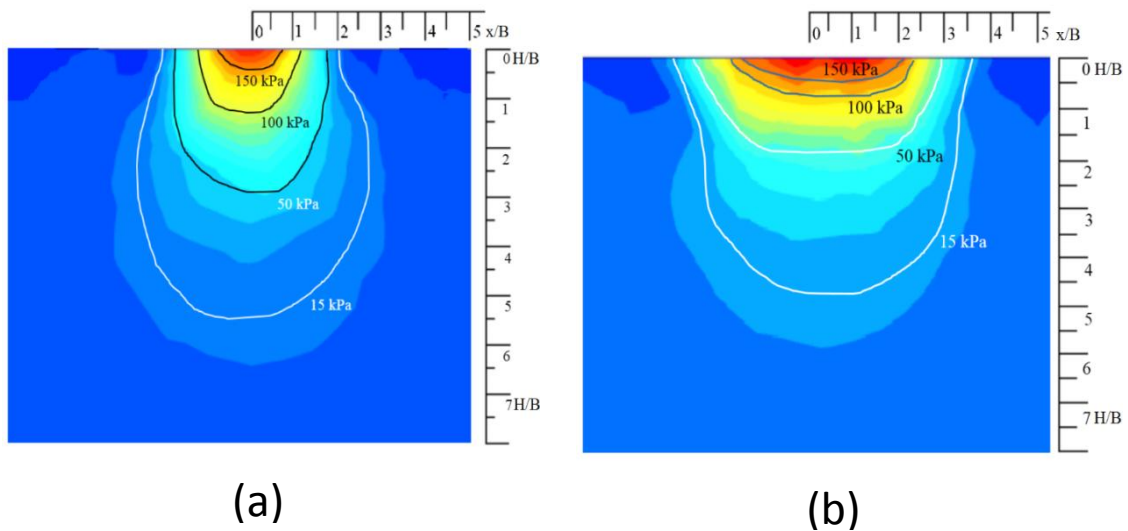

6.3.2 Finite layer

From table 6.2, we can see that the percentage of error is more when H/B is 1 when compared to $H/B=4$. We can also see that the percentage of variation is not similar for finite layers when compared to the semi-infinite layer, where the percentage of error is acceptable when L/B ratio is less than or equal to 2. When $H/B=1$ and $L/B=2$, the percentage of error exceeds 5% and therefore will not yield acceptable results. For rectangular footing the stress distribution is not uniform in both the x and y directions. The extent of stress around the footing also varies. This is consistent with the fact that the pressure bulb varies for different breadth and shape of the footing.

On comparing the settlement due to a footing with $L/B=1$ for semi-infinite layer, $H/B=1$ and $H/B=4$, we can see that the settlement increases as the thickness of the top layer increases, as the rigidity provided by the rigid strata at the bottom is replaced by the soil of lesser modulus of rigidity. However this is not the case with a circular footing. In circular footing, the settlement obtained for $H/B=4$ and semi-infinite is almost the same, as the pressure bulb formed doesn't extend more than $H/B=4$.

Figure 6.1: Stress distribution contours for $L/B=5$ on a semi- infinite layer with (a) equivalent circular footing and (b) rectangular footing in x direction for $q=150$ kPa, $E=20$ MPa and $\nu=0.2$

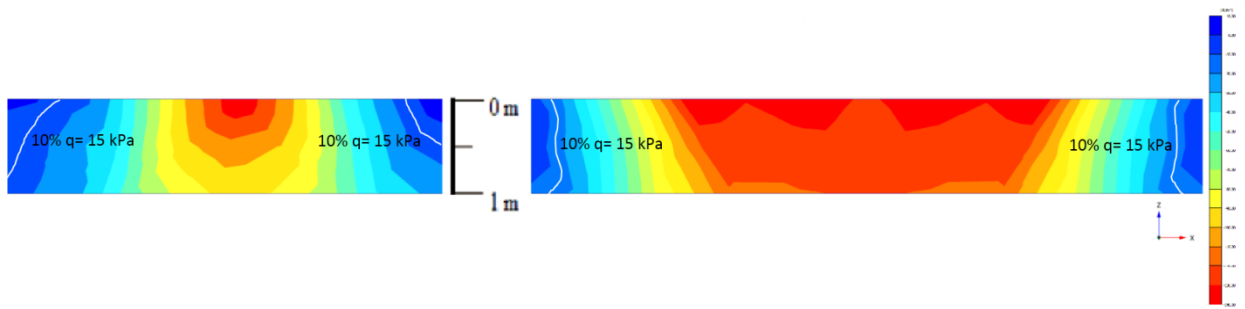

Figure 6.2: Stress distribution contours for $L/B=5$ on finite layer for $H/B=1$ with (a) equivalent circular footing and (b) rectangular footing in x direction for $q=150$ kPa, $E=20$ MPa and $\nu=0.2$

Figures 6.2 and 6.3 shows the stress contours for rectangle of dimensions $L/B=5$ and equivalent area of circular footing for $E=20$ MPa and $\nu=0.2$ for finite layer with $H/B=1$ and 4. Comparing the figures we can see that the stress distribution is wide spread in $H/B=1$ as the layer thickness is very small.

The conversion of square footing into an equivalent area of circular footing does not yield much variation in result. This might be because both the footings are axis symmetric, and therefore the area of influence around the footing and pressure bulb almost remains constant. From Figure 6.4, we can see that the conversion of square footing to an equivalent area transfers from the white region in the image to the black areas when converted to circular footing. The change in the area of load applied is minimum and therefore the conversion can be carried out in case of square footings with minimum error. From table 6.3, we can see that the percentage of variation between the maximum settlement influence factors for circular and square footing is acceptable.

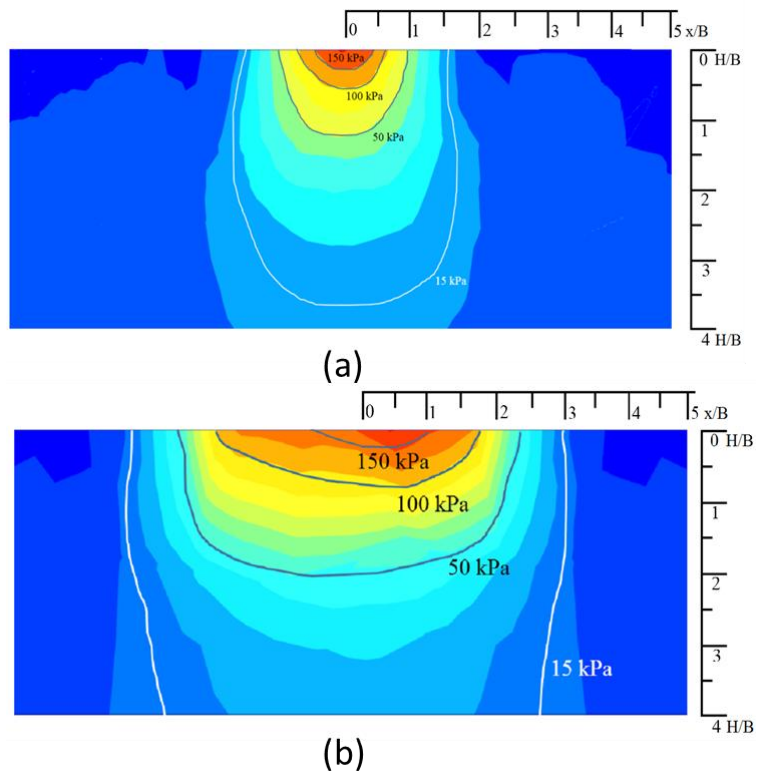

Figure 6.3: Stress distribution contours for $L/B=5$ on finite layer for $H/B=4$ with (a) equivalent circular footing and (b) rectangular footing in x direction for $q=150$ kPa, $E=20$ MPa and $\nu=0.2$

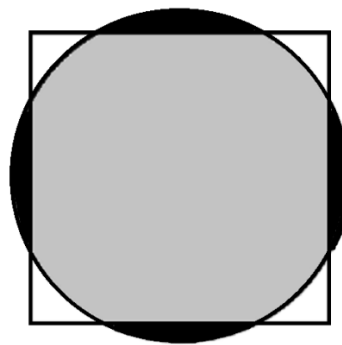

Figure 6.4: Square footing converted to equivalent area of circular footing

Table 6.3: Maximum settlement values and the percentage of variation between rectangular and equivalent circular footing

Rectangul	Equivale	Semi Infinite	Finite Layer
-----------	----------	---------------	--------------

Square Footing Dimension m^2	Equivalent Area for Square and Circle	Layer		H/B=1		H/B=4	
		$I_{\rho, max}$	% variation	$I_{\rho, max}$	% variation	$I_{\rho, max}$	% variation
2x1	square	1.46	-0.274	0.993	-5.168	1.373	-1.553
	circle	1.46 4		1.045		1.395	
5x1	square	2.27 1	-0.411	0.002	-5.979	0.002	-1.951
	circle	2.28		0.002		0.002	

6.4 Comparison between Rectangular and Circular Footing

Conversion of a footing into equivalent area of footing and analyzing is applicable only if

- 1) The soil is a semi-infinite strata and
- 2) the footing has L/B ratio less than or equal to 2

It is also to be noted that conversion of circular footing to equivalent area of square footing or vice versa always gives results within acceptable errors. When the top layer thickness is less than the influence of the pressure bulb of either footing for a footing (or equivalent area of footing) with one finite layer of soil, then the conversion factor will not generally work.

Chapter 7

Rigidity of the Footing

7.1 Introduction

Foundations in general are neither perfectly rigid nor flexible. In cases of single reinforced isolated footings, the footings behave more like a rigid footing while in the case of mat foundations, they behave more like a flexible footing. Analysis of both extreme cases will help understand the general behaviour. Settlements under the footing will be uniform in the case of rigid footing while the stress will vary with the contact stress distribution. The contact stress differs for sand and saturated clay layers. Sands have higher contact stress towards the centre and peaks at the centre. For saturated clays the stiffness below rigid footing remains almost constant and therefore generally assumed uniform. However, the stiffness of the footing can be explained in terms of relative stiffness (K_r) as defined by Meyerhof(1953) in equation 14. The equation explains if the footing is to be designed as rigid or flexible taking into account $E'I_F$ is the flexural stiffness of the foundation, $E'I_b$ is the flexural stiffness of individual framed member, t_w is the thickness of the walls, h_w is the height of the walls and $\frac{E't_w h_w^3}{12}$ is the flexural stiffness of shear wall and

$$E'I_B = E'I_F + \sum E'I_B + \frac{E't_w h_w^3}{12}$$

$$K_r = \frac{E'I_B}{E_s B^3} \dots\dots$$

(14)

Whitman and Richart proposed settlement influence factor, β_z , for rigid footings on a semi-infinite homogeneous layer of soil for rectangular footings of different dimensions to determine the settlement values. The factor, β_z , depends on the aspect

ratio, L/B of the footing. Sovinc proposed the solutions for a rigid footing on a finite layer of soil by proposing a settlement factor β , where β depends on the aspect ratio, L/B , and the normalised thickness of the layer with respect to the length of the footing, H/L . The US Navy Soil and Foundation design manual has also proposed the settlement influence factor for both semi-infinite and finite layer of soil. They have given the settlement factors for both rigid and flexible footings at the centre and the corners for rectangular footing for various dimensions. In the case of finite layer of soil, the values proposed are for Poisson ratio of either 0.33 or 0.5. The above descriptions are for soils with semi-infinite layers of homogeneous soil or single, finite layer of soil underlain by a rigid base. However in reality, the soil does not always occur homogeneous or for a finite layer thickness. This chapter proposes the settlement factors for a finite layer of soil and two layered system of soil underlain by a rigid base.

7.2 Problem Definition

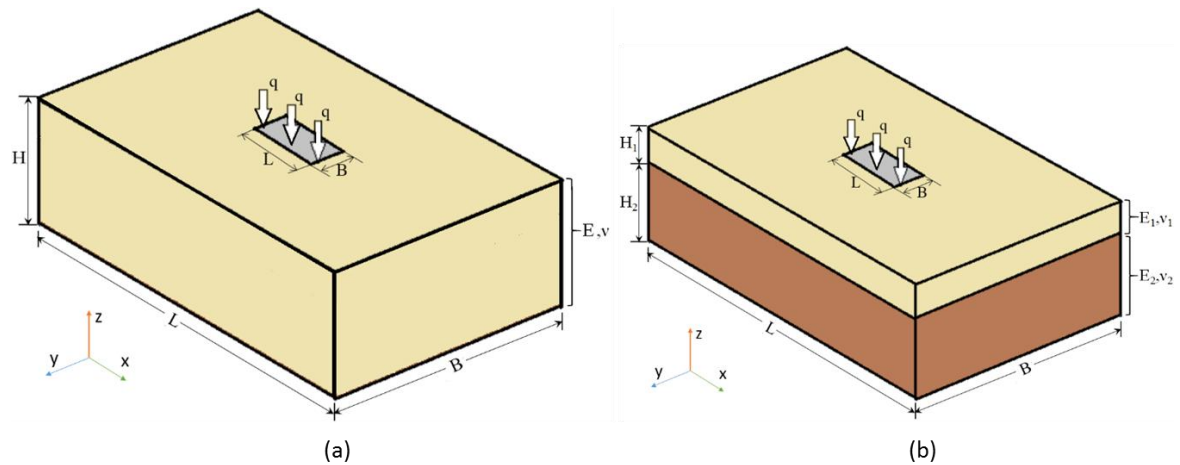

Fig. 1 Model of soil for a) finite layer of soil and b) two layer soil system underlain by a rigid base

A prescribed displacement of rectangular area is induced by applying a load 'q' on a plate of dimensions L and B, where L is the length of the footing and B is the width

of the footing. The settlement of two-layered system due to rigid rectangular loading can be represented as shown in equation 1

$$\rho = \frac{qB(1-\nu^2)I_{p,r}}{E_2}$$

(Eq. 1)

where, ρ is the settlement of rigid rectangular footing under an applied load of intensity equal to q , B is the width of the footing, ν is the Poisson ratio of the soil and E_2 is the deformation moduli of the bottom layer and $I_{p,r}$ is the settlement influence factor can be obtained from the graphs presented in the paper for rigid footing.

7.2.1 Finite Layer of Soil

The thickness of the soil is defined as H with the elastic deformation properties; the deformation modulus and the Poisson ratio are defined as E and ν , respectively.

7.2.2 Two Layer Soil System

The thicknesses of the top and bottom layers are H_1 and H_2 respectively in a two layer soil system. The elastic deformation properties, deformation modulus and the Poisson ratio are E_1, ν_1 and E_2, ν_2 respectively. The settlement influence factor for rigid footing is obtained. They are compared with the settlement influence factors obtained for flexible footing.

7.3 Finite Element Model

Finite Element analysis (FEA) is used to analyse the settlement influence factor, $I_{p,r}$, using PLAXIS 3D version 2013. Linear elastic model was considered for the soil layers. 10 noded triangular elements were used. Convergence study was done for both meshing and boundary distance. Fine refinement was chosen with local volume refinement of 0.125 times the element size. The boundary distance was chosen as 61

times the width of the footing. In Figure 78, the model depicted has 298872 soil elements with average element size as 0.3865 m with maximum element size approximately 3.175m and minimum size values up to 0.101m. Boundary condition at the top of the model is free in all directions while it is fixed in all directions in the bottom. The boundary conditions parallel to the length of the footing are fixed in the y direction i.e. $u_y=0$ and the boundary condition parallel to the breadth are fixed in the x direction i.e. $u_x=0$. Automated boundary condition in PLAXIS 3D is adopted, which satisfies our problem requirement.

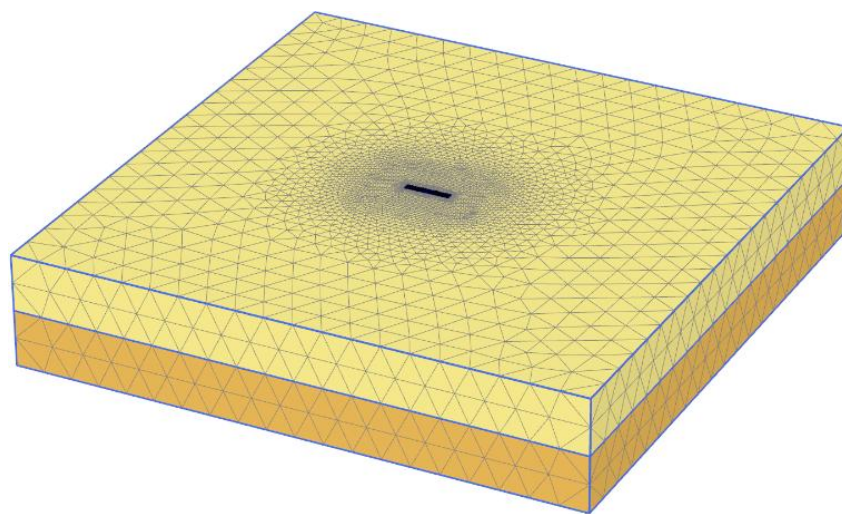

Figure 78 Finite Element Model for $L/B=5$, $H_1/B=6$, $H_2/B=6$, $E_1/E_2=100$ as in PLAXIS 3D v 2013 for a two layer soil system

7.4 Validation

Prior to performing study on the finite layer and two layer, validation was performed for semi-infinite layer using the results published by the US Navy manual. From figure 3, it can be concluded that the values obtained through Finite Element Analysis (FEA) correlates with the values stated in the US Navy manual. The correlation with respect to Whitman and Richart is satisfactory except for the value corresponding to $L/B=1$.

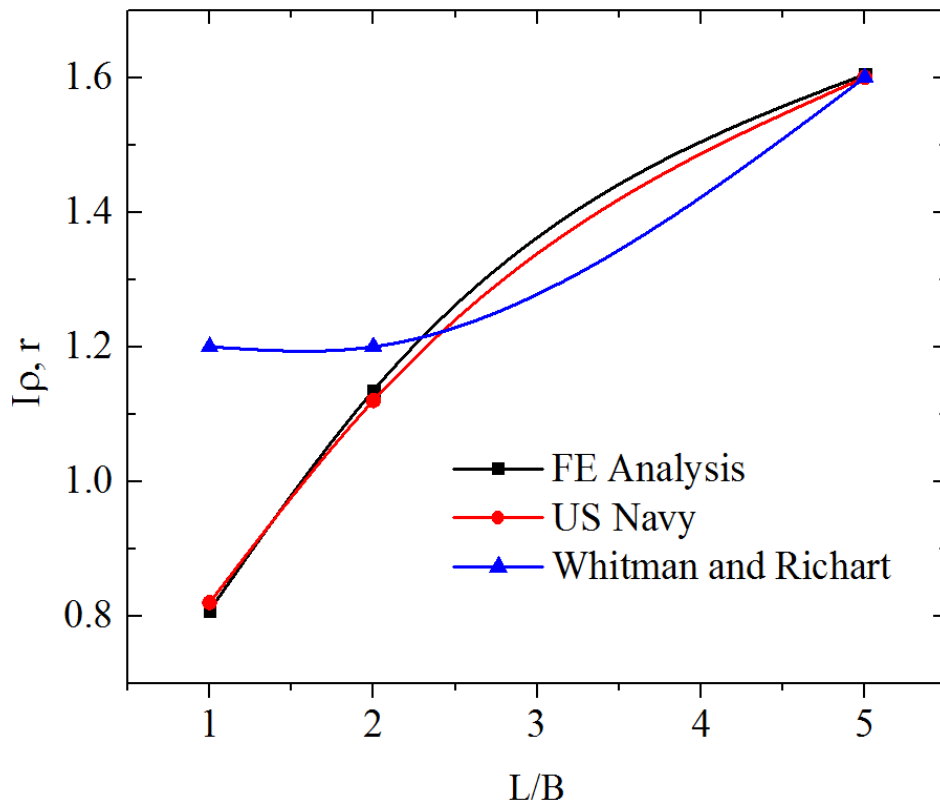

Figure 3 Validation for a Semi-Infinite Layer of Soil

7.5 Results and Discussion

Settlement influence factors for rigid footing has been proposed for infinite layer of soil, finite layer of soil with a rigid layer at the bottom, and two layer soil system underlain by a rigid layer. Settlement influence factor for rigid footing, $I_{p,r}$, has been proposed in the form of charts by varying $L/B=1,2$ and 5 , $E_1/E_2=0.01, 0.1, 0.5, 2, 10$ and 100 , $H_1/B=0.5,1, 2, 4$ and 6 , $H_2/B=1,2, 4$ and 6 , and $H/B= 1, 2, 4$ and 6 . Figure 2 shows the settlement influence factors $I_{p,r}$, for a finite layer of soil.

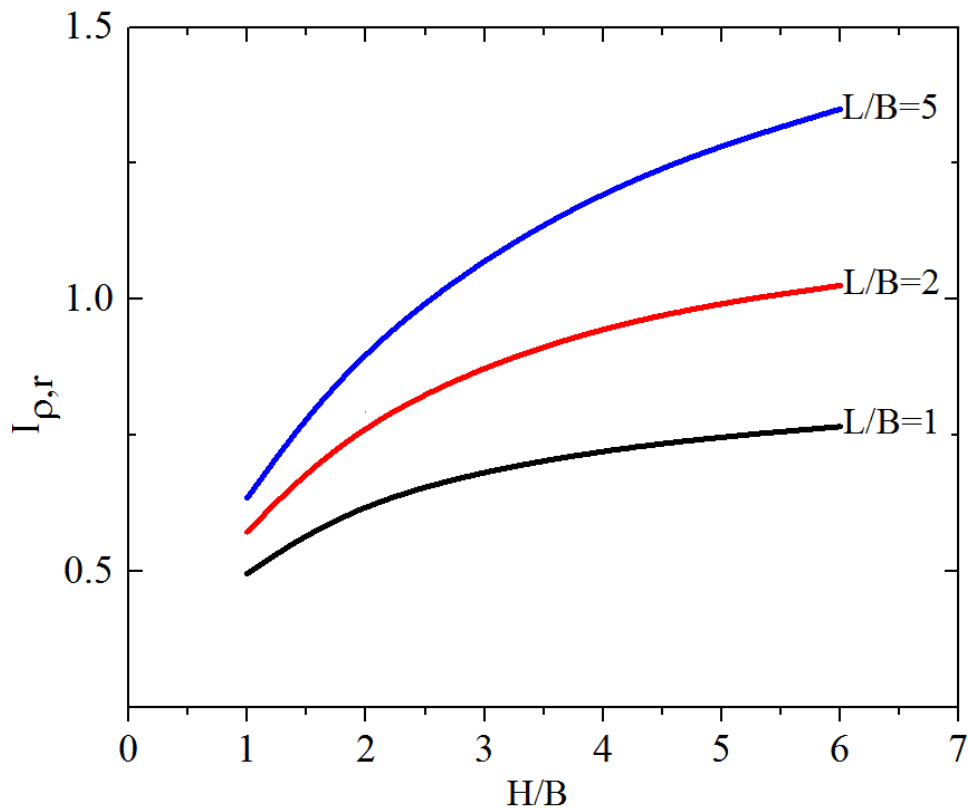

Figure 2 Settlement Influence Factor for Rigid Footings with Finite Layer of Soil

7.5.1 Finite Layer of Soil

The thickness of the top layer influences the settlement influence factor to a certain extent. The influence is generally valid if the thickness of the footing is very close to the influence depth of the particular footing, which in turn is dependent on the aspect ratio of the footing.

7.5.1.1 Influence of L/B ratio

From figure 2, it can be understood that the influence factor increases as the L/B ratio increases for a finite layer of soil underlain by a rigid base.

7.5.1.2 Influence of H/B

As H/B increases, the influence factor increases. However the rate of increase is dependent on the depth of influence for a particular aspect ratio of the footing. For

example, in figure 2, for $L/B=1$, the rate of increase becomes minimal at the point of $H/B=2.5$, while for $L/B=2$, it reaches at around $H/B=4$.

7.5.2 Two Layer Soil System

7.5.2.1 Influence of L/B

As with the case of finite layer, in two layer soil system the settlement influence factor increases as the L/B value increases. For example, for $L/B=1$ and 2, for $H_1/B=2$ and $H_2/B=2$ and $E_1/E_2=0.01$, it can be observed that the value varies by 16% while between $L/B=2$ and 5 for the same parameters, the variation is 10.6%

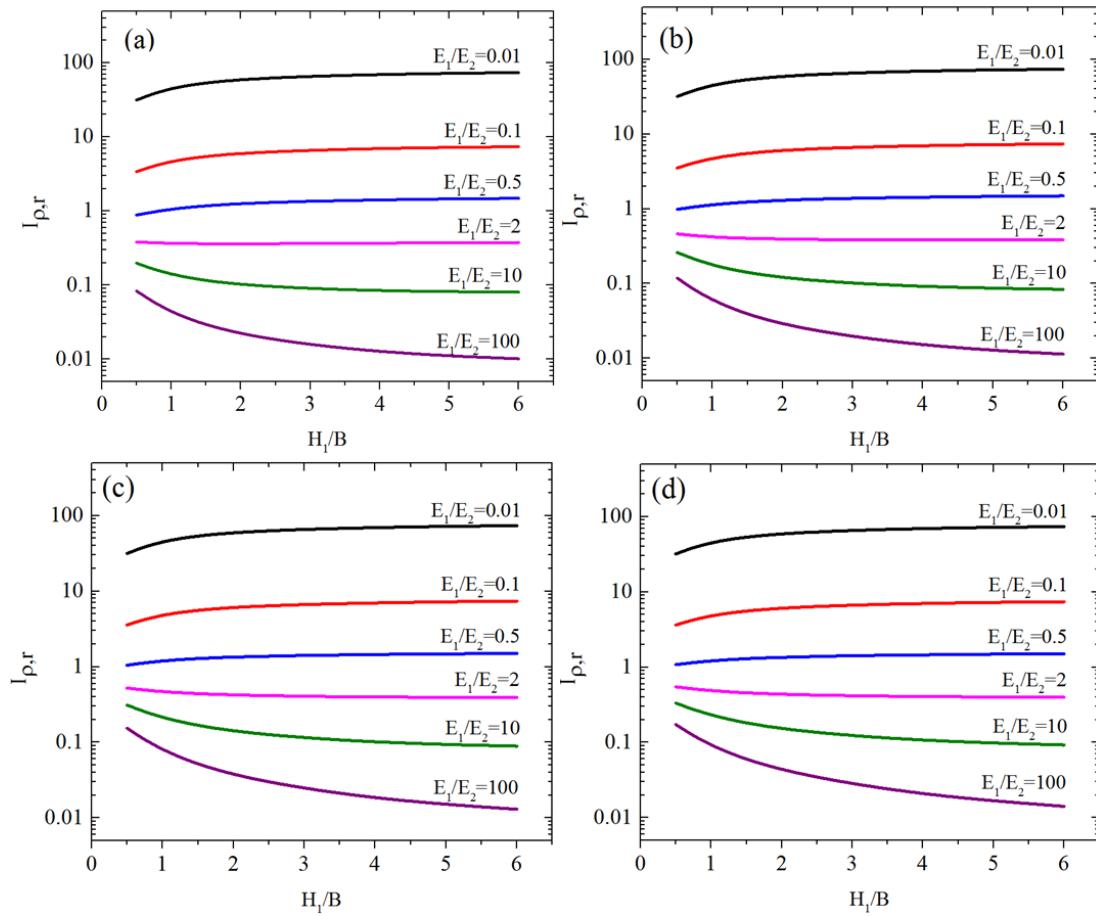

Figure 5 Settlement influence factor for rigid footing for $L/B=1$ for (a) $H_2/B=1$, (b) $H_2/B=2$, (c) $H_2/B=4$ and (d) $H_2/B=6$ for various H_1/B and E_1/E_2 values

7.5.2.2 Influence of E_1/E_2

The ratio E_1/E_2 refers to the relative stiffness of the soil of the top to the bottom layer. From the figures 5 to 7, as E_1/E_2 increases then the settlement influence factor decreases. From Figure 5(a), for $L/B=1$, $H_1/B=2$, $H_2/B=1$ for $E_1/E_2=0.1$ and $E_1/E_2=0.5$, it can be seen that the settlement influence factor decreases at the moduli ratio increases by 378% and between $E_1/E_2=0.01$ and $E_1/E_2=0.1$, it is 897%. The top layer becomes stiffer when compared to the bottom layer as E_1/E_2 increases. Therefore the settlement decreases as the top layer becomes stiffer.

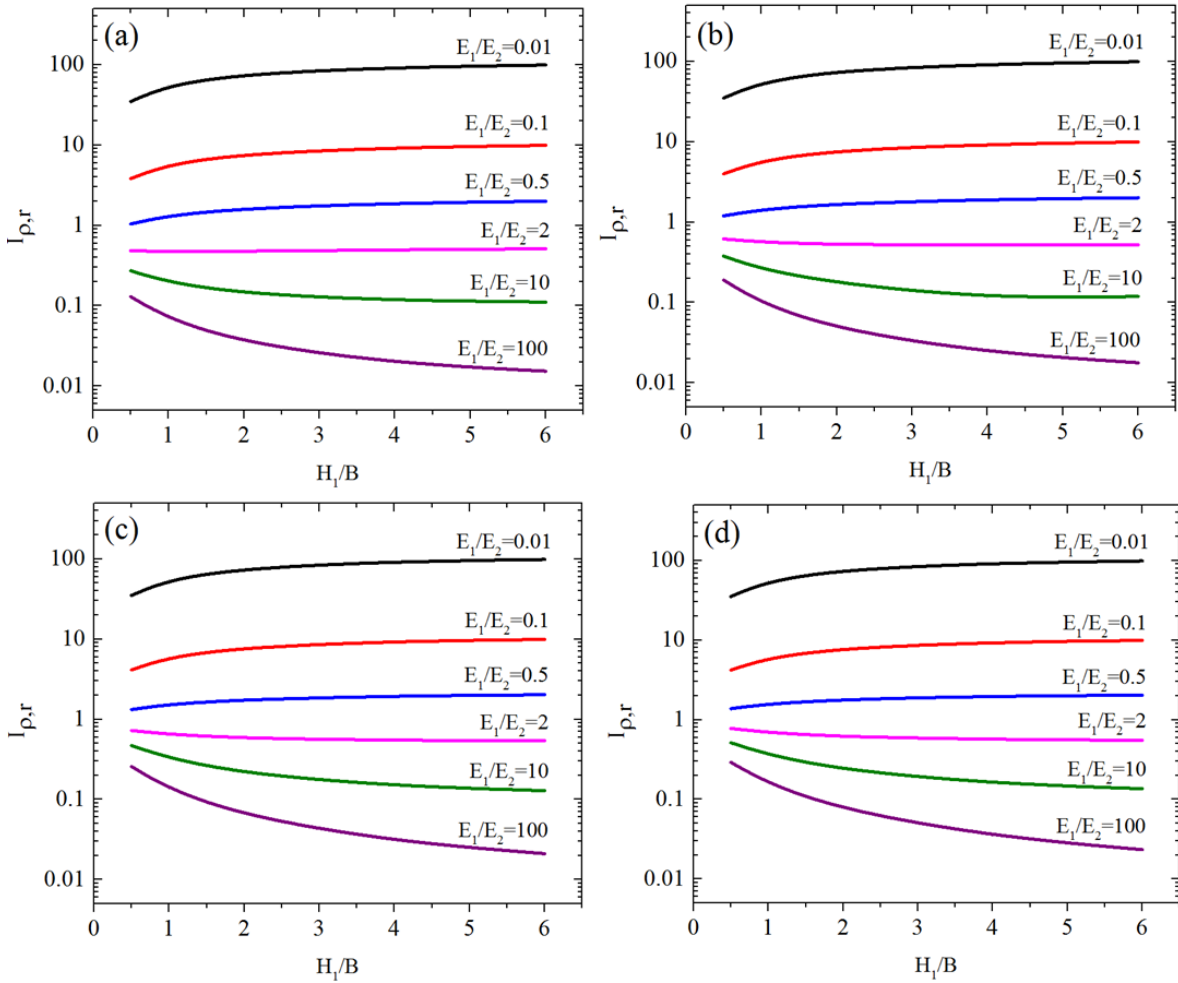

Fig. 6 Settlement influence factor for rigid footing for $L/B=2$ for (a) $H_2/B=1$, (b) $H_2/B=2$, (c) $H_2/B=4$ and (d) $H_2/B=6$ for various H_1/B and E_1/E_2 values

7.5.2.3 Influence of H_1/B

From figure 5, as H_1/B value increases the settlement increases for $E_1/E_2 < 1$, while it decreases for $E_1/E_2 > 1$. For example, in the same figure, for $L/B=1$, $E_1/E_2=0.01$, $H_2/B=1$, as H_1/B varies from 0.5 to 1, the settlement factor increases by 51% while for $E_1/E_2=10$, the value decreases by 31%. As the top layer is stiffer for $E_1/E_2 > 1$, as the thickness of the top layer increases, more resistance is offered by the top layer due to its stiffness. Similarly, for $E_1/E_2 < 1$, the top layer becomes less stiff, and therefore as the thickness increases, the resistance offered by the top layer is less.

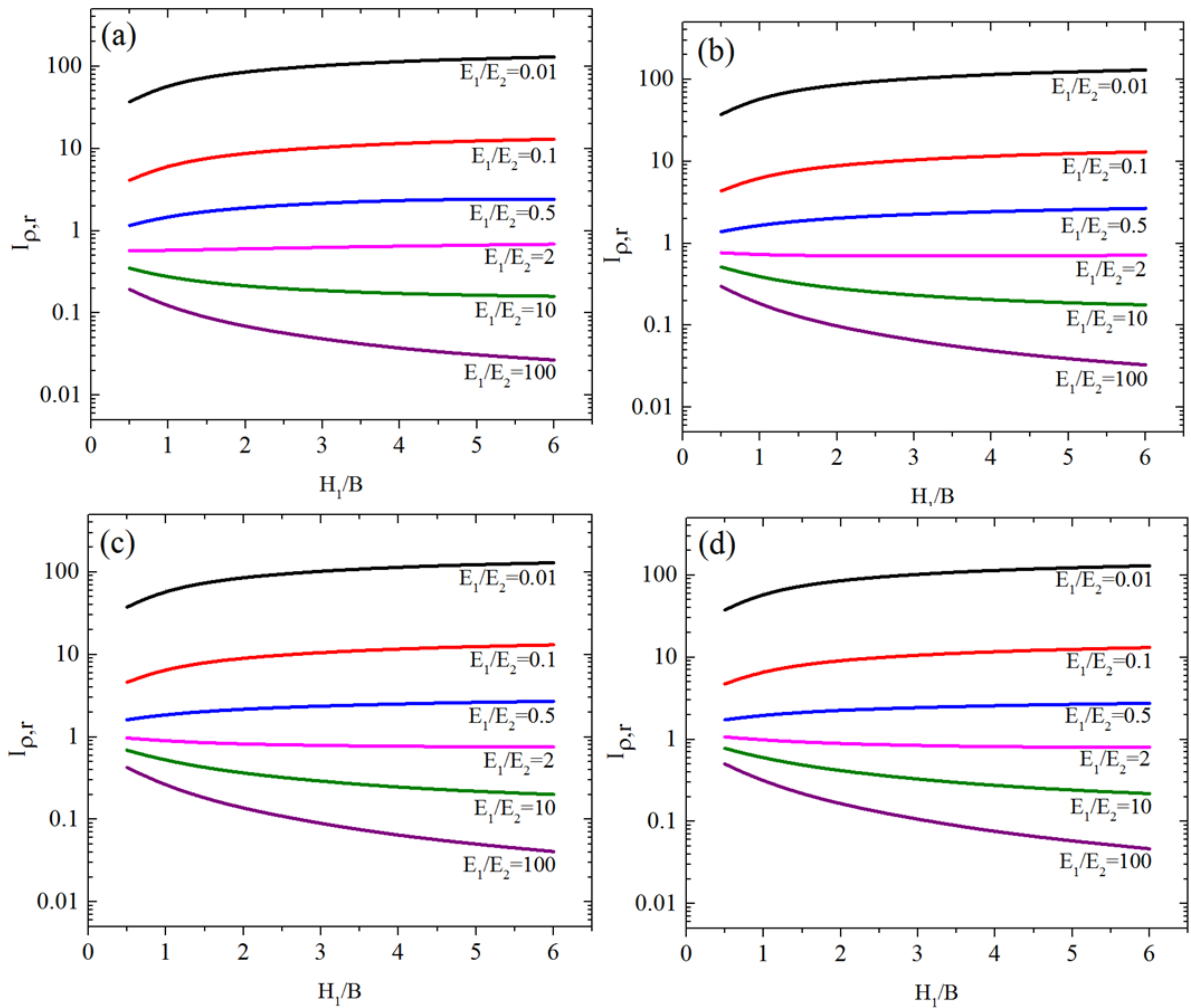

Figure 7 Settlement influence factor for rigid footing for $L/B=5$ for (a) $H_2/B=1$, (b) $H_2/B=2$, (c) $H_2/B=4$ and (d) $H_2/B=6$ for various H_1/B and E_1/E_2 values

From the graphs, it is inferred that the rate of change decreases as H_1/B value increases. For example, from figure 5, for $L/B=1$, $E_1/E_2=0.1$, $H_2/B=1$, the variation between $H_1/B=0.5$ and $H_1/B=1$ is 51% while between $H_1/B=4$ and 6, the variation is reduced to 5%. The reduction in the rate of change, either increase or decrease, is due to the fact that, as the top layer thickness increases, the strata behaves more like a one finite layer of soil and the influence of the bottom layer is eliminated, more so in the case of top layer having more stiffness.

7.5.2.4 Influence of H_2/B

From figure 5 (a) and (b) as the H_2/B ratio increases, the settlement influence factor also increases. For example, as H_2/B ratio increases from 1 to 2 for $L/B=1$, $E_1/E_2=0.5$, $H_1/B=0.5$, the settlement influence factor increases by 1%. As the H_1/B value increases, the influence of H_2/B decreases. The influence of the bottom layer decreases as the top layer stiffness increases: the factor more prominent when the top layer is stiffer.

7.6 Comparison

Figure 8 shows the comparison between the data obtained for rigid and flexible footing at the centre of the footing. As expected the settlement of the flexible footing is a little higher when compared to the settlement of the rigid footing at the centre. In flexible footings, the settlement at the centre is the maximum while it tapers at the extremes while in rigid, an average settlement is expected throughout the footing.

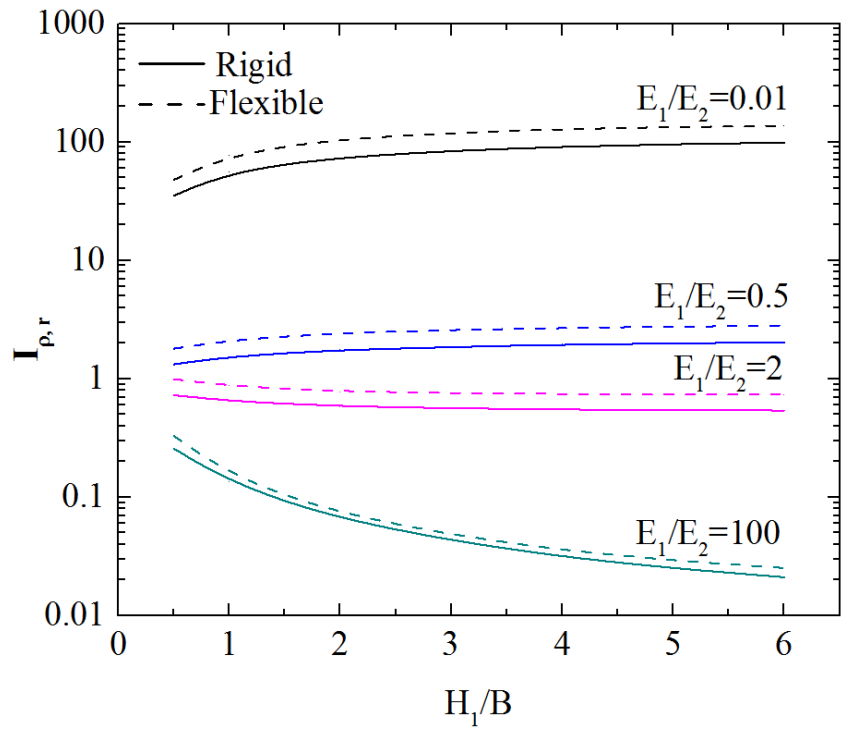

Figure 8 Comparison of settlement factors between rigid and flexible footing for $L/B=2$, $H_2/B=4$ for various H_1/B values

Chapter 8

Depth of Embedment

8.1 Introduction

Footings, in general, are founded inside the soil with an exception for machinery foundations, which are at the surface. The analysis methods proposed therefore should take into consideration the depth of embedment of the footing. Various analytical solutions proposed by researchers took into consideration the depth as explained in the literature review. In general, the soil above the footing was considered as surcharge and the stress distribution was considered according to depth at which the footing is embedded. However, when considering the settlement of the footing on a two layered soil system underlain by a rigid base, converting the soil above the footing to a surcharge may not be possible due to variation in the soil properties. The distribution of the stress below the footing cannot be considered directly understandably due to variation of properties below the footing. The thickness of the layers below the footing also plays a significant role in the distribution of the stress below the footing.

Researchers like Groth and Chapman(1969), Fox(1948) and Burland(1970) have done a serious analysis considering the settlement when the footing is embedded at a particular footing. However all the analysis carried out by the researchers are for semi-infinite layer of soils.

8.2 Problem Definition

A uniform rectangular load of intensity 'q' acts on a two-layered soil system underlain by a firm stratum. The rectangular area of load is defined by the dimensions L and B at a depth D normalised with the breadth of the footing, B. The

thicknesses of the top and bottom layers are H_1 and H_2 , respectively as shown in figure 8.1. The objective of the study is to analyse the maximum settlement influence factors at the centre of the footing embedded at a depth. Influence factors are introduced to include the effects of the depth of embedment influencing the settlement. The influences of the factors are studied independent of the other influencing factors. In addition, the settlement profiles in both x and y directions are also presented. The vertical variation of the settlement is also presented to understand the effect of displacement profile for a two layered soil system.

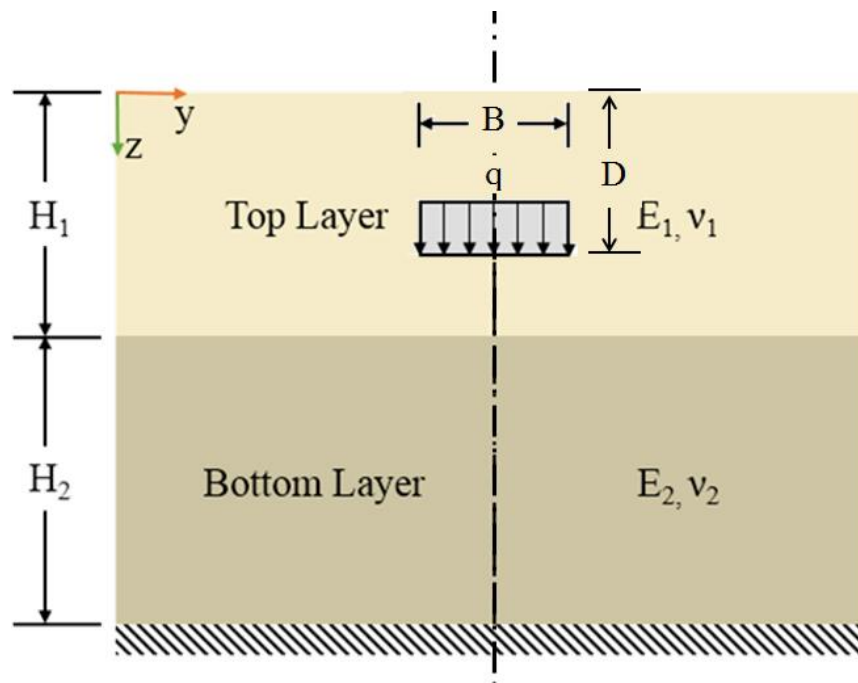

Figure 8.1 Schematic Diagram for a Rectangular Footing to analyse the Depth of Embedment

8.3 Validation

Trow and Bradstock (1972) studied the settlement of caisson and raft foundations for Leaside Towers in Metro Toronto, Ontario, Canada. It is a 43-storeyed structure consisting of two towers, one tower is supported on a caisson foundation and the other on a raft foundation. In this study, the settlement of raft foundation is

considered to validate the finite element model. Raft consisted of three parts connected to each other by construction joints and was placed at a depth of 5m from the ground surface. The raft footing was founded on 4m-thick medium sand underlying 13m-thick clayey silt till and 17m-thick silt and silt till deposit below the level of the footing as defined in Chapter 5 validation. The maximum settlement of the raft footing was interpolated from the measured settlements values and was obtained as 39.3 mm.

Considering the dimensions of the raft foundation, we have obtained the ratios as $L/B = 2.72$, $H_1/B=0.5$, $H_2/B=0.54$ and $E_1/E_2=0.502$. The value of Poisson's ratio of soil layers was assumed to be equal to 0.25 (Enkhtur et al. 2013). The maximum settlement equal to 38.6 mm was obtained from the finite element model considered in this study, a difference of 2% from the measured value. This could be due to the fact that the raft was assumed to be a single continuous raft while in reality it consisted of three parts connected by construction joints.

The settlement of layered soil system from the finite element model was found to compare very well with the measured settlement of footings reported in the case study. The same finite element model was used to further carry out an extensive parametric study. Based on the finite element analysis, the settlement influence factors were deduced and presented for a wide range of geometric and elastic properties of the layered soil system. Results in the form of charts and the effects of various parameters on the maximum settlements and surface settlement profiles for rectangular loading are discussed next.

8.4 Settlement Influence Factors at Depth of Embedment

The settlement influence factors at the depth of embedment were analysed for normalised depth of embedment, D/B of 0.2, 0.5 and 1 and parametric study was carried out as already discussed in Chapter 5. The interdependency of the already defined parameters have been defined in detail in Chapters 5 and 6. Charts representing settlement influence factors dependent on the depth of embedment are

represented from figures 8.2 to 8.10. The values for a footing embedded at a particular depth can be interpolated from the graphs presented. Figures 8.11, 8.13, 8.15 and 8.17 show the settlement profile at the surface of the footing embedded at a depth of 0.2, 0.5 and 1 from the surface of the soil for two thicknesses of the top layer, H_1/B of 1 and 4 and bottom layer thickness of $H_2/B=4$. Figures 8.11, 8.13, 8.15 and 8.17 show the settlement profile at the surface of the footing embedded at a depth of 0.2, 0.5 and 1 from the surface of the soil for two thicknesses of the top layer, H_1/B of 1 and 4 and bottom layer thickness of $H_2/B=4$. Figures 8.12, 8.14, 8.16 and 8.18 show the settlement profile at the depth of embedment of the footing embedded at a depth of 0.2, 0.5 and 1 from the surface of the soil for two thicknesses of the top layer, H_1/B of 1 and 4 and bottom layer thickness of $H_2/B=4$, respectively. The extent of settlement at the surface and the depth of embedment can be studied from the above-mentioned graphs. Comparing graphs from figures 8.11 and 8.12, we can see that the settlement at the depth of embedment is higher when compared to the settlement at the surface.

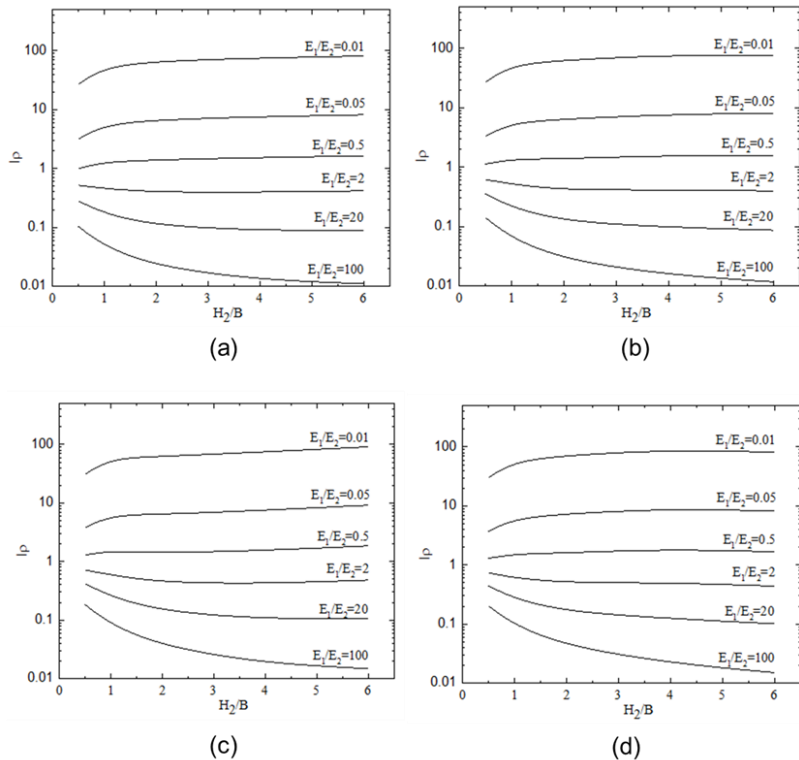

Figure 8.2 Settlement influence factor for $D/B=0.2$ for $L/B=1$ for (a) $H_2/B=1$, (b) $H_2/B=2$ (c) $H_2/B=4$, (d) $H_2/B=6$

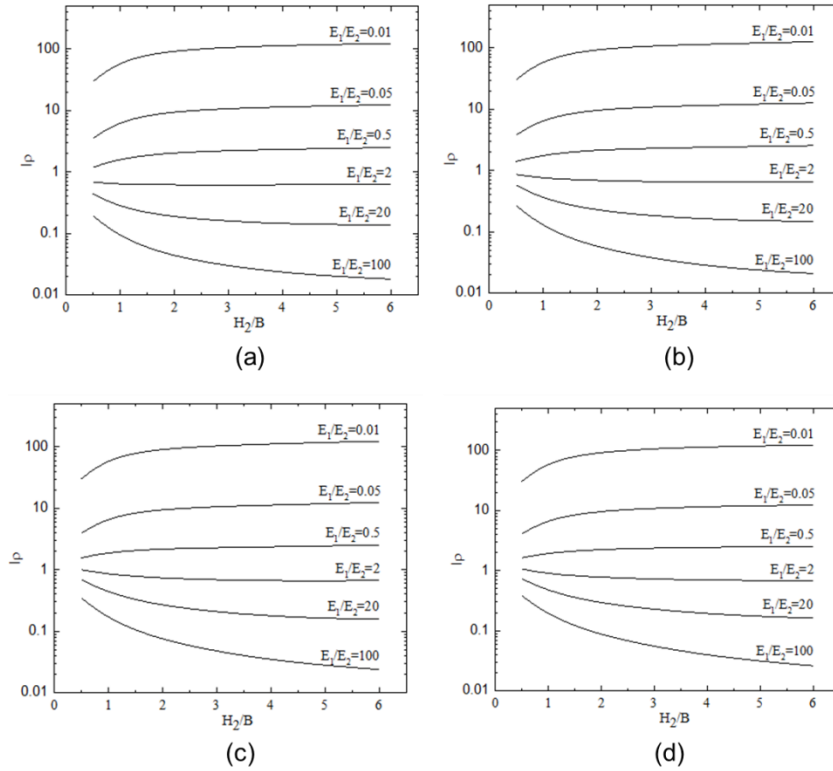

Figure 8.3 Settlement influence factor for $D/B=0.2$ for $L/B=2$ for (a) $H_2/B=1$, (b) $H_2/B=2$ (c) $H_2/B=4$, (d) $H_2/B=6$

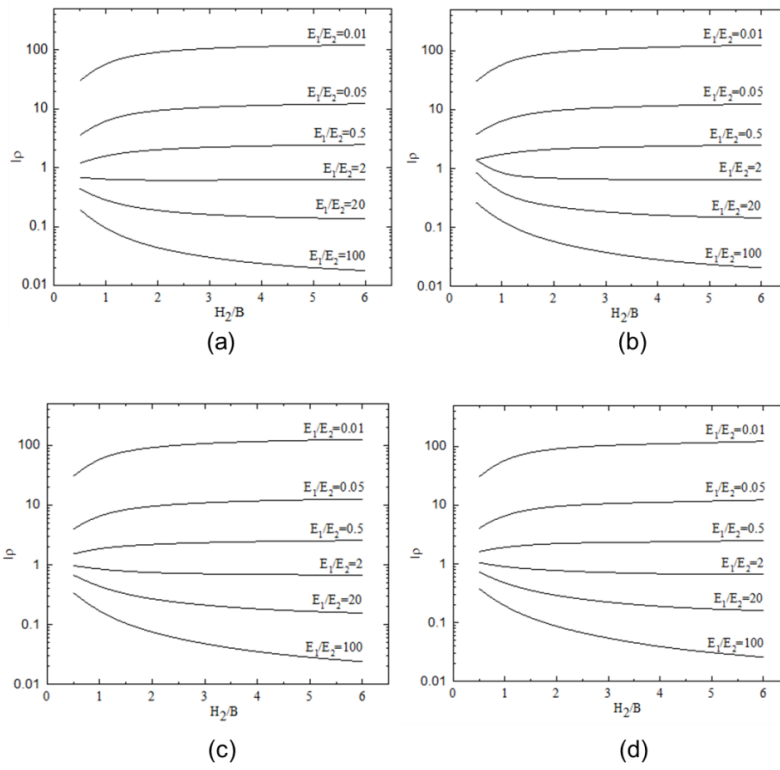

Figure 8.4 Settlement influence factor for $D/B=0.2$ for $L/B=5$ for (a) $H_2/B=1$, (b) $H_2/B=2$ (c) $H_2/B=4$, (d) $H_2/B=6$

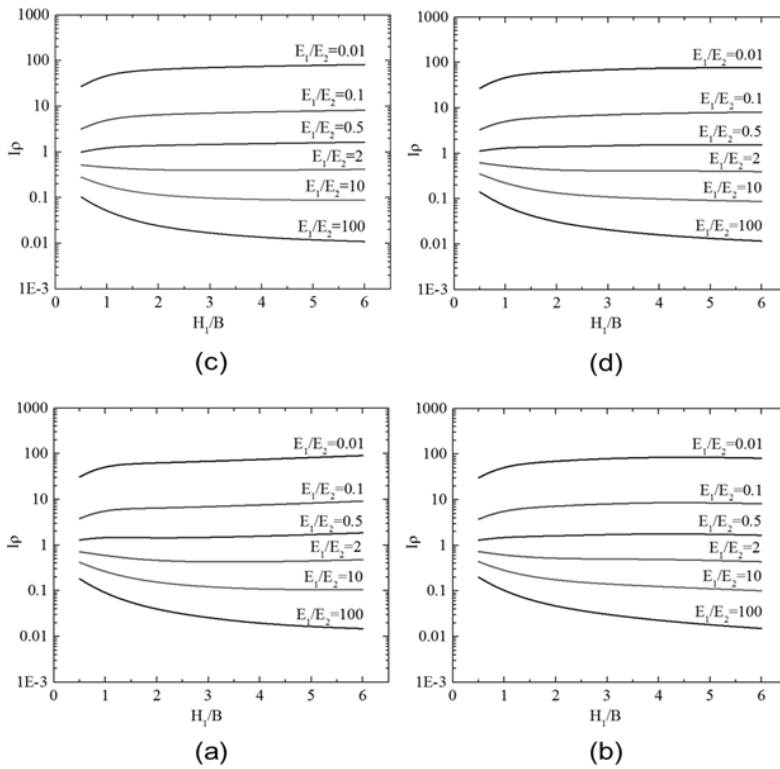

Figure 8.5 Settlement influence factor for $D/B=0.5$ for $L/B=1$ for (a) $H_2/B=1$, (b) $H_2/B=2$ (c) $H_2/B=4$, (d) $H_2/B=6$

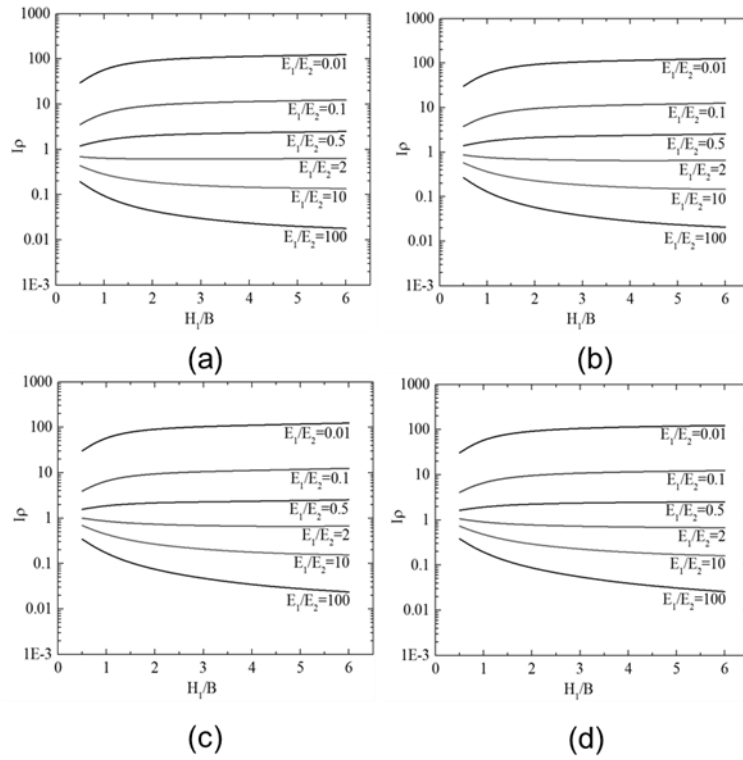

Figure 8.6 Settlement influence factor for $D/B=0.5$ for $L/B=2$ for (a) $H_2/B=1$, (b) $H_2/B=2$ (c) $H_2/B=4$, (d) $H_2/B=6$

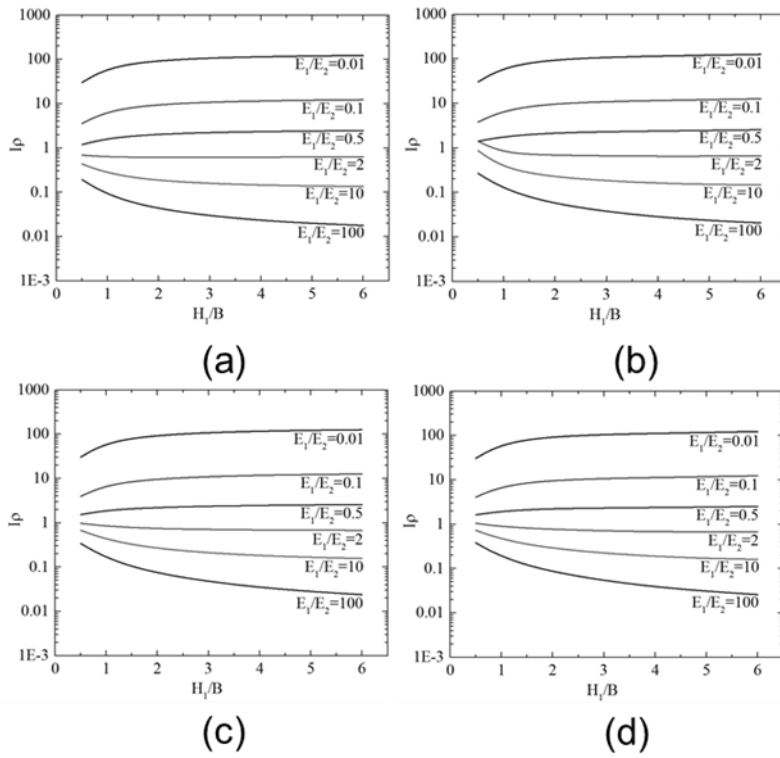

Figure 8.7 Settlement influence factor for $D/B=0.5$ for $L/B=5$ for (a) $H_2/B=1$, (b) $H_2/B=2$ (c) $H_2/B=4$, (d) $H_2/B=6$

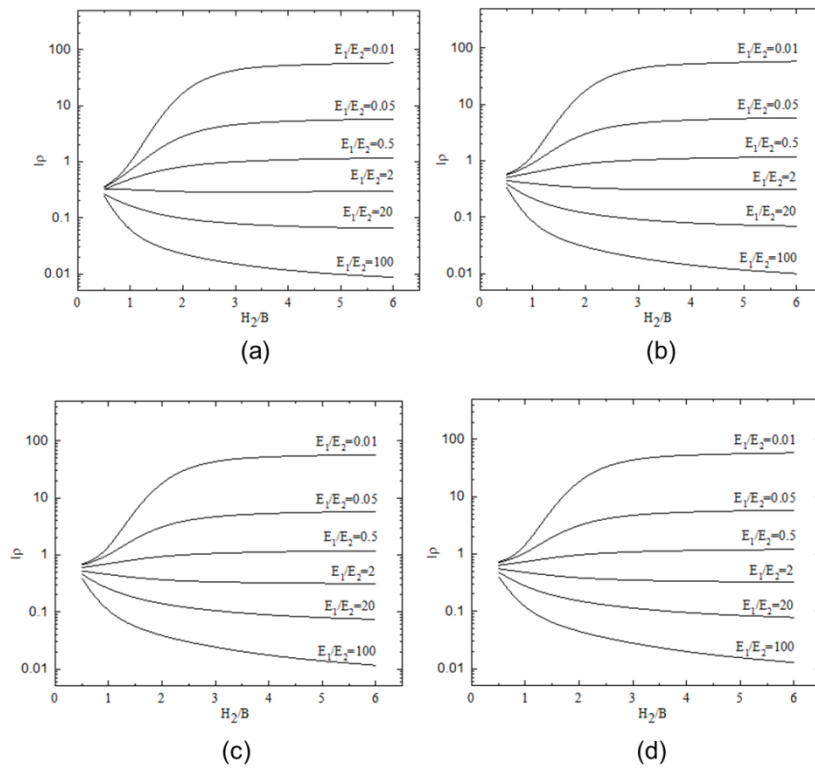

Figure 8.8 Settlement influence factor for $D/B=1$ for $L/B=1$ for (a) $H_2/B=1$, (b) $H_2/B=2$ (c) $H_2/B=4$, (d) $H_2/B=6$

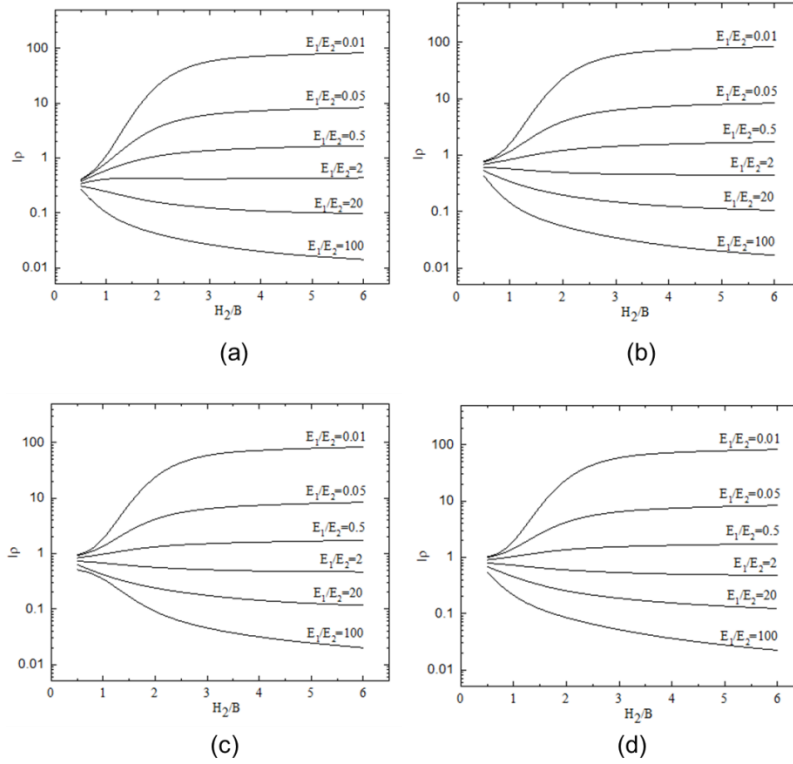

Figure 8.9 Settlement influence factor for $D/B=1$ for $L/B=2$ for (a) $H_2/B=1$, (b) $H_2/B=2$ (c) $H_2/B=4$, (d) $H_2/B=6$

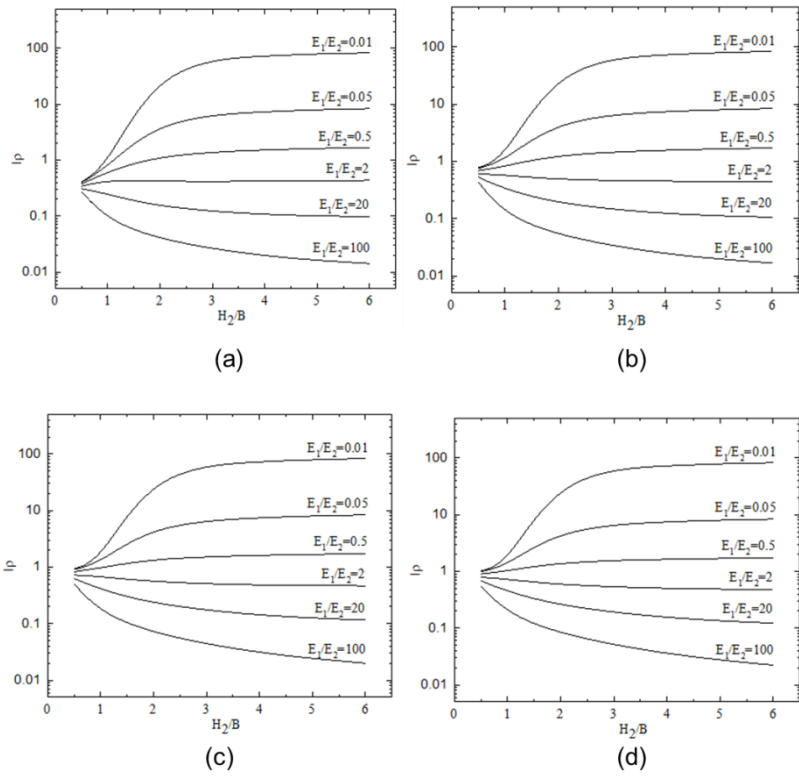

Figure 8.10 Settlement influence factor for $D/B=1$ for $L/B=5$ for (a) $H_2/B=1$, (b) $H_2/B=2$ (c) $H_2/B=4$, (d) $H_2/B=6$

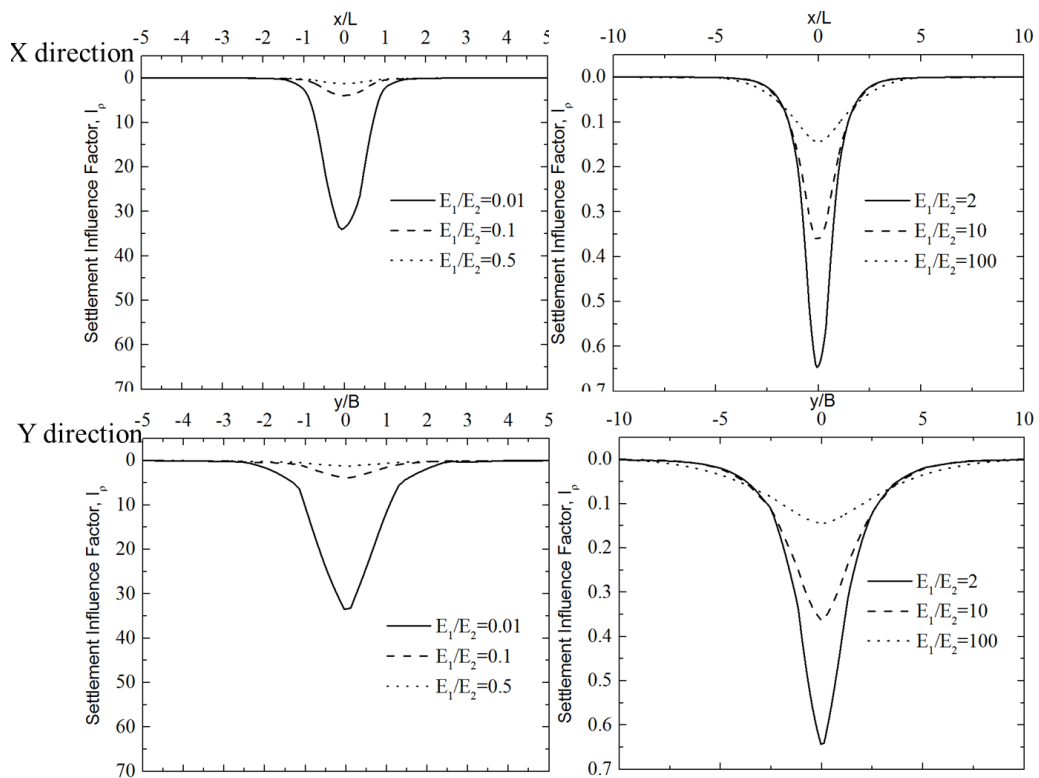

Figure 8.11 Surface Settlement Influence Factor Profile for $D/B=0.5$ for $L/B=2$, $H_1/B=1$ and $H_2/B=4$ in the x and y direction

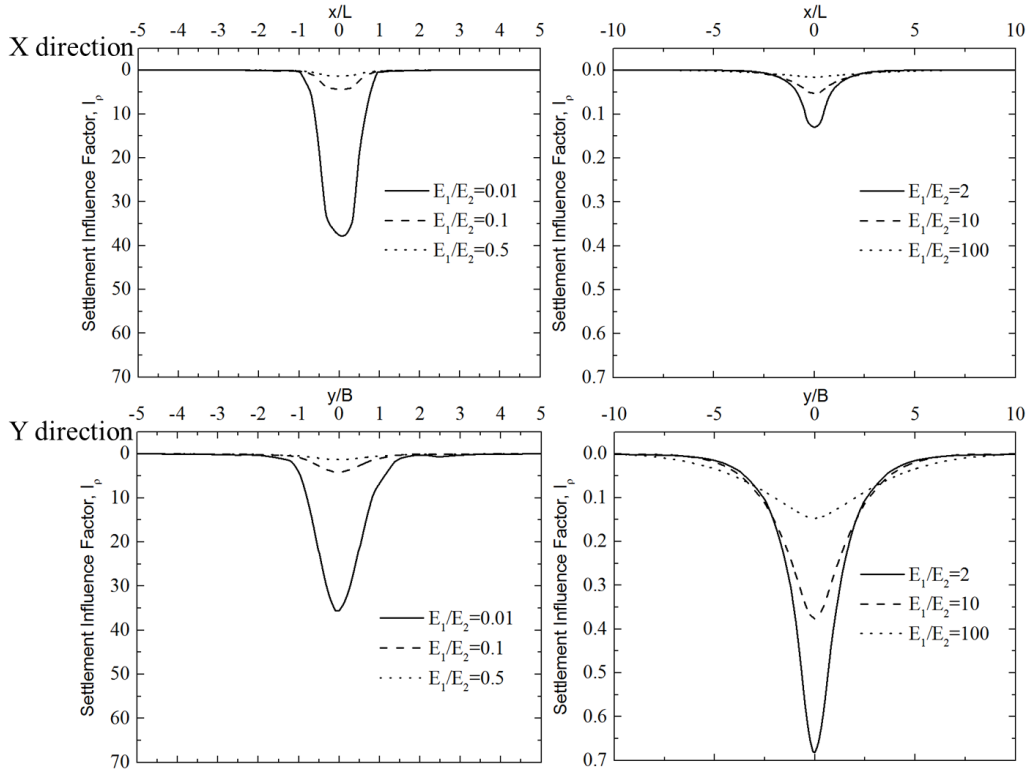

Figure 8.12 Settlement Influence Factor Profile at $D/B=0.5$ for $D/B=0.5$, $L/B=2$, $H_1/B=1$ and $H_2/B=4$ in the x and y direction

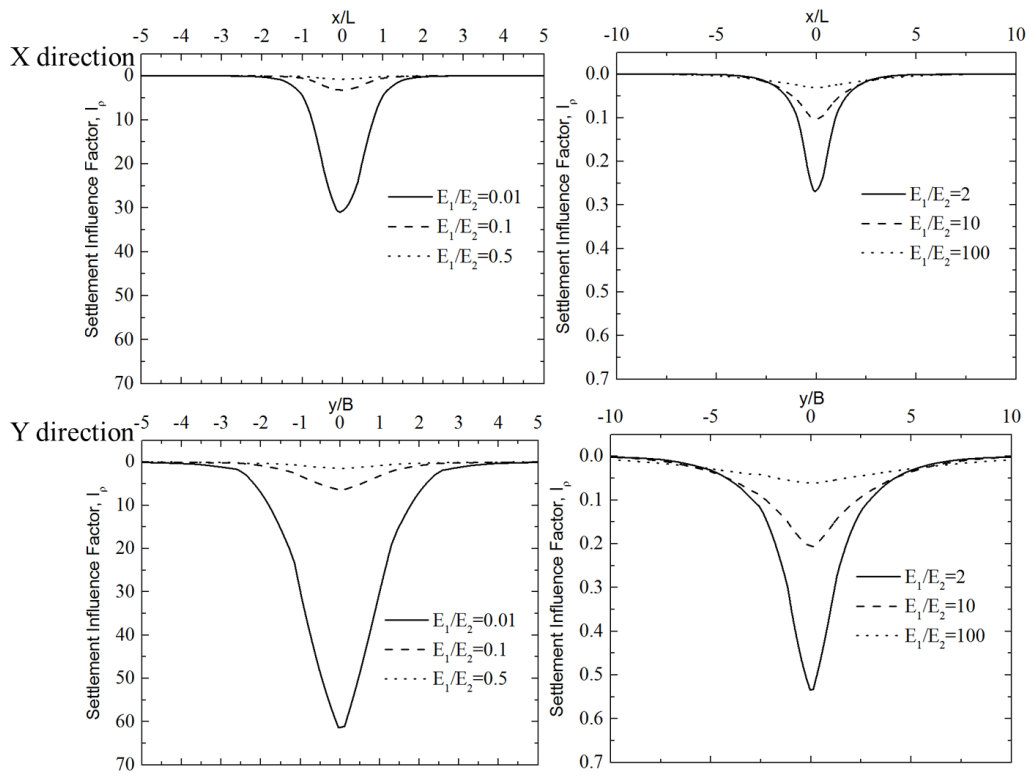

Figure 8.13 Surface Settlement Influence Factor Profile for $D/B=0.5$ for $D/B=0.5$, $L/B=2$, $H_1/B=2$ and $H_2/B=4$ in the x and y direction

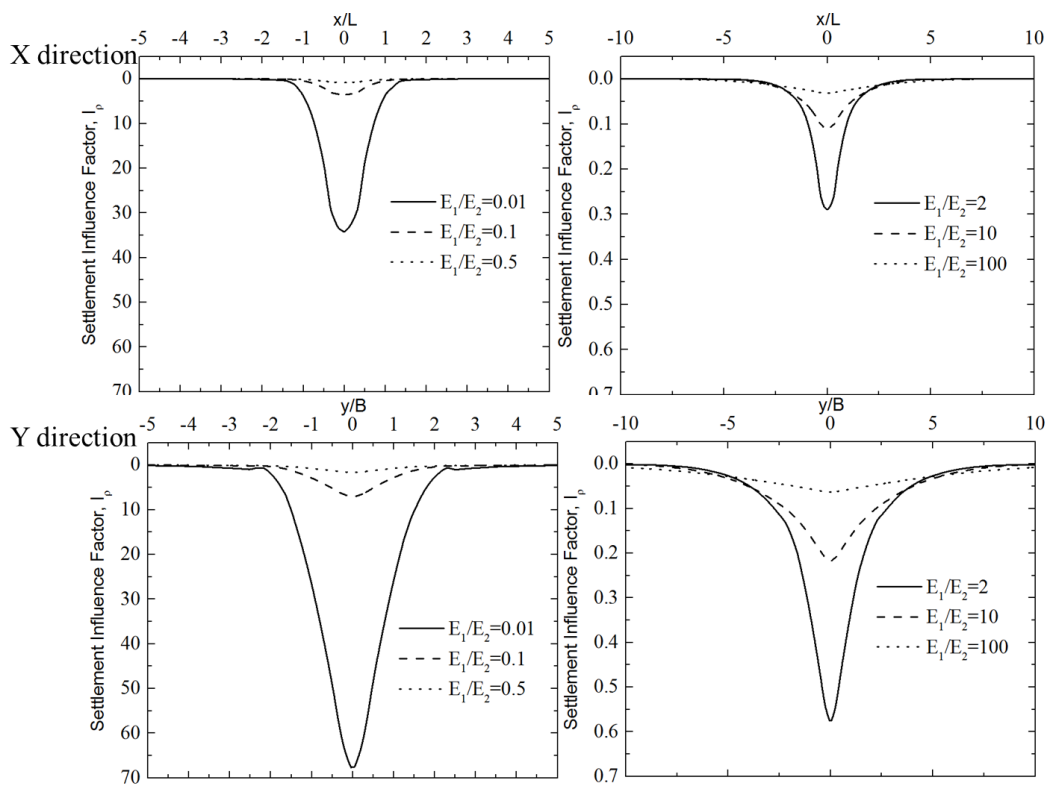

Figure 8.14 Settlement Influence Factor Profile at $D/B=0.5$ for $L/B=2$, $H_1/B=2$ and $H_2/B=4$ in the x and y direction

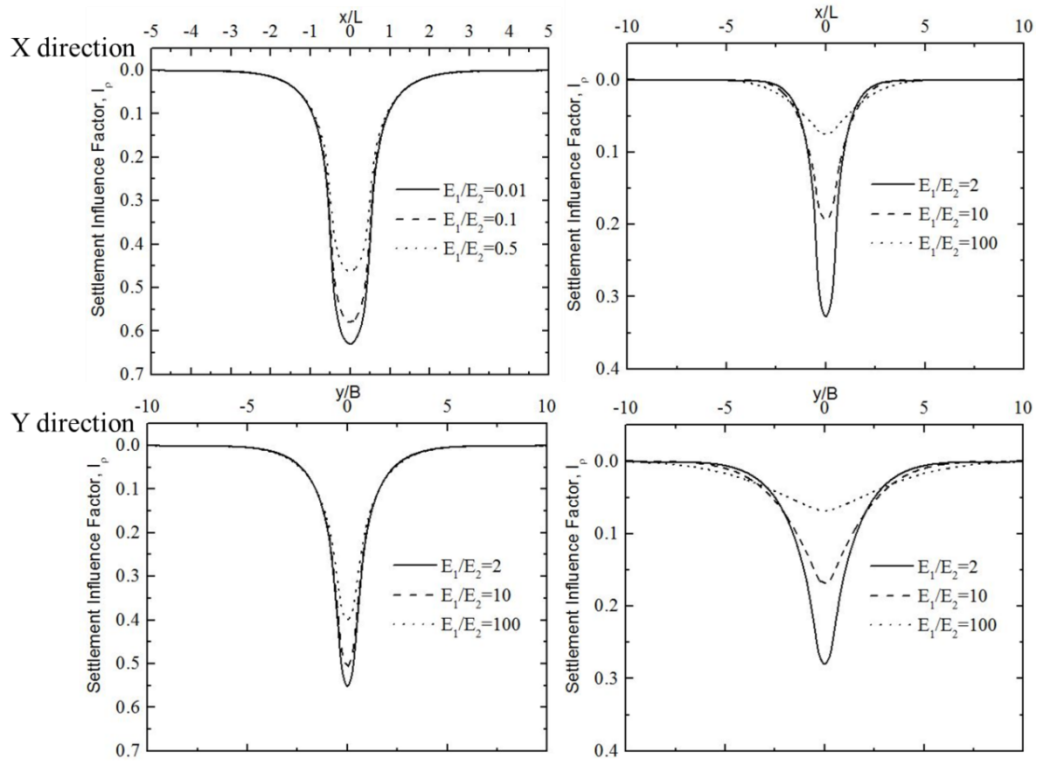

Figure 8.15 Surface Settlement Influence Factor Profile for $D/B=1$ for $L/B=2$, $H_1/B=1$ and $H_2/B=4$ in the x and y direction

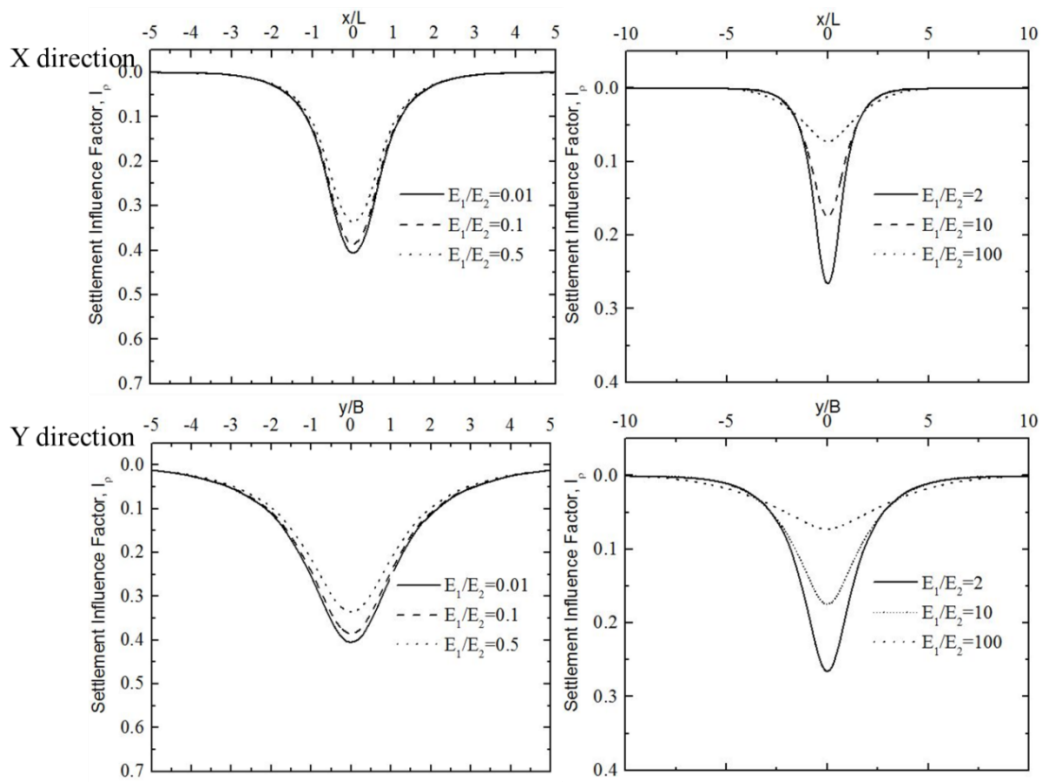

Figure 8.16 Settlement Influence Factor Profile at $D/B=1$ for $D/B=1$ for $L/B=2$, $H_1/B=1$ and $H_2/B=4$ in the x and y direction

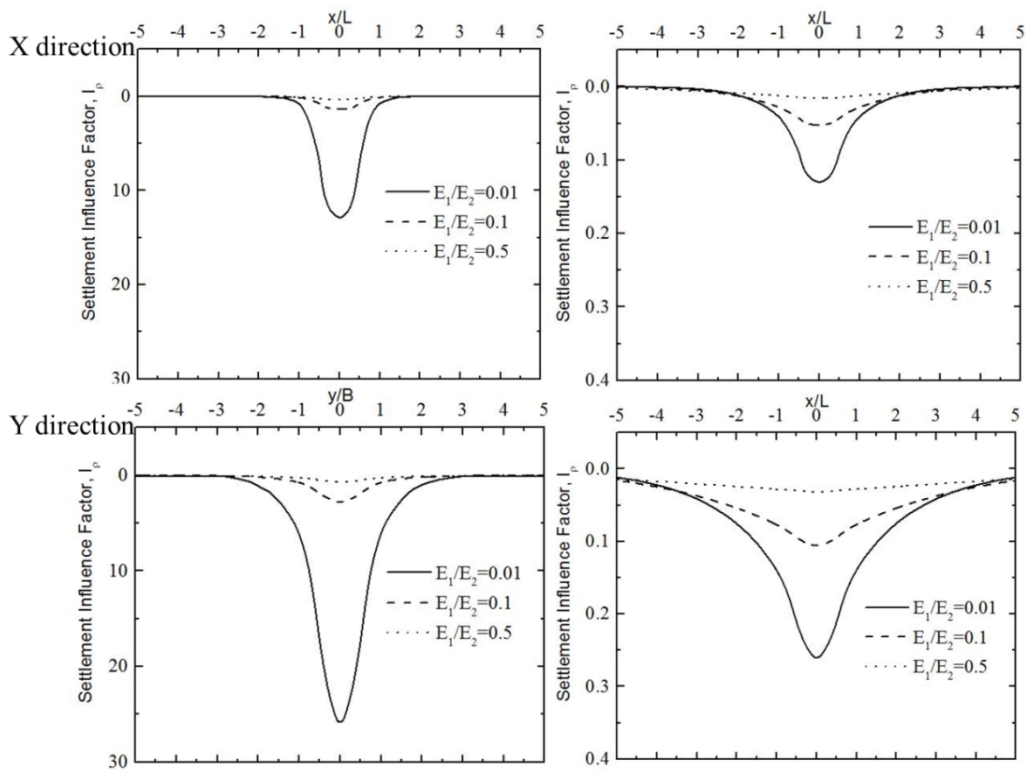

Figure 8.17 Surface Settlement Influence Factor Profile for $D/B=1$ for $L/B=2$, $H_1/B=2$ and $H_2/B=4$ in the x and y direction

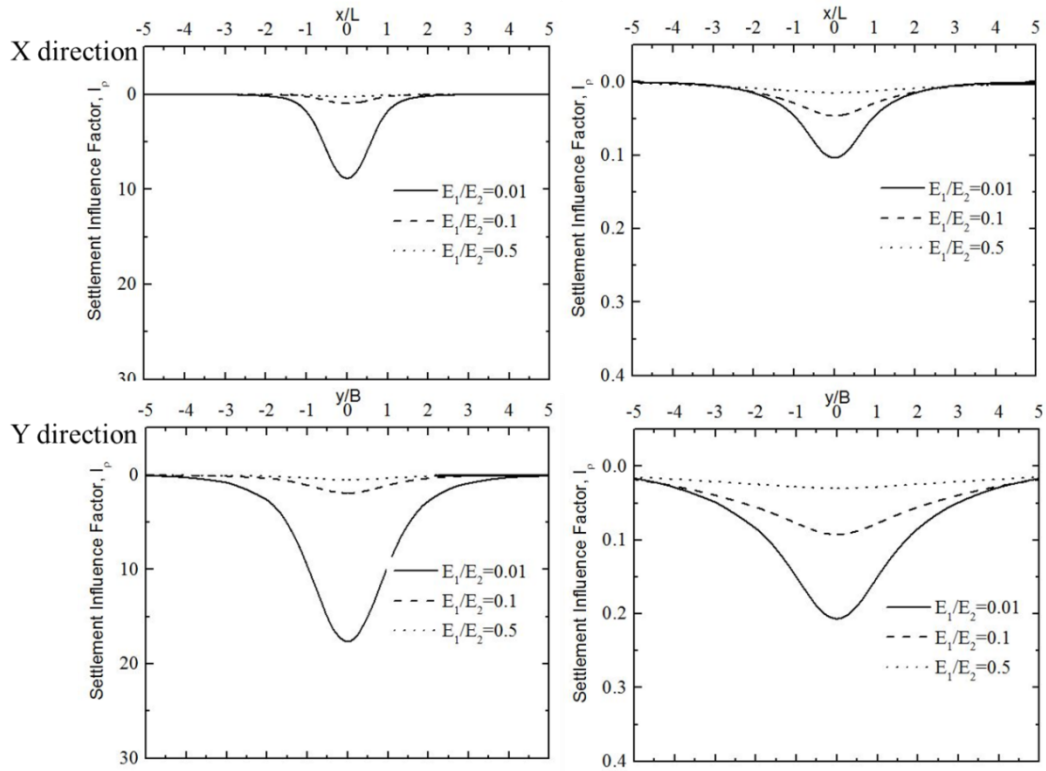

Figure 8.18 Settlement Influence Factor Profile at $D/B=1$ for $D/B=1$ for $L/B=2$, $H_1/B=2$ and $H_2/B=4$ in the x and y direction

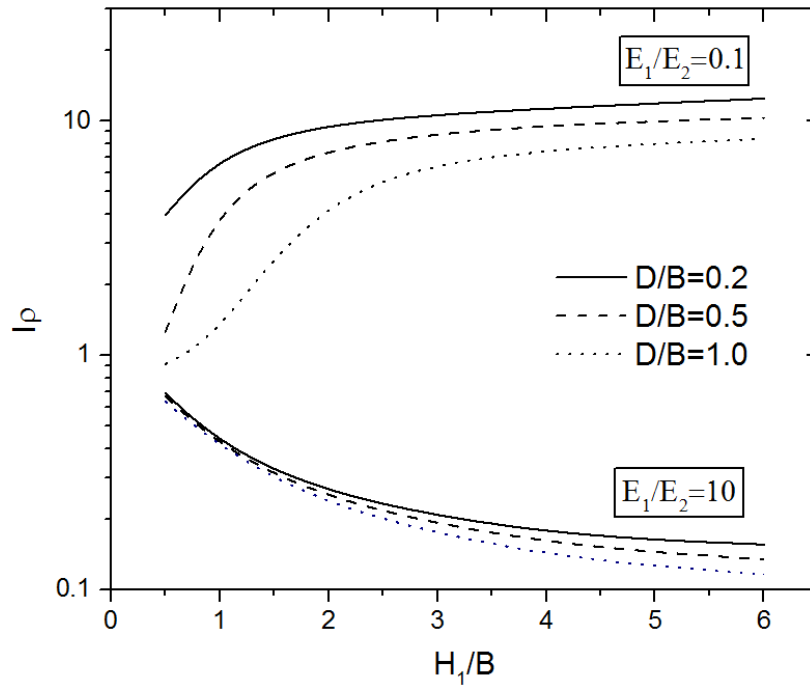

Figure 8.19 Comparison of Settlement Influence Factor for various Depths of Embedment for $E_1/E_2=0.1$ and 10, for $L/B=2$, $H_1/B=1$ and $H_2/B=4$

Figure 8.19 shows comparison of the effects of the depth of embedment for D/B of 0.2, 0.5 and 1 for parameters of $L/B=2$, $H_1/B=1$, $E_1/E_2=0.1$ and 10, and $H_2/B=4$. From the graph we can see that as the depth of embedment increases, the settlement decreases. The decrease in settlement is more pronounced when the top layer is less stiff. The stiffer layer provides more resistance and therefore the depth of embedment is less effective. The rate of change increases for lower stiffness ratio, i.e. the top layer is less stiff. For a D/B of 0.2, the settlement can be studied from the initial thickness of the footing, while for $D/B=1$, the settlement factor is very less until the thickness of the footing reaches depth of embedment.

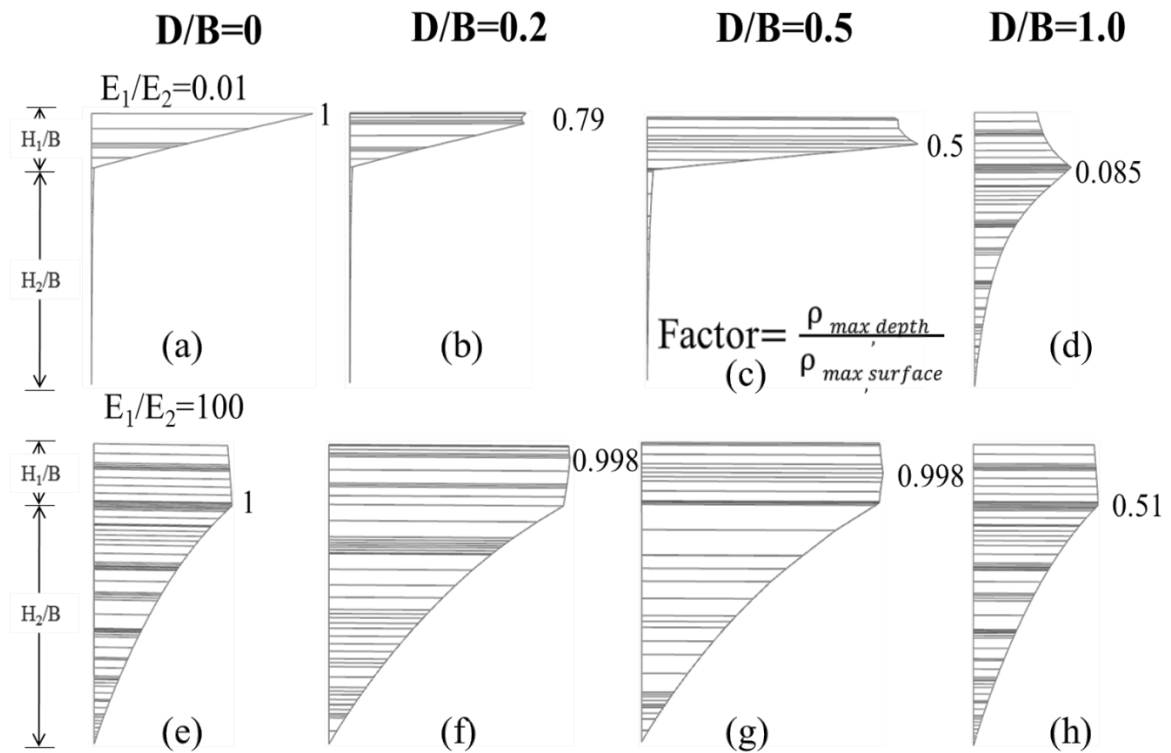

Figure 8.20 Vertical Variation of Displacement along the z direction for various Depths of Embedment for $E_1/E_2=0.01, 100, H_1/B=1$ and $H_2/B=4$

8.5 Settlement at the Centre along the Depth

The variation of settlement along the depth at the centre of the footing can be understood from figure 8.20, where settlements along the depth are plotted for various D/B values for two cases of E_1/E_2 less than and greater than 1. The settlements are compared to the settlements obtained when the footings are placed at the surface of the footing. The model dimensions are kept as a constant to fully understand the influence, the depth of embedment has on settlements.

Figures 8.20(a), (b), (c) and (d) represent the settlements for E_1/E_2 less than 1. Since the top layer is easily compressible, the settlements are seen to in the top layer of the soil for the cases of $D/B=0, 0.2$ and 0.5 . However for the case of $D/B=1$, we can see

that the footing comes to rest in the top of the bottom layer of the footing and all the impact is seen mostly on the bottom layer of the soil. We can also see that the settlements obtained is 0.085 times the settlement obtained at the surface in this condition. The stiffer layer takes the load incurred by the soil and therefore the settlement values are found to be very less.

Figures 8.20(e), (f), (g) and (h) represent the settlements for E_1/E_2 more than 1. Since the top layer is stiffer, the settlements are seen to in the top layer of the soil for all the cases, however, the settlements are seen to extend into the bottom layer too. The less stiff layer compresses due to the load taken by the soil layers and the stiffer layer as surcharge, however, the effect of the applied load is lessened by the presence of the top layer. We can also see that the settlements obtained is half the settlement obtained at the surface in the condition of $D/B=1$. The stiffer layer takes the load incurred by the soil but the displacements are still found in the bottom layer in this case.

Chapter 9

Conclusions

In this study, the settlements of the two layered soil system underlain by a rigid base for a rectangular footing was analysed using PLAXIS 3D for a wide range of geometric and soil properties. Validations are provided and the result obtained from validation are in good agreement with the results proposed.

The effect of Poisson's ratio is analysed for all the conditions and the results are compared with the analytical solutions obtained by Razouki(2009) approximated from Boussinesq's equation as defined in Chapter 4.

- The effect of Poisson's ratio is very minimal in linear elastic study as the value obtained is very close to the results obtained.
- The effect, if needed, can be taken into consideration by the approximation solution defined by Razouki(2009)
- The approximations are valid only if the top and the bottom layers have the same Poisson's ratio

Settlement of a finite two-layered soil system due to uniform rectangular loading is obtained using finite elements for a wide range of geometric and soil properties in Chapter 5.

- The settlements from the proposed finite element model are validated and found to be in good agreement with the field measurements on building sites located in Adelaide, Australia, and Ontario, Canada.
- Both the cases of a soft layer overlying a stiff layer ($E_1/E_2 < 1.0$) and a stiff layer overlying a soft layer ($E_1/E_2 > 1.0$) are considered.

- Design engineers can use the settlement influence factors proposed in the form of charts to estimate the settlement at the centre of the loading.
- For uniformly loading on rectangular area, the aspect ratio of the area higher than 2.5 (i.e., $L/B > 2.5$) was found to have an insignificant effect on the settlement influence factor at the centre of loading of the layered system.
- The thickness of the top layer was found to have significant effect on the settlements for H_1/B within about 2.5, hence the rate of change of maximum settlement influence factor with H_1/B becomes negligible for $H_1/B > 2.5$.
- The settlement influence factor was found to decrease only slightly with increase in the Poisson's ratio.
- The extent of surface settlement of layered system is presented by plotting the variation of surface settlement influence factors in x and y directions. The settlements are found to extend to a larger distance for the case with soft layer overlying stiff layer.

Conversion of area of rectangular footing into equivalent area of circular footing was analysed as proposed by various researchers as explained in Chapter 6.

- The conversion is valid if and only if,
 - The soil is a semi-infinite strata and
 - The footing has L/B ratio less than or equal to 2
- It is also to be noted that conversion of circular footing to equivalent area of square footing or vice versa always gives results within acceptable errors.
- When the top layer thickness is less than the influence of the pressure bulb of either footing for a footing (or equivalent area of footing) with one finite layer of soil, then the conversion factor will not generally work.

The settlement influence factors have been introduced for rigid footing for finite layer underlain by a rigid base and a two layered soil system underlain by the rigid base in Chapter 7.

- Validation was done with results proposed by US Navy Manual() for an infinite layer of soil layer and found to be in good agreement.
- Settlement influence factors were proposed in the form of charts for rigid footings for varying dimensions and properties.
- The factors were compared to the factors for a flexible footing of a particular set of parameters.

Settlement of a finite two-layered soil system due to uniform rectangular loading embedded at a certain depth is obtained using finite elements for a wide range of geometric and soil properties in Chapter 8.

- The settlements from the proposed finite element model embedded at a depth are validated and found to be in good agreement with the field measurements on building in Ontario, Canada.
- Both the cases of a soft layer overlying a stiff layer ($E_1/E_2 < 1.0$) and a stiff layer overlying a soft layer ($E_1/E_2 > 1.0$) are considered.
- Design engineers can use the settlement influence factors proposed in the form of charts to estimate the settlement at the centre of the loading at a depth.
- The extent of surface settlement of layered system is presented by plotting the variation of surface settlement influence factors in x and y directions. The settlements are found to extend to a larger distance for the case with soft layer overlying stiff layer.
- From the results presented, we can see that as the depth of embedment increases, the settlement decreases. The decrease in settlement is more pronounced when the top layer is less stiff.
- The effect of the embedded load is also studied along the z direction and compared with the settlements obtained for loading at the surface.

The design charts proposed help designers determine the maximum settlement incurred and the extent of influence of the particular loading in the x and y direction.

Various other conditions have also been incorporated, like the depth of embedment and rigidity of the footing, necessary for the engineer to design without approximating the given parameters. The charts are proposed for a wide range of geometric and physical properties, from which the other values can be interpolated. The validations and the limitations of various cases have also been discussed.

References

1. Ai, Zhi Yong, and Jian Bang Cai. (2015). "Static analysis of Timoshenko beam on elastic multilayered soils by combination of finite element and analytical layer element." *Applied Mathematical Modelling*, 39 (7), 1875-1888.
2. Ai, Zhi Yong, and Yi Fan Zhang. (2015). "The analysis of a rigid rectangular plate on a transversely isotropic multilayered medium." *Applied Mathematical Modelling*, 39(20), 6085-6102.
3. Anbazghan, P., and Sitaram, T.G. (2006). "Evaluation of dynamic properties and ground profiles using MASW: Correlation between Vs and N60." 13th Symposium on Earthquake Engineering, Indian Institute of Technology, Roorkee, Paper no. 008.
4. Azam, G., Hsieh, C. W., and Wang, M. C. (1991). "Performance of strip footing on stratified soil deposit with void." *Journal of Geotechnical Engineering*, 117(5), 753-772.
5. Boussinesq, J. (1885). "Application des potentials à l'étude de l'équilibre et du mouvement des solides élastiques." Gauthier-Villars, Paris.
6. Brzakala, W., Pula, W., and El-Meligy, M. (1995). "Settlement analysis by non-linear finite element method." In *Applications of Statistics and Probability*, Proc. of the ICASP 7 Conference, Rotterdam, Balkema, Paris, 55-63.
7. Burmister, D. M. (1945). "The general theory of stresses and displacements in layered systems." *International Journal of Applied Physics*, 16(2), 89-94.
8. Burmister, D. M. (1962). "Application of layered system concepts and principles to interpretations and evaluations of asphalt pavement performances and to design and construction." *Proceedings of International Conference on Structural Design of Pavements*, University of Michigan, 441-453.
9. Chakraborty D and Kumar J, Feb 2013, 'Dependency of N_7 on footing diameter for circular footings', Elsevier, The Japanese Geotechnical Society peer reviewed, *Soils and Foundations* Vol. 53, Issue 1, page 173–180
10. Conte, E., and Dente, G. (1993). "Settlement analysis of layered soil systems by stiffness method." *Journal of Geotechnical Engineering*, 119(4), 780-785.
11. Davis, E. H., and Taylor, H. (1962). "The movement of bridge approaches and abutments on soft foundation soils." *Proceedings of 1st Biennial Conference*, Australian Road Research Board, 740-764.

12. Enkhtur, O, T D Nguyen, J M Kim and S R Kim, 2013, 'Evaluation of the Settlement Influence Factors of Shallow Foundation by Numerical Analyses', *KSCE Journal of Civil Engineering*, Springer, Vol. 17, Issue 1, page 85-95
13. Fellenius B. H. , Jan 2006, 'Basics of Foundation Design', Electronic Edition
14. Fraser, F. R., and Wardle, L. J. (1976). "Numerical analysis of rectangular rafts on layered foundations." *Geotechnique*, 26(4), 613- 630.
15. Gerrard, C. M. (1969). "Tables of stresses, strains and displacements in two- layer elastic systems under various traffic loads." Australian Road Research Board, Special Report No. 3.
16. Giroud, J. P. (1968). "Settlement of a linearly loaded rectangular area." *Journal of Soil Mechanics Division, ASCE*, 94(4), 813- 831.
17. Harr, M. E. (1966). "Foundations of theoretical soil mechanics." McGrawHill, New York.
18. Kay, J. N., and Cavagnaro, R. L. (1983). "Settlement of raft foundations." *Journal of Geotechnical Engineering, ASCE*, 10.1061/(ASCE)0733-9410(1983)109:11(1367), 1367- 1382.
19. Kelvin, L. (1848). "Note on the integration of the equations of equilibrium of an elastic solid." *Cambridge and Dublin Mathematical Journal*, 3, 87-89.
20. Maheshwari, Priti. (2015). "Settlement of shallow footings on layered soil: state-of-the-art." *International Journal of Geotechnical Engineering*, 9(1), 42-48.
21. Mayne P W and H G Poulos, June 1999, 'Approximate Displacement Influence Factors for Elastic Shallow Foundations', *Journal of Geotechnical and Geoenvironmental Engineering*, Vol. 125, No. 6, Paper No. 18524
22. Milovic, D. M., and Tournier, J. P. (1971). "Stresses and displacements due to rectangular load on a layer of finite thickness." *Soils and Foundations*, 11(1), 1-27.
23. Palmer, L. A., and Barber, E. S. (1940). "Soil displacement under a circular loading area." *Proceedings of Highway Research Board*, 20, 279-286.
24. Poulos, H. G., and Davis, E. H. (1974). "Elastic solutions for soil and rock mechanics." Wiley & Sons, New York, University of Sydney Press.
25. Prakash S , V K Puri, May 2006, 'Foundations for Vibrating Machines', Special Issue, *Journal of Structural Engineering*, SERC, India
26. Razouki, S. S., and Al-Zubaidy, D. A. (2010). "Elastic settlement of square footings on a two layer deposit." *Proceedings of the Institution of Civil Engineers*, 163(2), 101- 106.
27. Reference and Scientific manuals, PLAXIS version AE (2013)

28. Salgado R., *The Engineering of Foundations*, Tata McGraw Hill, 2011 Edition.
29. Shvets, V. B., Kh Khalaf, Z. Sal'kha, and Gorlach, S. N. (2003). "Experimental investigation and analysis of the settlement funnel in beds supporting different types of foundations." *Soil Mechanics and Foundation Engineering*, 40(6), 215-219.
30. Sieffert J G , 1996, 'What is Missing for using in Practice Available Results on Foundation impedances', Elsevier, Eleventh World Conference on Earthquake Engineering, Paper 2075
31. *Soil and Foundations Design Manuals* (1986), US Navy, Washington D. C., DM-7.1
32. Sovinc, I. (1961). "Stresses and displacements in a limited layer of uniform thickness, resting on a rigid base, and subjected to a uniformly distributed flexible load of rectangular shape." *Proceedings of 5th ICOSOMEF*, 823-827.
33. Sovinc, I. (1969), *Displacements and Inclinations of Rigid Footings Resting on a Limited Elastic Layer of Uniform Thickness*, *Proceedings of 7th International Conference on Soil Mechanics and Foundation Engineering*, Vol. 1, page 121
34. Suchomel, R., and Mašín, D. (2011). "Probabilistic analyses of a strip footing on horizontally stratified sandy deposit using advanced constitutive model." *Computers and Geotechnics*, 38(3), 363-374.
35. Thenn de Barros, S. (1966). "Deflection factor charts for two and three-layer elastic systems." *Highway Research Record*, 145, 83-108.
36. Trow, W., and Bradstock, J. (1972). "Instrumented foundations for two 43- storey buildings on till, metropolitan Toronto." *Canadian Geotechnical Journal*, 9, 290-303.
37. Ueshita, K., and Meyerhof, G. G. (1967). "Deflection of multilayer soil systems." *Journal of Soil Mechanics and Foundation Division, ASCE*, 93(5), 257-282.
38. Ueshita, K., and Meyerhof, G. G. (1968). "Surface displacements of an elastic layer under uniformly- distributed loads." *Highway Research Record* 228, National Research Council, 1-10.
39. Umashankar B., Yugandhar, D. and Madhav, M. R., 2013, 'Settlement Due to Uniform Circular Load: On Finite Two-Layer System', *Geotechnical and Geological Engineering*, Springer, Volume 31, Issue 1, page 255
40. Vesic, A. S. (1963). Discussion, Session III, *Proceedings of 1st International Conference of Structural Design of Asphalt Pavements*, University of Michigan, 283- 290.
41. Wang, C. M., Chow, Y. K., and How, Y. C. (2001). "Analysis of rectangular thick rafts on an elastic half-space." *Computers and Geotechnics*, 28(3), 161-184.

42. Whitman R. V. and Rickart F. E. (1967), Design Procedure for Dynamically Loaded Foundations, Journal of Soil Mechanics and Foundations Division, ASCE, Vol. 93, No. SM6, page 169- 193
43. Zhang, L. M., and Dasaka, S. M. (2010). “Uncertainties in geological profiles versus variability in pile founding depth.” Journal of Geotechnical and Geoenvironmental Engineering Division, ASCE, 10.1061/(ASCE)GT.1943-5606.0000364, 1475- 1488.