

## Kinematics and bearing capacity of strip footing on RFB over compressible ground stabilized with granular trench

Sakleshpur Venkata Abhishek<sup>i)</sup>, Rajyalakshmi Kurapati<sup>ii)</sup> and Madhira R. Madhav<sup>iii)</sup>

i) Research Scholar, School of Civil Engineering, Purdue University, West Lafayette, Indiana 47907, USA.

ii) Lecturer (Selection grade), Department of Technical Education, Bheemunipatnam, Visakhapatnam 531163, India.

iii) Professor Emeritus, JNT University & Visiting Professor, IIT, Hyderabad 500034, India.

### ABSTRACT

The paper presents a method to estimate the bearing capacity of a strip footing on a geosynthetic reinforced foundation bed (RFB) laid over soft compressible ground stabilized with granular trench. Madhav and Vitkar's solution for bearing capacity of granular trench-supported footing in soft ground, Vesic's cavity expansion theory that considers the compressibility/stiffness of soft ground together with its undrained shear strength and the effect of kinematics (the effect of the transverse resistance in addition to the axial resistance of the reinforcement, Madhav and Umashankar) are incorporated in Meyerhof's analysis for layered soils, to arrive at the ultimate capacity of the reinforced foundation bed-granular trench system. A parametric study quantifies the effects of various parameters on the bearing capacity of the strip footing. Consideration of compressibility/stiffness of soft ground together with kinematics of failure indicates relatively enhanced values of bearing capacity of footing over those corresponding to incompressible ground or reinforced two-layered system considering axial resistance of reinforcement alone. Predictions compare well with experimental results in literature.

**Keywords:** compressibility, bearing capacity ratio (BCR), granular trench, granular fill, geosynthetic reinforcement

### 1 INTRODUCTION

Soft ground, widespread throughout the world along deltaic and coastal regions, possess poor geotechnical properties such as high natural moisture content (close to liquid limit), high compressibility, low undrained shear strength and hydraulic conductivity. Most studies for estimation of bearing capacity of a reinforced granular fill over soft ground consider the latter to behave as a rigid-plastic and incompressible material. However, ground/soil being a highly complex entity than metals from which conventional bearing capacity theories have been developed, requires consideration of the stiffness/compressibility of the ground together with its shear strength for the estimation of ultimate loads.

### 2 LITERATURE REVIEW

Vesic (1972) proposed a general expression for the ultimate cavity pressure,  $p_u$ , by accounting for the compressibility of the ground/soil. Madhav and Vitkar (1978) proposed a solution for the bearing capacity of a strip footing on granular trench-reinforced ground considering a general shear failure mechanism. Hamed *et al.* (1986) presented laboratory model test results for the ultimate bearing capacity of a surface strip foundation installed in soft ground and supported by a

granular trench of the same width as the foundation. Unnikrishnan and Rajan (2012) studied the influence of providing a Granular Trench (GT) below strip footings on loose sand deposits. Abhishek *et al.* (2014) presented a method for the estimation of bearing capacity of a strip footing on a geosynthetic-reinforced foundation bed over soft homogeneous ground stabilized with granular trench.

### 3 PROBLEM DEFINITION & FORMULATION

A strip footing of width,  $B$ , is embedded at depth,  $D_f$ , below the ground surface in a reinforced granular fill of thickness,  $H$ , over compressible ground stabilized with granular trench of width,  $B_r$ . (Fig. 1). The cohesion, angle of shearing resistance and unit weight of the trench material are  $c_1$ ,  $\phi_1$  and  $\gamma_1$  respectively. The shear modulus, undrained shear strength and unit weight of compressible ground are  $G$ ,  $s_u$  and  $\gamma_2$  respectively. The angle of shearing resistance and unit weight of the granular fill are  $\phi$  and  $\gamma$  respectively. A single layer of geosynthetic reinforcement of length,  $L_r$ , is placed just above the granular fill-compressible ground interface, within the granular fill. The interface/bond resistance between the reinforcement and the fill is  $\phi_r$  and the axial tension mobilized in the reinforcement is  $T_R$ .

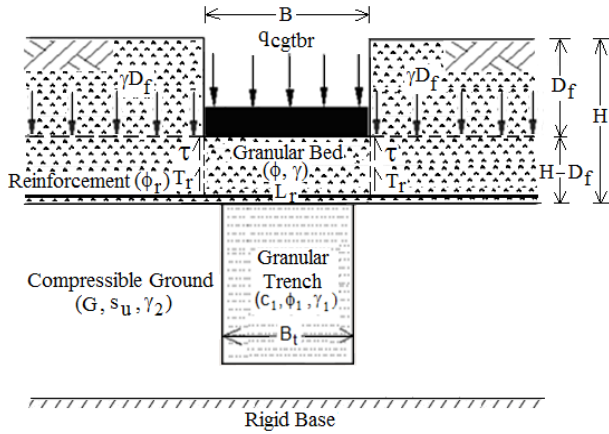

Fig. 1. Definition sketch of strip footing on reinforced granular bed over compressible ground with granular trench.

Vesic (1972) proposed a general expression for the ultimate cavity pressure,  $p_u$ , based on the expansion of a cylindrical cavity in cohesionless soil under conditions of zero average volumetric strain, by accounting for the compressibility of the ground/soil as

$$p_u = N_c^* s_u + q_0 \quad (1)$$

where  $N_c^* = (\ln I_r + 1)$ ,  $I_r = G/s_u$  – the relative rigidity index and  $q_0$  – the overburden pressure.

Madhav and Vitkar (1978) proposed a solution for the ultimate bearing capacity of a strip footing in soft ground stabilized with granular trench considering general shear failure mechanism along with Coulomb's criterion for yielding of soils (Fig. 2). The ultimate bearing capacity,  $q_{u,f}$ , of strip footing in soft ground stabilized with granular trench is

$$q_{u,f} = c_2 N_c + \left(\frac{\gamma_2 B}{2}\right) N_\gamma + D_f \gamma_2 N_q \quad (2)$$

where

$$N_c = \frac{c_1}{c_2} N_{c1} + N_{c2} \quad (3)$$

$$N_\gamma = \frac{\gamma_1}{\gamma_2} N_{\gamma1} + N_{\gamma2} \quad (4)$$

$N_{c1}$ ,  $N_{c2}$ ,  $N_{\gamma1}$ ,  $N_{\gamma2}$  and  $N_q$  are dimensionless factors that depend on the geotechnical properties of the trench and soft soil materials and the ratio  $B_f/B$ . Values of the bearing capacity factors  $N_c$ ,  $N_q$  and  $N_\gamma$  have been given by Madhav and Vitkar (1978) for varying values of  $B_f/B$  and  $\phi_1$ .

Meyerhof (1974) proposed punching mode of failure for strip footing of width,  $B$ , and depth,  $D$ , resting on relatively thin, dense sand stratum of thickness,  $H$ , with angle of shearing resistance,  $\phi$  and unit weight,  $\gamma$ , overlying thick soft clay with undrained cohesion,  $c$ . A total passive force,  $P_p$ , inclined at an angle,  $\delta$ , acts on vertical plane through footing edge. The possible failure modes of the footing, namely, punching shear through relatively thin sand layer (Fig. 3a) and general shear failure within thick sand layer alone (Fig. 3b) are shown.

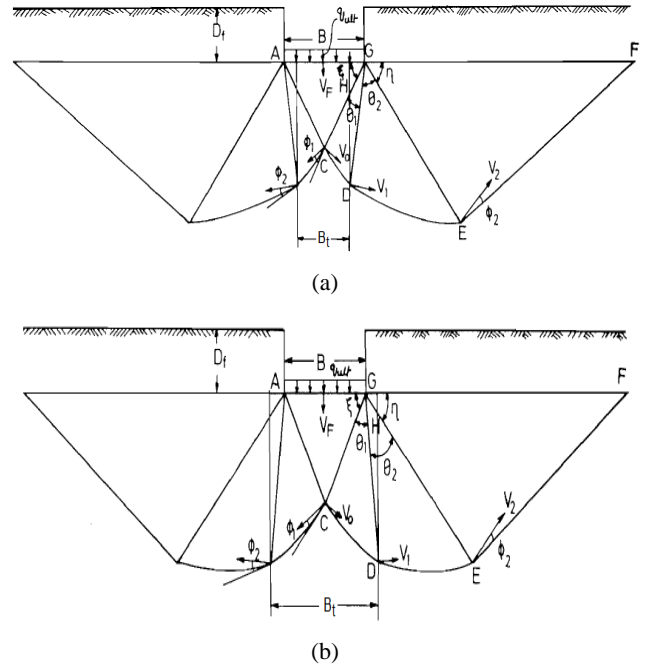

Fig. 2. Failure mechanisms for strip footing in soft ground with granular trench (a)  $B_f/B \leq 1$  and (b)  $B_f/B \geq 1$  (after Madhav and Vitkar, 1978).

As the footing punches through the sand layer into soft clay, shear stresses are developed on either sides of the sand column. The ultimate bearing capacity,  $q_u$ , of a strip footing in dense sand overlying soft clay is

$$q_u = c N_c + \frac{\gamma H^2}{B} \left(1 + \frac{2D}{H}\right) K_s \tan \phi + \gamma D \quad (5)$$

limited by the ultimate bearing capacity of a thick deposit of sand as

$$q_t = \gamma D N_q + 0.5 \gamma B N_\gamma \quad (6)$$

where  $K_s$  is the coefficient of punching shearing resistance;  $N_c$  (equal to 5.14 for soft clay with  $\phi_u = 0$ ),  $N_q$  and  $N_\gamma$  are Meyerhof's bearing capacity factors.

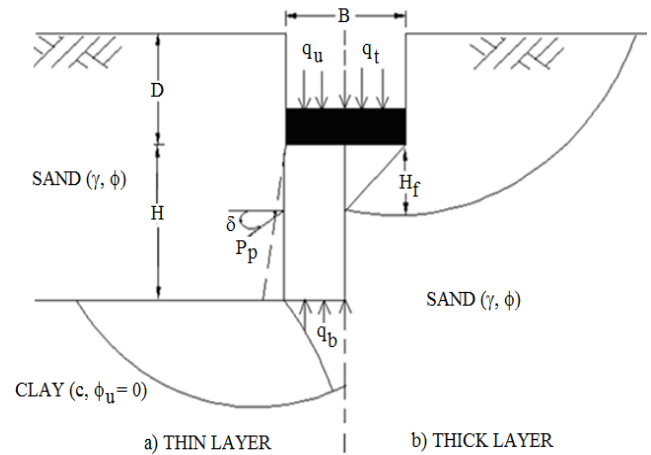

Fig. 3. Failure mechanism for strip footing in dense sand over soft clay (after Meyerhof 1974).

### 3.1 Bearing capacity of strip footing on granular bed over compressible ground with granular trench

The ultimate bearing capacity,  $q_{cgt}$ , of a strip footing in compressible ground stabilized with granular trench is obtained by incorporating Vesic's expression in Madhav and Vitkar's solution, as

$$q_{cgt} = s_u \left[ \ln \left( \frac{G}{s_u} \right) + 1 \right] + 0.5\gamma_2 B N_\gamma + \gamma D_f N_q \quad (7)$$

where  $N_q$  and  $N_\gamma$  are Madhav and Vitkar's bearing capacity factors. Normalizing Eq. (7) with the undrained shear strength of compressible ground,  $s_u$ , the normalized ultimate bearing capacity,  $N_{cgt}$ , of a strip footing in compressible ground stabilized with granular trench is

$$N_{cgt} = \left[ \ln \left( \frac{G}{s_u} \right) + 1 \right] + 0.5 \left( \frac{\gamma_2 B}{s_u} \right) N_\gamma + \left( \frac{\gamma B}{s_u} \right) \left( \frac{D_f}{B} \right) N_q \quad (8)$$

The ultimate bearing capacity,  $q_{cgtb}$ , of a strip footing in a two-layered system of granular fill over compressible ground stabilized with granular trench is obtained by coupling equations (1), (2) and (5), as

$$q_{cgtb} = s_u \left[ \ln \left( \frac{G}{s_u} \right) + 1 \right] + 0.5\gamma_2 B N_\gamma + \frac{\gamma H^2}{B} \left( 1 + \frac{2D_f}{H} \right) K_s \tan \varphi + \gamma D_f N_q \quad (9)$$

where  $K_s$  is the coefficient of punching shearing resistance—a function of the angle of shearing resistance of the granular fill,  $\varphi$ , and the ratio  $q_2/q_1$  where  $q_1$  and  $q_2$  are the ultimate bearing capacities of a strip footing on the surface of a thick granular bed and granular trench-stabilized compressible ground respectively. The ratio  $q_2/q_1$  is given by

$$\frac{q_2}{q_1} = \frac{s_u \left[ \ln \left( \frac{G}{s_u} \right) + 1 \right] + 0.5\gamma_2 B N_\gamma}{0.5\gamma B N_\gamma} \quad (10)$$

where  $N_\gamma$  in the numerator corresponds to that of Madhav and Vitkar (1978) while  $N_\gamma$  in the denominator is Meyerhof's bearing capacity factor. Considering the total thickness of the granular fill as  $H$  (Fig. 1), Eq. (9) gets modified as

$$q_{cgtb} = s_u \left[ \ln \left( \frac{G}{s_u} \right) + 1 \right] + 0.5\gamma_2 B N_\gamma + \frac{\gamma(H^2 - D_f^2)}{B} K_s \tan \varphi + \gamma D_f N_q \quad (11)$$

Normalizing Eq. (11) with the undrained shear strength of compressible ground,  $s_u$ , the normalized ultimate bearing capacity,  $N_{cgtb}$ , of a strip footing in a two-layered system of granular fill over compressible ground stabilized with granular trench, is

$$N_{cgtb} = \left[ \ln \left( \frac{G}{s_u} \right) + 1 \right] + 0.5 \left( \frac{\gamma_2 B}{s_u} \right) N_\gamma + \left( \frac{\gamma B}{s_u} \right) \left\{ \left[ \left( \frac{H}{B} \right)^2 - \left( \frac{D_f}{B} \right)^2 \right] K_s \tan \varphi + \left( \frac{D_f}{B} \right) N_q \right\} \quad (12)$$

### 3.2 Bearing capacity of strip footing on reinforced granular bed over compressible ground with granular trench

#### Axial pull

Figures 4a & b depict the stresses developed in the reinforced granular column and the geosynthetic reinforcement respectively, due to punching of the footing through the reinforced granular bed into compressible ground. The axial tension developed in the reinforcement layer of length,  $L_r$ , is due to interface shear resistance mobilized over the top and bottom surfaces of the reinforcement (Fig. 4). The length of the reinforcement beyond the edge of the footing,  $(L_r - B)/2$ , is considered to be effective in contributing to the interface shear resistance mobilized by the reinforcement. The axial tension,  $T_R$ , developed in the reinforcement on either side of the footing, due to shear stresses developed over the surface of the reinforcement at the granular fill-compressible ground interface is

$$T_R = \gamma H \tan \varphi_r \frac{(L_r - B)}{2} \quad (13)$$

The ultimate bearing capacity,  $q_{cgtbr}$ , of a strip footing in a two-layered system of reinforced granular fill over compressible ground stabilized with granular trench (Fig. 1), is obtained by adding the contribution of the axial resistance of the geosynthetic reinforcement to pull-out to Eq. 11 as

$$q_{cgtbr} = s_u \left[ \ln \left( \frac{G}{s_u} \right) + 1 \right] + 0.5\gamma_2 B N_\gamma + \frac{\gamma(H^2 - D_f^2)}{B} K_s \tan \varphi + \gamma D_f N_q + \frac{\gamma H}{B} \tan \varphi_r (L_r - B) \quad (14)$$

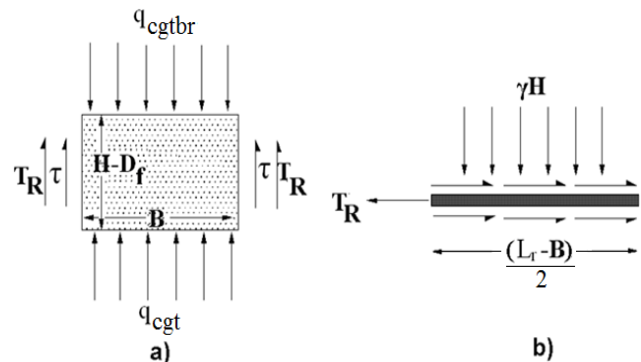

Fig. 4. Stresses on (a) reinforced granular column and (b) geosynthetic reinforcement.

Normalizing Eq. 14 with the undrained shear strength of compressible ground,  $s_u$ , the normalized ultimate bearing capacity,  $N_{cgtbr}$ , of a strip footing in a reinforced two-layered system of granular fill over compressible ground stabilized with granular trench is

$$N_{cgtbr} = \left[ \ln \left( \frac{G}{s_u} \right) + 1 \right] + 0.5 \left( \frac{\gamma_2 B}{s_u} \right) N_\gamma + \left( \frac{\gamma B}{s_u} \right) \times \left\{ \left[ \left( \frac{H}{B} \right)^2 - \left( \frac{D_f}{B} \right)^2 \right] K_s \tan \varphi + \left( \frac{D_f}{B} \right) N_q + \left( \frac{H}{B} \right) \tan \varphi_r \left( \frac{L_r}{B} - 1 \right) \right\} \quad (15)$$

### Transverse pull

According to Meyerhof's (1974) punching shear mode of failure for footings in two-layered soils, the column of granular material along with the footing moves down mobilizing shear resistance along its sides. Consequently, the geosynthetic reinforcement gets pushed down. The downward push causes the reinforcement to be pulled back transversally. Any transverse movement causes additional stresses to be mobilized underneath the reinforcement (Madhav and Umashankar, 2003). The additional stresses mobilized due to the transverse movement of the reinforcement are represented in Fig. 5.

A transverse displacement,  $\delta (=w_L)$ , of the reinforcement layer at the edge of the footing was considered by Madhav and Umashankar (2003) to estimate the additional resistance mobilized. A transverse resisting force,  $P$ , gets mobilized as a result of the transverse displacement,  $\delta$ , of the reinforcement. The pullout resistance of the reinforcement increases due to the transverse displacement. A set of equations formulated by Madhav and Umashankar (2003) (Eqs. 16 to 20) are used to estimate the resisting forces developed due to transverse displacement of the reinforcement. The tension developed in the reinforcement gets modified as

$$T_a = 2\gamma H \tan \varphi_r + P \tan \varphi_r \quad (16)$$

where  $P$  is the transverse force in the reinforcement developed due to the transverse component of displacement,  $\delta$ . The upward resisting force,  $P$ , is given by

$$P = \gamma H L_e P^* \quad (17)$$

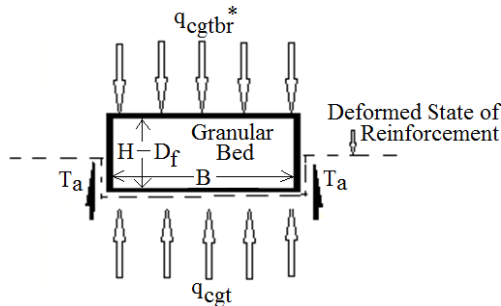

Fig. 5. Forces due to transverse displacement of reinforcement.

where  $L_e = (L_r - B)/2$  is the effective length of the reinforcement and  $P^*$  is the normalized transverse force in the reinforcement obtained from Madhav and Umashankar (2003) for a single inextensible sheet reinforcement of length,  $L_e$ , embedded at depth,  $H$ , in soil of unit weight,  $\gamma$ . The interface shear resistance between the reinforcement and the soil is characterized by the angle,  $\phi_r$  ( $\leq \phi$ , the angle of shearing resistance of the soil). In a soil with global relative stiffness,  $\mu$  ( $=k_s L_e / \gamma H$ ), the inextensible sheet reinforcement is subjected to transverse force,  $P$ , due to transverse displacement,  $w_L$ , in addition to the normal stresses acting on the top due to overburden pressure. The normalized tension,  $T_k^*$ , and normalized displacement,  $W_k$ , of the reinforcement are evaluated by Madhav and Umashankar (2003) as

$$T_{k+1}^* = T_k^* + \frac{1}{2n} \left( \mu \frac{w_L}{L_e} W_k + 2 \right) \quad (18)$$

$$W_k = \frac{T_k^* n^2 (W_{k+1} + W_{k-1})}{2n^2 T_k^* + \frac{\mu}{2 \tan \varphi_r}} \quad (19)$$

where  $k_s$  – the modulus of subgrade reaction of foundation soil;  $n$  – the number of elements the reinforcement is discretized for finite difference analysis;  $W$  ( $=w/w_L$ ) – the transverse displacement of reinforcement at any point normalized with  $w_L$  (the transverse displacement of reinforcement at free end);  $\mu$  – relative subgrade stiffness factor;  $T^*$  ( $=T/2\gamma H L_e \tan \varphi_r$ ) – the normalized tension developed in the reinforcement and  $T$  – the tension developed in the reinforcement. The normalized transverse force,  $P^*$ , is computed (Madhav and Umashankar, 2003) as

$$P^* = \frac{P}{\gamma H L_e} = \mu \frac{w_L}{L_e} \frac{1}{n} \left( \frac{W_1 + 1}{2} + \sum_{k=2}^n W_k \right) \quad (20)$$

The ultimate bearing capacity,  $q_{cgtbr}^*$ , of a strip footing in a two-layered system of reinforced granular fill over compressible ground stabilized with granular trench, considering kinematics, thus becomes

$$q_{cgtbr}^* = s_u \left[ \ln \left( \frac{G}{s_u} \right) + 1 \right] + 0.5 \gamma_2 B N_\gamma + \frac{\gamma (H^2 - D_f^2)}{B} K_s \tan \varphi + \gamma D_f N_q + \frac{\gamma H}{B} \tan \varphi_r (L_r - B) + \frac{\gamma H}{B} \tan \varphi_r (L_r - B) T^* + \frac{\gamma H}{B} (L_r - B) \frac{P^*}{2} \quad (21)$$

Normalizing Eq. 21 with the undrained shear strength of compressible ground,  $s_u$ , the normalized ultimate bearing capacity,  $N_{cgtbr}^*$ , of a strip footing in a reinforced two-layered system of granular fill over compressible ground stabilized with granular trench is



$$\begin{aligned}
N_{cgtbr}^* &= \left[ \ln \left( \frac{G}{s_u} \right) + 1 \right] + 0.5 \left( \frac{\gamma_2 B}{s_u} \right) N_\gamma \\
&+ \left( \frac{\gamma B}{s_u} \right) \left\{ \left[ \left( \frac{H}{B} \right)^2 - \left( \frac{D_f}{B} \right)^2 \right] K_s \tan \varphi + \left( \frac{D_f}{B} \right) N_q \right\} \\
&+ \left( \frac{\gamma B}{s_u} \right) \left( \frac{H}{B} \right) \left( \frac{L_r}{B} - 1 \right) \left[ \tan \varphi_r (1 + T^*) + \frac{P^*}{2} \right] \quad (22)
\end{aligned}$$

Bearing capacities ratios,  $BCR$ , are defined to quantify the degrees of improvement as:

$(BCR)_{cgtb} = N_{cgtb}/N_{cgt}$  is the ratio of the normalized ultimate bearing capacity of a strip footing in an unreinforced two-layered system of granular fill over compressible ground stabilized with granular trench to that in granular trench-reinforced ground alone. The ratio  $(BCR)_{cgtb}$  quantifies the contribution of the granular fill.

$(BCR)_{cgtbr} = N_{cgtbr}/N_{cgt}$  is the ratio of the normalized ultimate bearing capacity of a strip footing in a reinforced two-layered system of granular fill over compressible ground stabilized with granular trench to that in granular trench-reinforced ground alone. The ratio  $(BCR)_{cgtbr}$  quantifies the contributions of both the granular fill as well as the axial resistance mobilized by the geosynthetic reinforcement.

$(BCR)_{cgtbr}^* = N_{cgtbr}^*/N_{cgt}$  is the ratio of the normalized ultimate bearing capacity of a strip footing in a reinforced two-layered system of granular fill over compressible ground stabilized with granular trench to that in granular trench-reinforced ground alone. The ratio  $(BCR)_{cgtbr}^*$  quantifies the contributions of the granular fill and the axial + transverse resistances mobilized by the reinforcement.

#### 4 RESULTS AND DISCUSSION

The ultimate bearing capacity of a strip footing in a two-layered system of granular fill over soft compressible ground stabilized with granular trench, depends on the normalized foundation depth,  $D_f/B$ , angle of shearing resistance of the granular material,  $\varphi$ , normalized fill thickness,  $H/B$ ;  $G/s_u$ , related to the compressibility/stiffness of soft ground and  $\gamma B/s_u$ , related to the unit weight of the granular fill, width of the footing and undrained shear strength of soft ground. If the granular fill is reinforced with a layer of geosynthetic, parameters  $W_L$ ,  $\mu$ ,  $L_r/B$  and  $\varphi_r/\varphi$  also influence the bearing capacity of the footing. The values of the bearing capacity factors as given by Madhav and Vitkar (1978) are adopted for normalized trench width,  $B_r/B$  of 0.5 and  $c_1/c_2$  equal to 0. The granular fill, trench and soft ground are considered to have comparable unit weights while the trench and fill materials possess comparable angles of shearing resistance. A parametric study quantifies the effect of the parameters  $\gamma B/s_u$  and  $G/s_u$  on the normalized ultimate bearing capacity and  $BCR$  of the footing.

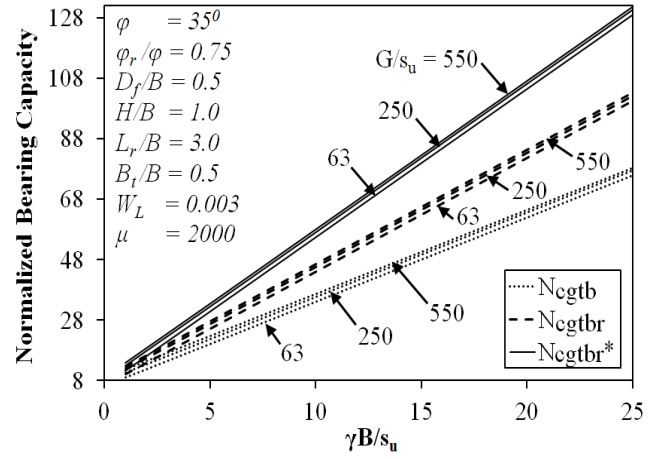

Fig. 6. Variation of normalized ultimate bearing capacity with  $\gamma B/s_u$  - effect of  $G/s_u$ .

$G/s_u$  of 63 corresponds to relatively soft ground with  $N_c$  of  $(2+\pi)$  while  $G/s_u$  of 550 represents stiffer material. This paper highlights the contribution of transverse resistance of reinforcement for typical normalized transverse displacement,  $W_L$ , of 0.003 and relative subgrade stiffness factor,  $\mu$ , of 2000. Figures 6 and 7 present the variations of the normalized bearing capacities,  $N_{cgtb}$ ,  $N_{cgtbr}$ ,  $N_{cgtbr}^*$  and bearing capacity ratios,  $(BCR)_{cgtb}$ ,  $(BCR)_{cgtbr}$ ,  $(BCR)_{cgtbr}^*$ , respectively, of a strip footing in a two-layered system of unreinforced and reinforced in granular fill over compressible ground stabilized with granular trench, with  $\gamma B/s_u$ , for  $\varphi$  of  $35^\circ$ ,  $D_f/B$  of 0.5,  $H/B$  of 1.0,  $\varphi_r/\varphi$  of 0.75,  $L_r/B$  of 3.0,  $B_r/B$  of 0.5,  $W_L$  of 0.003 and  $\mu$  of 2000, for  $G/s_u$  equal to 63, 250 and 550.  $N_{cgtb}$ ,  $N_{cgtbr}$ ,  $N_{cgtbr}^*$  increase linearly and  $(BCR)_{cgtb}$ ,  $(BCR)_{cgtbr}$ ,  $(BCR)_{cgtbr}^*$  non-linearly with  $\gamma B/s_u$  for different values of  $G/s_u$ . Strip footing in two-layered system of reinforced granular fill over compressible ground with granular trench projects higher normalized bearing capacity and  $BCR$  values when compared to an unreinforced granular bed. Relatively softer clays and wider footings with higher values of  $\gamma B/s_u$  display improved bearing capacity ratios.

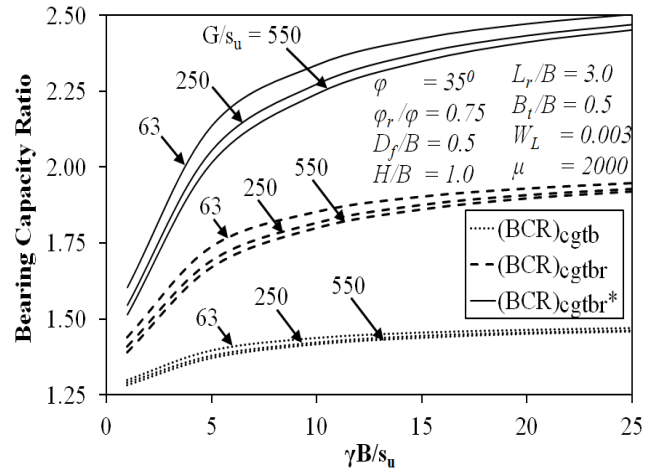

Fig. 7. Variation of bearing capacity ratio,  $BCR$ , with  $\gamma B/s_u$  - effect of  $G/s_u$ .

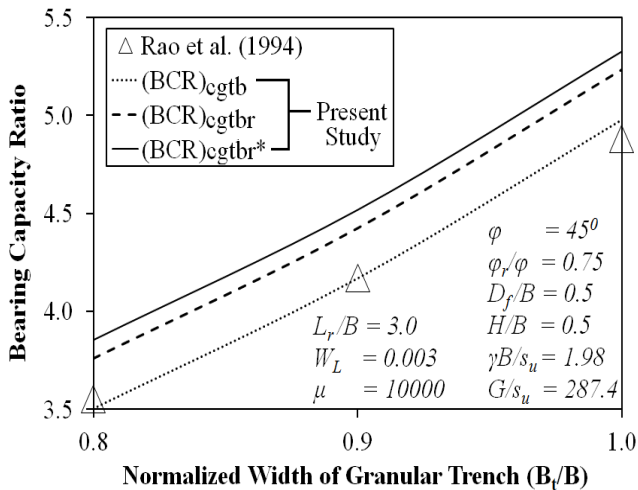

Fig. 8. Comparison of present study with experimental results of Rao *et al.* (1994).

Stiffness of ground increases with  $G/s_u$  and thus decreases relative improvement of bearing capacity of footing upon provision of *RFB*. Consideration of transverse resistance mobilized by reinforcement increases the bearing capacity of footing over and above the contribution of axial resistance.

Figure 8 compares the present method for estimation of bearing capacity of strip footing embedded in an unreinforced and reinforced granular fill over compressible ground stabilized with granular trench, with the experimental results of a strip footing in granular trench-stabilized weak clay, performed by Rao *et al.* (1994), for  $\phi$  of  $45^\circ$ ,  $\phi_r/\phi$  of 0.75,  $L_r/B$  of 3.0,  $D_f/B$  of 0.5,  $H/B$  of 0.5,  $\gamma B/s_u$  of 1.98,  $G/s_u$  of 287.4 and  $W_L$  of 0.003. Considering the granular material to be relatively dense (due to the high angle of shearing resistance of  $45^\circ$ ), the modulus of subgrade reaction,  $k_s$ , is considered to be  $90 \text{ MN/m}^3$  (Scott 1981). Hence, for  $k_s$  of  $90 \text{ MN/m}^3$ ,  $L_r/B$  of 3.0,  $\gamma B/s_u$  of 1.98 and  $H/B$  of 0.5, the relative subgrade stiffness factor,  $\mu$ , works out to be about 10000. Bearing capacity ratio plotted along ordinate (Fig. 8) is the ratio of the normalized ultimate bearing capacity of a strip footing in soft clay stabilized with granular trench to that in soft clay alone.  $(BCR)_{cgtb}$  of strip footing estimated from present study compares well with that obtained by Rao *et al.* (1994). Enhanced *BCR* values are projected in a reinforced case when compared to an unreinforced one. Consideration of transverse resistance of reinforcement to deformation together with axial resistance to pullout yields improved *BCR* over that considering axial resistance alone. *BCR* values increase with normalized width of granular trench due to larger volume of soft clay replaced by compacted granular material with relatively higher shear resistance.

## 5 CONCLUSIONS

A method for estimating the bearing capacity of a strip footing embedded in a geosynthetic reinforced granular bed over soft compressible ground stabilized with granular trench is presented. Consideration of compressibility/stiffness of soft ground yields relatively lower bearing capacity of footing but greater improvement upon provision of *RFB*, than otherwise. Relatively wider footings on dense granular fills over soft deposits display improved bearing capacity response. *BCR* of footing in two-layered system of reinforced granular fill over compressible ground stabilized with granular trench is greater than an unreinforced fill due to additional contributions from axial and transverse resistances mobilized by the reinforcement.

## REFERENCES

- 1) Abhishek, S.V., Rajyalakshmi, K. and Madhav, M.R. (2014): Bearing capacity of strip footing on reinforced foundation bed over soft ground with granular trench, *Indian Geotechnical Journal*, DOI 10.1007/s40098-014-0138-y.
- 2) Hamed, J.T. Das, B.M. and Echelberger, W.F. (1986): Bearing capacity of a strip foundation on granular trench in soft clay, *Civil Engineering for Practicing and Design Engineers*, 5(5), 359-376.
- 3) Madhav, M.R. and Umashankar, B. (2003): Analysis of inextensible sheet reinforcement subject to transverse displacement/force: linear subgrade response, *Geotextiles and Geomembranes*, 21, 69-84.
- 4) Madhav, M.R. and Vitkar, P.P. (1978): Strip footing on weak clay stabilized with granular trench or pile, *Canadian Geotechnical Journal*, 15, 605-609.
- 5) Meyerhof, G.G. (1974): Ultimate bearing capacity of footings on sand layer overlying clay, *Canadian Geotechnical Journal*, 11(2), 223-229.
- 6) Rao, G.V., Kate, J.M. and Shamsheer, F.H. (1994): Soil improvement with geosynthetics, *Proceedings of the 13<sup>th</sup> International Conference on Soil Mechanics and Foundation Engineering*, New Delhi, India, 1237-1240.
- 7) Scott, R.F. (1981): *Foundation Analysis*, Prentice-Hall Inc., Englewood Cliffs, NJ.
- 8) Unnikrishnan, N. and Rajan, S. (2012): Bearing capacity of strip footings on geosynthetic encapsulated granular trenches. *Proceedings of International Conference on Ground Improvement and Ground Control*, Wollongong, Australia, 977-983.
- 9) Vesic, A.S. (1972): Expansion of cavities in infinite soil mass, *Journal of Soil Mechanics and Foundations Division, ASCE*, 98(3), 265-290.